

A Review of Rammed Earth Construction

for

DTi Partners in Innovation Project
'Developing Rammed Earth for UK Housing'

May 2003

Prepared by:

Vasilios Maniatidis & Peter Walker

Natural Building Technology Group
Department of Architecture & Civil Engineering
University of Bath
Bath BA2 7AY
Telephone: 01225 386646
Facsimile: 01225 386691

Project Partners

- *University of Bath*
- *Insitu Rammed Earth*
- *Mark Lovell Design Engineers*
- *Engineers Haskins Robinson
Waters*
- *CADRE Architects*
- *Knauf Insulation*
- *Day Contracting*

Steering Group Members

- *Bristol City Council*
- *Building Research Establishment*
- *Ecology Building Society*
- *Feilden Clegg & Bradley Architects*
- *IHCM*
- *Grimshaw Architects*
- *Simmonds.Mills architect.builders*
- *Somerset Trust for Sustainable Development*

Acknowledgements

This review could not have been possible without the contribution from a number of individuals who allowed us to visit them in their homes and workplaces or gave up their time to be interviewed by phone. We are particularly grateful to Adele Mills, Andy Simmonds, Bill Swaney, Cindy Harris, Colin Williams, David Sheppard, Gordon Pearson, John Renwick, Jolyon Brewis, Kate Cheng, Marion & Francis Chalmers, Mark Lovell, Martin Waters, Mr & Mrs Adcock, Mr & Mrs Francis, Mr & Mrs Kinder, Mr F Westmoreland, Mr I West, Mr M H Roberts, Mrs S Cox, Mrs S Farley, Neal Barnes, Nigel Phillips, Pat Borer, Peter Clegg, Peter Trotman, Rowland Keable and Tim Hewitt.

We also gratefully acknowledge the support of the DTi, project partners and steering group members, without whose support this project would not have been possible.

Figures 5.4, 5.9 and 5.10 are reproduced from New Zealand Standard NZS 4299: “Earth Buildings not requiring specific design”, with kind permission from Standards New Zealand.

Figures 5.5, 5.6 and 5.7 are reproduced from “Adobe and Rammed Earth Buildings” by Paul McHenry, with kind permission from Carol McHenry and UA press.

Figures 3.7 and 5.8 are reproduced from Standards Association of Zimbabwe Standard SAZS 724:2001 “Rammed earth structures”, with kind permission from Standards Association of Zimbabwe.

Contents

Acknowledgments

1	Introduction	1
2	National Rammed Earth Codes	
2.1	Outline	2
2.2	Australia	2
2.3	Germany	3
2.4	New Zealand	3
2.5	Spain	4
2.6	USA (New Mexico)	5
2.7	Zimbabwe	5
2.8	Other countries	5
2.9	Summary	5
3	Materials in Rammed Earth Construction	
3.1	Outline	6
3.2	Soil Specification	6
3.2.1	Colour	6
3.2.2	Particle Size Distribution	7
3.2.2.1	Ideal Distribution	7
3.2.2.2	Test Procedures	7
3.2.2.3	Selection criteria for Natural Rammed Earth	8
3.2.2.4	Selection criteria for Cement Stabilized Rammed Earth	9
3.2.3	Plasticity	11
3.3	Properties of Natural Rammed Earth	12
3.3.1	Dry Density	12
3.3.2	Mechanical Strength	13
3.3.2.1	Compressive Strength	13
	(a) Field Tests	13
	(b) Laboratory Tests	14
	(c) Field Testing Walls	15
3.3.2.2	Tensile Strength	16
3.3.2.3	Bending Strength	16
3.3.2.4	Shear Strength	17
3.3.3	Durability	17
3.3.3.1	Rainfall erosion	17
3.3.3.2	Freeze-thaw erosion	18
3.3.4	Shrinkage	18
3.3.5	Surface Finish and Texture	19
3.3.6	Thermal Properties	19

3.4	Properties of Stabilised Rammed Earth	20
3.4.1	Stabilization	20
3.4.2	Cement Stabilization	20
	3.3.2.1 Cement Use	21
	3.3.2.2 Plasticity	21
	3.3.2.3 Compressive Strength	21
3.4.3	Lime Stabilization	21
3.4.4	Fibre Stabilization	22
3.4.5	Sodium Silicate Stabilization	22
3.5	Rammed Chalk	22
3.6	Conclusions	23

4 Structural Design

4.1	Structural Design of Earth Buildings	24
4.2	Structural Performance Requirements	25
4.2.1	Strength Design	25
	4.2.1.1 Compressive Strength Design	25
	4.2.1.2 Flexural Bending Strength	26
	4.2.1.3 Shear Strength	26
	4.2.1.4 Modulus of Elasticity	27
4.2.2	Serviceability Limit State	27
	4.2.2.1 Deflection	27
	(a) Minimum Wall Thickness	27
	(b) Maximum Wall Slenderness	28
	(c) Provisions for Openings	29
	4.2.2.2 Shrinkage	29
	4.2.2.3 Water Penetration & Frost Resistance	29
4.3	Structural Design of Rammed Earth	29
4.3.1	General Considerations – Type of elements	29
4.3.2	Combined Compression and Bending	30
4.3.3	Concentrated Compression Loads	30
4.3.4	Out-of-plane Flexural Capacity of Walls	31
	4.3.4.1 Out-of-plane horizontal bending	31
	4.3.4.2 Out of plane vertical bending	32
4.3.5	Design for Shear	32
	4.3.5.1 Shear Capacity	32
	4.3.5.2 Design of Shear Walls	33
4.3.6	Design for Torsion	33
4.4	Conclusions	33

5 Architectural Design & Detailing

5.1	Design	34
5.1.1	Outline	34
5.1.2	Site characteristics	34
	5.1.2.1 Local Climate	34
	5.1.2.2 Site Topography	34

5.1.2.3	Sunlight Direction	35
5.1.2.4	Wind	35
5.1.3	Architectural Plans	36
5.2	Details	38
5.2.1	Outline	38
5.2.2	Openings	38
5.2.2.1	Frame fixings	38
5.2.2.2	Lintels	40
5.2.3	Roof Support	42
5.2.3.1	Wall plates, Collar beams and Bond beams	42
5.2.3.2	Roof Fixings	42
5.2.4	Services	44
5.2.5	Non-structural wall fixings	45
5.3	Conclusions	45

6 Construction Methods

6.1	Soil Preparation	46
6.1.1	Outline	46
6.1.2	Excavation	46
6.1.3	Screening	46
6.1.4	Pulverization	47
6.1.5	Stockpiling	47
6.1.6	Mixing	47
6.2	Formwork	48
6.2.1	General Considerations	48
6.2.2	Traditional Formwork	49
6.2.3	Modern Formwork	50
6.2.3.1	Small-units Formwork	51
(a)	Horizontal Sliding Crawler Formwork	51
(b)	Vertically Sliding Formwork	51
6.2.3.2	Integral Formwork Systems	51
(a)	Australian Forming System	52
(b)	California Forming System	52
(c)	Continuous Wall System	52
6.2.3.3	Speciality Formwork	53
(a)	Corner Formwork	53
(b)	Curved Formwork	53
(c)	Formwork for Openings	53
(d)	Battered Formwork	54
(e)	Permanent Formwork	54
6.2.4	Organisation	54
6.3	Soil Compaction	55
6.3.1	Dynamic Compaction	55
6.3.1.1	Manual Compaction	55
6.3.1.2	Pneumatic Compaction	56
6.3.2	Vibrating Plate Compaction	57
6.3.3	Compactive effort	57
6.3.4	Horizontal Joints	57
6.4	Productivity	57

6.5	Conclusions	58
-----	-------------	----

7 Quality Control

7.1	Material Quality	59
7.1.1	Outline	59
7.1.2	Selection	59
7.1.3	Weather Conditions	59
7.1.4	Storage	60
7.1.5	Preparation	60
	7.1.5.1 Pulverisation	60
	7.1.5.2 Moisture Content	60
	7.1.5.3 Mixing	60
	7.1.5.4 Compaction	61
7.2	Construction Quality	
7.2.1	General Considerations	61
7.2.2	Construction Tolerances	61
7.2.3	Density	61
7.2.4	Compressive Strength	61
7.2.5	Erosion Resistance	62
7.2.6	Surface Defects	63
7.3	Conclusions	63

8 Foundations

8.1	Materials & Design	64
8.1.1	Outline	64
8.1.2	Foundation Types	64
8.1.3	Materials	64
8.1.4	Design	65
8.2	Details & Construction	67
8.2.1	Details	67
	8.2.1.1 Drainage	67
	8.2.1.2 Damp Proofing	67
8.2.2	Construction	68
8.3	Conclusions	68

9 Maintenance & Repairs

9.1	Maintenance	69
9.1.1	Outline	69
9.1.2	Maintenance Work	69
9.1.3	Design	71
9.2	Defects & Repairs	71
9.2.1	Defects	71
9.2.2	Repairs	72
	9.2.2.1 Repair of Surface Coatings	72

9.2.2.2	Repair of Structural Defects	72
(a)	Bulging	72
(b)	Shrinkage Cracking and Spalling	72
(c)	Structural Cracking and Underscour	73
9.2.3	Renovation of Old Earth Buildings	73
9.3	Conclusions	73

10 UK Rammed Earth Projects Review

10.1	Scope	74
10.2	Project Descriptions	74
10.2.1	Rammed Chalk Buildings, Hampshire	74
10.2.2	Amesbury Houses, Wiltshire	74
10.2.3	Holly Howe/Warburg Nature Reserve, Oxfordshire	75
10.2.4	Dragons Retreat, Devon	76
10.2.5	Visitors Centre, Eden Project, Cornwall	76
10.2.6	Woodley Park Centre for Sports & Arts, Lancashire	77
10.2.7	AtEIC Building/Centre for Alternative Technology, Powys	78
10.2.8	The Stables, Northamptonshire	79
10.2.9	Jasmine Cottage, Norfolk	79
10.2.10	Sutton Courtenay Environmental Education Centre, Oxfordshire	80
10.2.11	Sheepdrove Organic Farm, Berkshire	80
10.3	Summary of interviews	81
10.3.1	Codes of practice	81
10.3.2	Materials	81
10.3.3	Structural design	82
10.3.4	Architectural design & detailing	82
10.3.5	Construction	84
10.3.6	Quality Control	85
10.3.7	Foundations	85
10.3.8	Maintenance and Repair	86
10.3.9	Planning & Building Control	86
10.3.10	Financial aspects	86
10.3.11	Other observations	87

11 Conclusions

11.1	Final Conclusions	88
11.2	National Codes	88
11.3	Materials	88
11.4	Structural Design	88
11.5	Architectural Design & Detailing	89
11.6	Construction	89
11.7	Quality Control	89
11.8	Foundations	90
11.9	Maintenance & Repairs	90
11.10	Project Review Key Points	90

References	92
Bibliography	97
Useful Internet Addresses	109

List of Tables

Table 3.1:	Lower range limits for particle-size distribution of cob	14
Table 3.2:	Compressive strength test specimen details	15
Table 3.3:	Recommended design characteristic unconfined values for compressive strength	15
Table 3.4:	Maximum permissible linear shrinkage	19
Table 3.5:	Compressive strength for cement stabilized soils	21
Table 4.1:	Minimum Wall Thickness	27
Table 4.2:	Slenderness and eccentricity reduction factor K -	30
Table 5.1:	Timber lintels (Standards Australia, 2002)	41
Table 5.2:	Steel lintel sections (Standards Australia, 2002)	41
Table 6.1:	Manual Rammer Characteristics	56
Table 7.1:	Tolerances in earth construction	62
Table 8.1:	Geometrical Properties of reinforced concrete spread footing	65
Table 9.1:	Maintenance of earth buildings (Standard Australia, 2002)	70

List of Figures

Fig. 3.1:	Chelsea Flower show exhibit wall	6
Fig. 3.2:	Lower range limits for particle-size distribution for natural rammed earth	8
Fig. 3.3:	Upper range limits for particle size distribution for natural rammed earth	9
Fig. 3.4:	Grading limits for cement stabilization	10
Fig. 3.5:	Lower range limits for particle-size distribution for cement stabilization	10
Fig. 3.6:	Upper range limits for particle-size distribution for cement stabilization	11
Fig. 3.7:	Indirect compressive strength test	16
Fig. 5.1:	Plan of No. 124 Holders Road, Amesbury	37
Fig. 5.2:	Plan of No. 67 Holders Road, Amesbury	37
Fig. 5.3:	Plan of No. 28 Holders Road, Amesbury, prior to demolition	37
Fig. 5.4:	Anchor for doors and windows	39
Fig. 5.5:	Details of window jambs (top) and heads (bottom)	39
Fig. 5.6:	Details of door jamb sections	39
Fig. 5.7:	Details of door head sections	40
Fig. 5.8:	Fixings	43
Fig. 5.9:	Timber bond beam-roof connection	43

Fig. 5.10:	Reinforced concrete bond beam-roof connection	44
Fig. 6.1:	Modern concrete shuttering for rammed earth	50
Fig. 6.2:	Modern Australian Formwork (Bill Swaney)	52
Fig. 6.3:	Battered formwork at Eden Project	54
Fig. 6.4:	Pneumatic rammer	56
Fig. 10.1:	Five storey rammed chalk building in Winchester, Hampshire	74
Fig. 10.2:	Residential rammed chalk property in Amesbury, Wiltshire	75
Fig. 10.3:	Fruit/vegetable store in Warburg Nature Reserve, Oxfordshire	75
Fig. 10.4:	Dragons Retreat, Plymouth, Devon	76
Fig. 10.5:	Visitors Centre, Eden Project, Cornwall	77
Fig. 10.6:	Woodley Park Centre for Sports & Arts, Lancashire	77
Fig. 10.7:	AtEIC Building/Centre for Alternative Technology, Machynlleth, Powys	78
Fig. 10.8:	The Stables/The Manor, Northamptonshire	79
Fig. 10.9:	Jasmine Cottage, Norfolk	79
Fig. 10.10:	Sutton Courtenay Environmental Education Centre, Oxfordshire	80
Fig. 10.11:	Sheepdrove Organic Farm, Berkshire	80

1.0 Introduction

Rammed earth walls are formed by compacting damp soil between temporary forms. Together with other forms of unbaked earthen construction, such as mud-brick, rammed earth has a long and continued history throughout many regions of the world. Major centres of rammed earth construction include North Africa, Australasia, regions of North and South America, China and Europe, including France, Germany and Spain. Rammed earth or pisé construction has been practised in the UK for well over 200 years. Throughout the nineteenth century a significant number of rammed earth and rammed chalk buildings were built in Wessex. Following WWI a series of experimental rammed earth and chalk houses were built in Amesbury, Wiltshire. However, it is the revival over the past 10 or so years that has led to this review of rammed earth construction, undertaken as part of the DTi Partners in Innovation project 'Developing rammed earth construction for UK housing'. The project seeks to promote the use of rammed earth construction in the UK through the publication and dissemination of a set of design and construction guidance notes.

The review comprises a study of the current state of the art of rammed earth construction as published in over 200 books, journal and conference papers, scientific reports and other articles. In addition to the literature review recent and historic rammed earth projects in the UK have also been studied and these findings are presented as well. This combined literature and project review forms an important contribution to the process of writing the guidance notes.

The review of current literature is presented in eight separate chapters; each considering different aspects of rammed earth construction. Chapter 2 provides a brief overview of current national reference documents and codes for rammed earth from around the world. The use of appropriate soil is key to the success of rammed earth. Chapter 3 summarises the characteristics of soils considered important and outlines the test methods and typical physical properties of rammed earth. Basic structural design procedures and architectural design and details for rammed earth are presented in chapters 4 and 5 respectively. The basic components of rammed earth construction and methods used for compaction are considered in chapter 6. Quality control issues, including defects and tolerances for construction, are summarised in the following chapter. Chapter 8 outlines typical foundation details used for rammed earth. The literature review concludes with a summary of maintenance and repair practices.

In collaboration with the literature study the review also investigated various aspects of recent and historic rammed earth buildings in the UK. All recent and significant rammed earth buildings, including Eden Project Visitors Centre and Centre for Alternative Technology, together with a number of important historic examples, including the Amesbury houses, were visited. A wide range of people associated with these projects, including architects, structural engineers, clients, owners, contractors, conservationists and building control officers, were interviewed to establish current UK practice in rammed earth construction. Brief details of each building studied are provided and results of the interviews are presented. In conclusion chapter 11 summarises the findings of this review of literature and UK practice. A rammed earth bibliography including over 200 publications and some web site addresses is also presented.

National Rammed Earth Codes 2

2.1 Outline

As part of the review national standards and reference documents for earthen construction, and some more specifically for rammed earth, from six countries are examined in some detail. Five of these national reference documents, two from Australia, New Zealand, USA (New Mexico), and Zimbabwe are written in English. A further two from Germany and Spain have been reviewed following partial translation. A brief overview of the content, development and status of each of these documents are briefly presented below. However, it is not intended here to provide a detailed review of each of these documents; this is done separately in each relevant section of the review. Provisions set out in the Australian, New Zealand and New Mexican codes often reflect the common use of cement stabilisation in these countries.

2.2 Australia

Australia was one the earliest countries to develop a national design and construction reference document for adobe, pressed block and rammed earth building. Bulletin 5 (Middleton, 1952) was first published in 1952 by the then Commonwealth Experimental Building Station. This was followed three subsequent updated editions in 1976, 1981 and most recently the fourth edition in 1987, published by CSIRO. Bulletin 5 sets out the 'requirements and capabilities' of rammed earth construction, as well as adobe and pressed block. Material performance requirements specified by Bulletin 5 include the accelerated spray erosion test. Some provisions of Bulletin 5, including structural values for earth-wall design, are referenced in the Building Code of Australia.

In recognition that modern earth building practice had somewhat superseded much of the advice provided in Bulletin 5, the Earth Building Association of Australia, in partnership with the Earth Building Association of New Zealand, led work on developing joint Standards Australia/Standards New Zealand documents for earthen construction. Work commenced in 1994 by committee BD-083. However, following failure to reach a consensus on many issues work on the joint standard documents for Australia and New Zealand ceased in 1996. Standards New Zealand went on to publish three standards in 1998 (see below), whereas Standards Australia elected, in light of the lack of consensus, to publish a handbook document. Standards Australia handbooks, often prepared by an individual author, do not carry the same status as full standards, prepared by technical committee, but seek to provide state-of-the-art advice and guidance.

The Australian Earth Building Handbook was published by Standards Australia in August 2002 (Standards Australia, 2002). The handbook sets out the principles of accepted good practice and recommended design guidelines for lightly loaded, primarily single and two storey buildings, constructed using stabilised and unstabilised unbaked earthen walls and floors. Although this is still an advisory document, it takes the process towards standardisation a step further towards a full Standard.

The Australian Earth Building Handbook consists of six main chapters. Chapter one gives a brief history of earthen construction with reference to the merits and disadvantages of the methods and forms of construction used. The second chapter details the materials and techniques available for earthen construction, while chapter three incorporates advice on the detailing, construction and maintenance of earth

National Rammed Earth Codes 2

structures. The following chapter sets out the performance requirements of earth walls with regards to durability and structural integrity and provides guidelines for the effective design of reinforced and unreinforced earth walls. Chapter five details the design of footings for earth buildings whilst the last chapter addresses areas for further development of earth buildings such as quality control, education and training, and mechanisation. In the Appendices included, detailed information about material testing is given.

In 2001 the Earth Building Association of Australia published a draft document outlining the organisation's proposed alternative design guidelines for adobe and rammed earth construction (Earth Building Association of Australia, 2001). The proposed draft guidelines include guidance on appropriate materials and methods for evaluation. Design guidance for rammed earth includes footings, damp proof courses, openings, wall slenderness limits, lintels, joints, and recommended details for connections. To date the document remains a draft proposal.

2.3 Germany

West Germany was one of the first countries in the world to draw up standards for earthen construction. Documents covering earthen construction, including rammed earth, were published between 1947 and 1956 (Houben & Guillaud, 1994). However, these standards were withdrawn in 1970.

The Lehmbau Regeln was published in 1999. Though lacking the status of a national DIN standard the Lehmbau Regeln provide a national reference document that has subsequently been referenced in the building control regulations of some regional governments. Chapter one sets out the general requirements of earthen construction, while chapter two specifies the types of suitable soil for earth construction and the appropriate selection tests. The third chapter concentrates on describing the various earth wall construction methods (including rammed earth, cob and light straw clay) and materials for the specific application, while the next chapter details the design procedures for each of these methods. In addition, details of the design of vaults, non load-bearing walls, ceiling joists and rendering are also provided. Chapter five presents some earth properties such as density, thermal insulation, permeability and sound absorption. Chapter six touches upon contractual issues whilst the last chapter presents a glossary of the terms used either within the document or more broadly in earthen construction.

2.4 New Zealand

In New Zealand the design of unfired earthen wall building materials (adobe, pressed brick, poured earth and rammed earth), with or without chemical stabilisation, is governed by three separate codes published in 1998 by Standards New Zealand:

- NZS 4297:1998, New Zealand Standard. *Engineering Design of Earth Buildings*. Standard New Zealand, Wellington, New Zealand;
- NZS 4298:1998, New Zealand Standard. *Materials and Workmanship for Earth Buildings*. Standard New Zealand, Wellington, New Zealand; and

National Rammed Earth Codes 2

- NZS 4299:1998, New Zealand Standard. *Earth Buildings Not Requiring Specific Design*. Standard New Zealand, Wellington, New Zealand.

These standards were prepared together by technical committee, with significant input from members of the Earth Building Association of New Zealand. The New Zealand Standards have a legal status and should be followed by parties involved in the design of earth buildings.

NZS 4297:1998 sets out structural design methods for earth walls up to a maximum height of 6.5m (irrespective of thickness). For taller walls more specialised structural engineering advice should be sought. The standard sets the performance criteria for durability, strength, shrinkage and thermal and fire insulation of earth elements. Guidance is provided with regards to ultimate limit and serviceability state design for flexure, with or without axial load, and shear. Finally reinforcement and anchorage details are provided along with details on the requirements for the design of the foundation.

NZS 4299:1998 is limited to earth walls with maximum height of 3.3m or less depending on earthquake zone factor. Buildings designed using this standard should have ground floor plan not exceeding 600m² for single storey buildings or 300m² per floor for 2 storey buildings. The maximum floor live load should not exceed 1.5kN/m² with some further minor restrictions regarding the building layout and the foundations also apply. The standard provides standard solutions for the design of walls, structural diaphragms, footings, bond beams and lintels, control joints and openings and fixings. However if any of the conditions stated above is not fulfilled the design should be carried out in accordance with NZS 4297:1998.

NZS 4298:1998 applies to both NZS 4297:1998 and NZS 4299:1998 and sets the requirements for the materials and workmanship when designing earthen elements with soil/cement mixtures less than 15% by weight. The standard provides the general requirements with regards to materials selection and testing, reinforcement and bracing details, control joints, surface finish and quality control. Furthermore, additional requirements relating to the methods of construction (namely rammed earth, adobe bricks, pressed bricks, CINVA bricks and poured earth) are presented.

2.5 Spain

In 1992, the Ministry of Transportation and Public Works of Spain published a guidance document for the design and construction of earthen structures (Ministerio de Obras Públicas y Transportes, 1992). The document has five main sections and the main focus is on rammed earth, although references and comparisons with adobe techniques are given.

The first section of the document is a general historical account of rammed earth and adobe. Section two details the design principles for earth walls, mainly for compression, tension and buckling. The third section examines the construction methods for rammed earth. The formwork used is detailed, the ramming methods demonstrated and the ideal construction sequence is explained. Finally, the construction of earth wall footings and corners is elaborated. The last section provides guidance on quality control measures in order to ensure compliance of the constructed earth walls with the design specifications.

National Rammed Earth Codes 2

The guidance involves information on material testing, additives, reinforcement, formwork and general construction tolerances.

2.6 USA (New Mexico)

The US State of New Mexico has its own building code for adobe and rammed earth (New Mexico Building Code, 1991). The building code provides some very limited guidance on soil suitability and moisture content, and sets out requirements for formwork, methods of construction, testing and curing of rammed earth. The code should be read in conjunction with all other applicable building standards such as the Uniform Building Code.

2.7 Zimbabwe

The Zimbabwe Standard Code of Practice for Rammed Earth Structures was published in 2001 (SAZS 724:2001). The document bases much of its content on the Code of Practice for Rammed Earth Structures published by Julian Keable (1996). Prepared by technical committee the standard however includes additional material, including reference to the accelerated spray erosion test presented in Bulletin 5 (Middleton, 1987) and NZS 4298 (1998).

The standard consists of six sections plus appendices. The first section details materials specifications, section two the formwork requirements, and section three the provisions regarding the design of footings for earth buildings. The fourth section details the design of the superstructure with the main focus on the compressive strength, water absorption and weather erosion of the earthen walls, including details for visual inspection. The fifth section concentrates on the structural stability of the walls whilst the final section gives guidance on the detailing and finishes of the earthen elements. Finally, the Appendices include detailed information on material testing.

2.8 Other countries

At various times a number of other countries that have produced codes or national reference documents for earthen construction. According to Houben & Guillaud (1994) these include France, India, Tanzania, Mozambique, Morocco, Tunisia, Kenya, Ivory Coast, Mexico, Brazil, Peru, Turkey and Costa Rica. Many of these documents do not cover rammed earth, whilst others have been withdrawn and obtaining copies has, unfortunately, not been possible. In recent times CRATerre has led development of regional standards for pressed earth block construction.

2.9 Summary

To date no national standard or reference document has been published for rammed earth construction in the UK. Over the past fifty years a number of standards and national reference documents have been published in Australia, Germany, New Zealand, Spain, USA and Zimbabwe. Perhaps not surprisingly many of these countries have led the modern revival of rammed earth construction. Whilst the building culture and climate of these countries may differ from conditions in the UK, the combined experience outlined in these national documents expresses the current state-of-the-art in rammed earth construction around the world, and will therefore form an important basis for the development of the UK guidelines.

Materials in Rammed Earth Construction 3

3.1 Outline

This chapter presents an overview of the material characteristics and soil selection procedures for rammed earth structures, as proposed by various researchers and earth practitioners from around the world.

The chapter is divided into three main sections. The first presents general properties of the materials used for rammed earth. The second focuses on the physical properties of natural rammed earth. Finally section three details the properties of rammed earth with various additive materials.

Soil stabilization comprises a variety, and often combination, of modification processes to improve soil properties, including strength and resistance to water. In addition to compaction, an inherent element of rammed earth construction that seeks to maximise material density, stabilizing additives can be combined with the natural soil. Additives generally fall into two classes: those that materially increase strength and reduce moisture absorption; and to those that reduce moisture absorption and moisture movement but do not appreciably increase strength (Middleton, 1952). Additives commonly used in rammed earth are briefly considered in this review.

3.2 Soil Specification

3.2.1 Colour

Natural soil is available in a very wide range of colours, including reds, yellows, browns, greys, greens, blues, white, and black. Red colour soils are often preferred. Variation in aggregate colour can lead to non-uniform finishes. Though other parameters, such as strength and erosion resistance, are more likely to govern soil selection, colour is an important aesthetic consideration for the client and designer. Natural colours can be varied by using additives, such as lime and cement, or by blending different soils. The use of varying coloured soils has been used very effectively by a number of builders, including Clark (figure 3.1) and Rauch (Kapfinger, 2001), to enhance the stratified (layered) finish. Use of some surface treatments, such as sodium silicate and PVA, can alter the surface colour, and should generally be checked before main application.

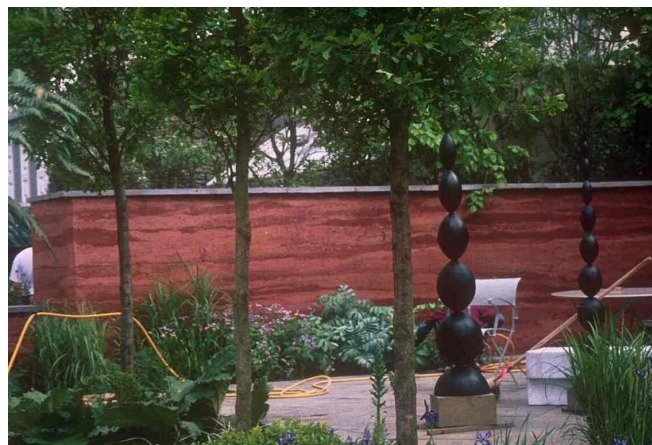

Figure 3.1: Chelsea Flower show exhibit wall, built by David Clark in 2000 (photo by: David Clark)

Materials in Rammed Earth Construction **3**

3.2.2 Particle Size Distribution

Particle size distribution testing by sieving and sedimentation testing has become acceptable practice for appraisal of soil for rammed earth. However, influence of variation in grading on physical characteristics of rammed earth, including both strength and durability, remains unclear (Keable, 1994). Organic matter content should be avoided, as this may lead to high shrinkage and possible biodeterioration as well as increasing susceptibility to insect attack. Organic material also interferes with action of stabilizers such as cement.

3.2.2.1 Ideal Distribution

In order to increase the mechanical strength and weathering resistance of soil it is advantageous to minimise the voids ratio in order to increase the contact between soil particles. Theoretically soils with no voids can be achieved if the soil particles are entirely spherical and their distribution follows the Fuller Formula below:

$$p = 100(d/D)^n$$

where: p is the proportion of grains of a given diameter
d is the diameter of grains for a given value of p
D is the largest grain diameter
n is the grading coefficient

When the grains are entirely spherical then n is equal to 0.5. However, in earth construction a value of n between 0.20 and 0.25 is more appropriate depending on grain shape (Houben & Guillaud, 1994). In reality it is virtually impossible to find natural soils that match such an ideal distribution.

Engineering soils may be classified based on the relative size proportion of their main elements, namely gravel, sand, silt and clay. The British Standard grading limits used in this report are:

- Gravel, 60 mm to 2 mm
- Sand, 2.00mm to 0.06mm
- Silt, 0.06mm to 0.002mm
- Clay, less than 0.002mm

More generally care is required when reviewing international literature as particle size definition limits do vary (ACI Materials Journal, 1990; Alley, 1948; Jaggard, 1921; Middleton, 1995).

3.2.2.2 Test Procedures

The jar test is a field-test used to establish approximate (volume) proportions of the main soil constituents. In preparation the jar is quarter filled with the test soil and then filled with water and shaken vigorously. The jar is then left to stand for an hour and then is shaken again. The different soil elements precipitate at different rates and therefore after around eight hours (Standards Australia, 2002) the depth of each distinctive layer can be measured. The test can provide a crude approximation of grading but its reliability is questionable with significant errors reported (Keable, 1994).

Materials in Rammed Earth Construction 3

The more generally accepted laboratory tests used to obtain the particle size distribution of a soil sample follow the procedures set out in BS 1377, Part 2 (1990) for civil engineering classification. The procedure comprises wet sieving, dry sieving and sedimentation or pipette method to establish fines grading.

3.2.2.3 Selection criteria for Natural Rammed Earth

A wide variety of sub-soils have been used for natural rammed earth buildings, with the exception of uniform coarse sands and gravels with no fines or cementing agents (Hughes, 1983). For earth wall construction, the soil should contain all four elements (McHenry, 1984). Ideally the soil should have a high sand/gravel content, with some silt and just enough clay to act as a binder and assist soil compaction (Keable, 1996). According to Norton (1997) any material coarser than 5-10mm should be sieved out. Previous experimental work indicates that increasing gravel size reduces the compressive strength of rammed earth cylinders (Patty & Minium). However more research is warranted to define grading for rammed earth, especially maximum gravel size and proportions. Proposals tend to converge towards a 30%-70% balance between clay/silt and sand proportions (Berglund, 1986; Dayton, 1991; Easton, 1996).

Nevertheless no soil is likely to be ideal with regards to all of the aspects considered (Saxton, 1995) and therefore researchers around the world usually publish upper and lower limits for each of the main soil elements. Figure 3.2 shows the lower and Figure 3.3 the upper range limits for clay, silt, sand and gravel for rammed earth construction, as proposed by various researchers. In general the percentages are 'by mass', though in some cases (McHenry, 1986) it is not clear whether the percentages stated by the author were 'by volume' or 'by mass'.

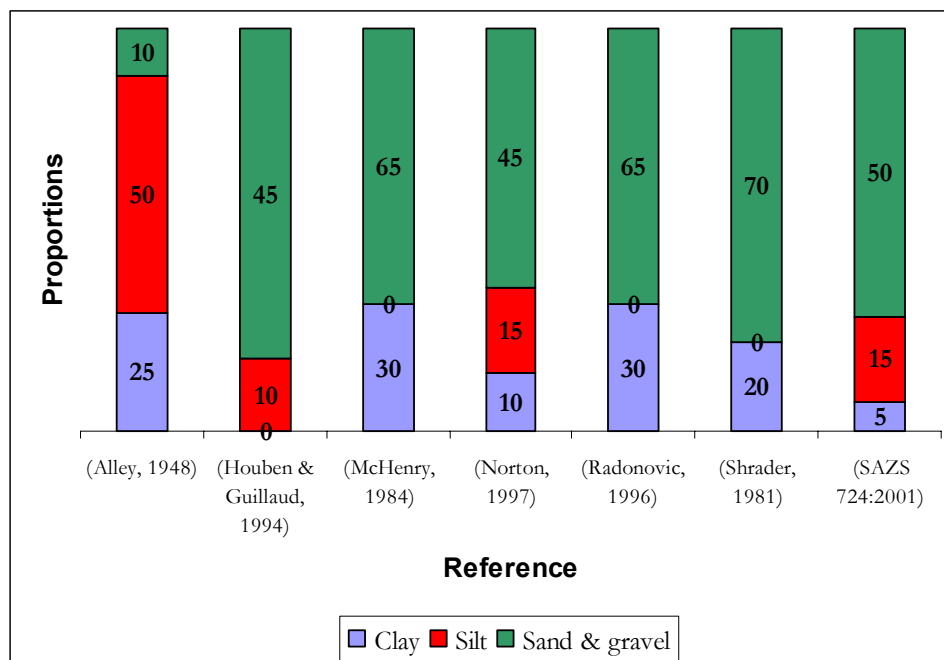

Figure 3.2: Lower range limits for particle size distribution for natural rammed earth.

Materials in Rammed Earth Construction 3

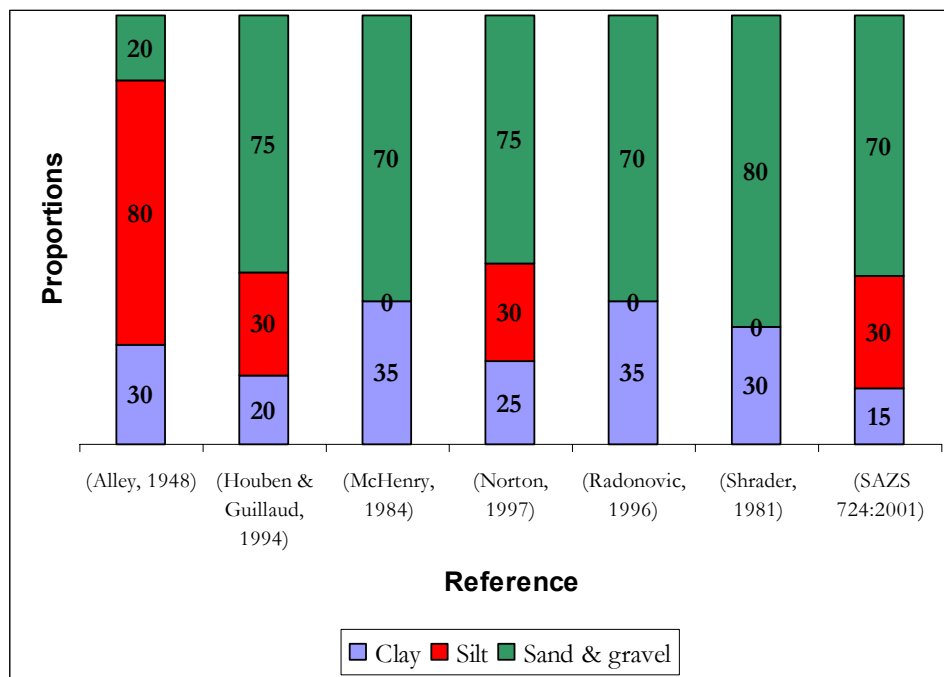

Figure 3.3: Upper range limits for particle size distribution for natural rammed earth

From the above it is clear that in broad terms there is some agreement on the limits between the main soil elements. The minimum percentage of combined clay and silt should be between 20%-25% while the maximum between 30%-35%. Similarly, the minimum percentage of sand should be between 50%-55% while the maximum is between 70%-75%. Some anomalies can be explained on the basis of different limits for the soil constituents, as stated previously (Alley, 1948). Based on various experimental data, CRATerre-EAG (Houben & Guillaud, 1994) has produced a graph including grading curve limits for rammed earth construction. The graph is in agreement with the limits stated previously and can readily display when correction of grain size distribution may be required (Standards Australia, 2002).

3.2.2.4 *Selection criteria for Cement Stabilized Rammed Earth*

Soils for cement stabilized rammed earth tend to have proportionally higher sand and gravel content and correspondingly lower fines content. Figure 3.4 shows the recommended composition of soil cement as proposed by various authors.

Materials in Rammed Earth Construction 3

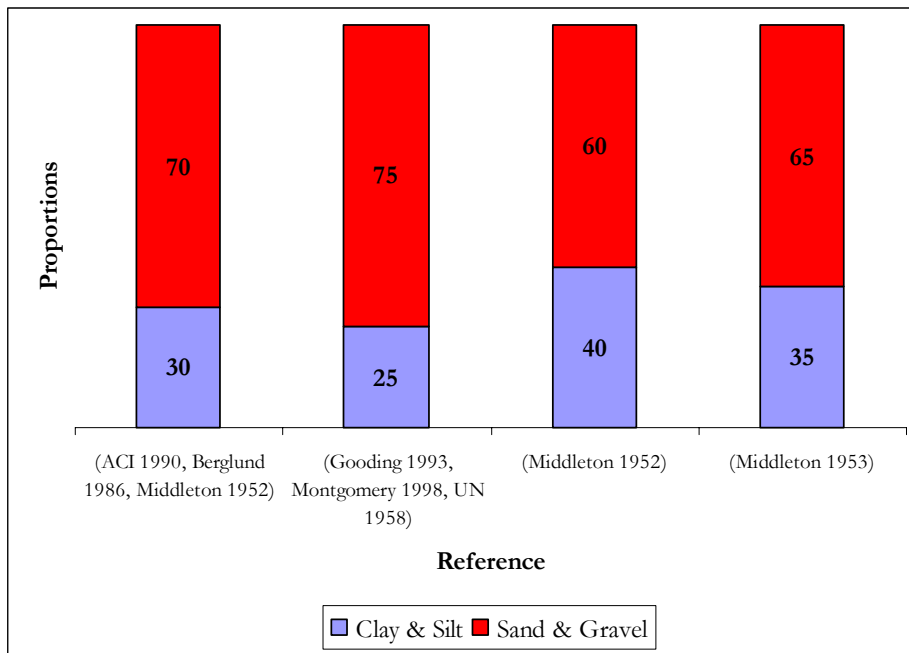

Figure 3.4: Grading proportions for cement stabilization

Figures 3.5 and 3.6 on the other hand present the lower and upper limits for each of the main soil elements for cement stabilized rammed earth.

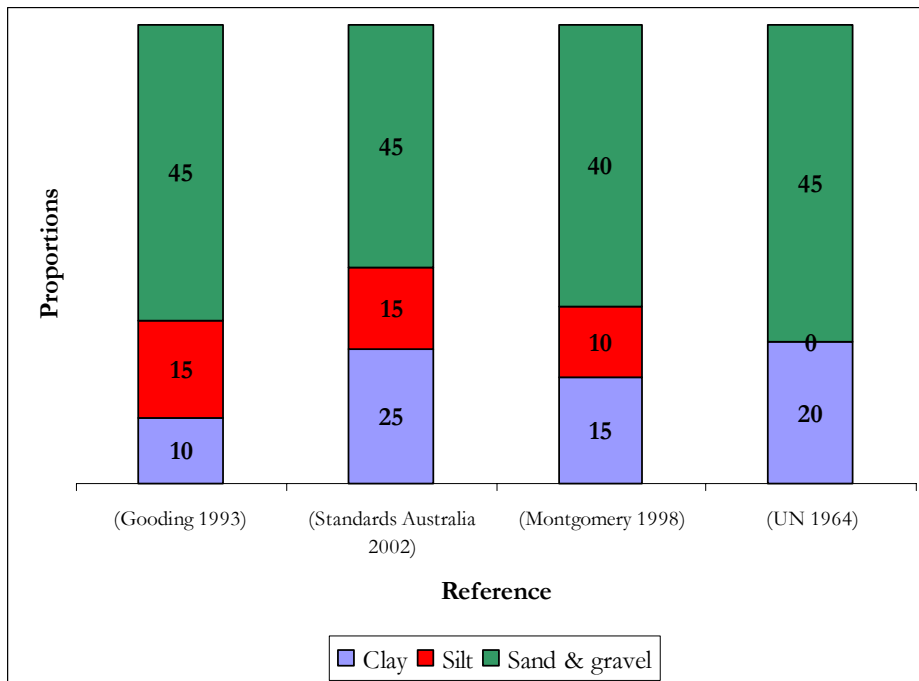

Figure 3.5: Lower range limits for particle-size distribution for cement stabilization

Materials in Rammed Earth Construction 3

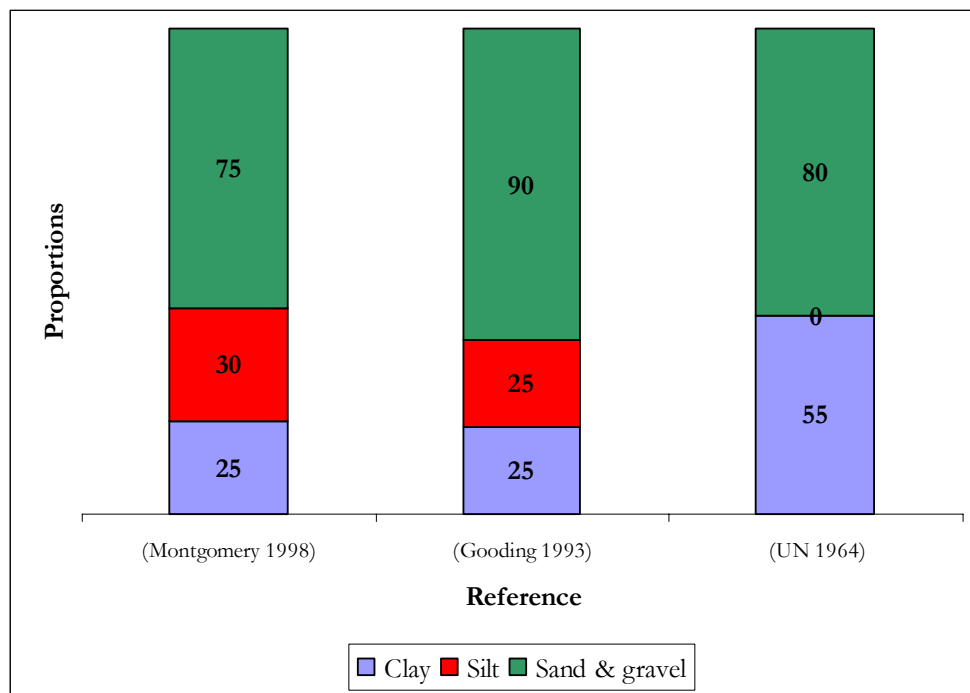

Figure 3.6: Upper range limits for particle-size distribution for cement stabilization

In broad terms the criteria presented are in agreement. For example, a soil suitable for cement stabilization should have a significant sand content, at least greater than 50% and preferably closer to 75%, and at the same time low clay content, typically less than 25%. As in the case of unstabilized rammed earth, these criteria are intended as a broad initial guide for soil selection and include recommendations for soil blocks as well as rammed earth.

3.2.3 Plasticity

Soil plasticity, the ability of a soil to undergo irreversible deformation while still resisting an increase in loading, is indicated by the plasticity index. The plasticity index is the water content increase (% of dry weight) required for a soil to pass from a plastic to a liquid state. Experimentally the plasticity index can be found by estimating the plastic and limits.

A standard method for measuring plastic limit is described in BS 1377-2, 1990. Soil is screened through a 425 μ m sieve and dried. On re-wetting soil is rolled out by hand on a flat surface, usually glass. The plastic limit is defined as the moisture content at which the soil can no longer be rolled to 3mm diameter thread without breaking.

The most common method for obtaining the liquid limit is the cone penetrometer method. A standard 30° angle cone is brought into contact with the soil surface that has been previously mixed with water. The cone is released and the penetration under gravity at the end of 5 sec is recorded. This process is repeated for increasing soil moisture content until a semilog curve of moisture content versus penetration may be produced. From the graph the moisture content corresponding to 20mm penetration is recorded. This value is the liquid limit.

Materials in Rammed Earth Construction **3**

According to Houben & Guillaud (1994) liquid limit for unstabilized soils should be between 25% and 50% (30%-35% preferred) and the plastic limit between 10% and 25% (12%-22% preferred). Plasticity index is the numerical difference between liquid and plastic limits. The plasticity index is an indication of the clay content and characteristics of the soil. The higher plasticity index is indicative of higher clay content and/or active clay mineral and that higher shrinkage will occur when the earth dries.

For rammed earth, Alley (1948) proposed a Plasticity Index as low as 6%, however more recent research allows for higher values. Based on various experimental data, mainly for stabilized applications, CRA Terre-EAG (Houben & Guillaud 1994) has produced a plasticity chart.

3.3 Properties of Natural Rammed Earth

3.3.1 Dry Density

The dry density of soil in rammed earth applications is dependant on soil type, the moisture content during compaction and compactive effort. Knowledge of the dry density of rammed earth is important during design to calculate loads on structural elements. A broad range of dry density values are quoted for rammed earth, varying from 1700 kg/m³ to 2200 kg/m³ (Adam, 1995; Standards Australia, 2002; Houben & Guillaud, 1994).

In order to achieve maximum density, it is important that the optimum moisture content, appropriate to method of compaction, is used when ramming. Both the 'standard' and 'modified' Proctor tests are routinely used to determine optimum moisture content and maximum dry density of soils for rammed earth (BS 1377-4, 1990). A soil sample of known moisture content is compacted in a 1 litre cylindrical mould. Compaction is carried out in 3 or 5 layers of equal thickness by a dropping weight falling 27 times on each layer from 300mm or 450mm. When the cylinder is ready, the wet weight is recorded and then the sample is left to dry. At least 5 specimens at various moisture contents are prepared the same way and their wet weights are recorded. When the samples dry, the moisture content and dry densities are calculated and plotted on a graph. From the resultant curve, it is possible to determine the optimum moisture content for which the soil experiences its maximum dry density for a given compactive effort. Values of dry density and optimum moisture content for a given soil are dependent on compactive effort. Comparisons between the compactive effort of Proctor tests and actual construction practice are difficult. Accurate estimates of compaction are problematic due to variations in practice. In Australia modified Proctor is considered more appropriate. Another study suggests that compactive effort of standard Proctor is too low, as result optimum moisture content is too high for pneumatic placement (Keable, 1994).

A good first approximation of the optimum moisture content can be achieved using the 'drop test'. A ball of moist soil, approximately 40 mm diameter, is compacted by hand. When prepared the soil ball is dropped onto a hard flat surface from a height of approximately 1.5m. When the soil is too dry the ball breaks into many pieces. When enough water has been added so that the ball breaks into only a few pieces, the soil is

Materials in Rammed Earth Construction 3

very close to its optimum moisture content. If the ball remains in one piece then the soil is too wet. The test is a reliable means of controlling soil moisture content during construction. For rammed earth, the soil is normally quite dry compared with other earthen techniques such as cob and adobe.

3.3.2 Mechanical Strength

Rammed earth, as any other form of earth construction, has relatively good strength in compression but generally poor strength in shear and tension, especially when moist.

3.3.2.1 Compressive Strength

The mechanical strength of a soil is very much dependent on the voids ratio of the soil after ramming, cohesive strength of fines content, aggregate strength and moisture condition during testing. Density of the soil is a very important factor for the strength of the soil. Therefore, in the same way that it is difficult to give a specific value for the density, it is impossible to predict an exact value for the mechanical strength of a soil based on any kind of description with no prior testing.

(a) Field Tests

A simple field test to evaluate the compressive capacity of a soil is the so-called thread test. A lump of earth about the size of an olive, wet enough to be easily rolled, is placed onto a clean flat surface. Using the palm and finger, pressure is exerted on the soil to roll it into a thread of equal diameter. If the thread breaks before the diameter is reduced to about 3mm then more water is required. When a 3mm thread is achieved the sample is rolled until it starts crumbling. Then a ball is formed and squeezed between the fingers. If the thread is tough and requires a lot of effort to squeeze, the soil has a lot of clay and should not be used due to potential shrinkage problems. A medium strength thread indicates adequate amount of clay and the soil may be suitable for natural rammed earth while a very weak thread is an indication of a lot of sand and silt and very little clay, soils unsuitable for natural rammed earth construction.

Another simple field test used to determine the suitability of soil for rammed earth construction is the ribbon test. A sample large enough to form a roll in the size of a cigar is threaded and if it breaks before the diameter is reduced to 3mm more water is added. When the water content is right, the roll is flattened by squeezing between the thumb and forefinger to form a ribbon 150-200mm long and 2mm-6mm thick. The ribbon is then carefully handled to form the maximum length of ribbon that the soil will support. A long ribbon is indicative of too much clay. A short ribbon on the other hand, indicates low clay content and hence a soil likely to have insufficient strength. Interpretations of the ribbon test as proposed by various authors are presented in Table 3.1.

Materials in Rammed Earth Construction 3

Table 3.1: Ribbon test evaluation

Soil Classification	Ribbon Length (mm)				
	Easton, 1996	Standards Australia, 2002	Houben & Guillaud, 1994	Keable, 1996	Norton, 1997
Soil, unsuitable due to excessive shrinkage	>200	>80	250-300	>120	>150
Low-strength soil	<100	<40	50-100	<80	<80

From the values in Table 3.1 it is clear that the results obtained using the ribbon test can be ambiguous. The test procedure has been found to be user dependent and varies according to experience. Minke (2000) claims that this test can produce errors of more than 200%. Therefore field tests for the estimation of soil compressive strength can only be used as guidance in the early stages of the selection procedure. During the design stage, more accurate laboratory tests should be performed.

(b) Laboratory Tests

The laboratory tests used for determining the compressive strength of rammed earth are similar to the ones used for concrete, bricks and blocks (United Nations, 1958). A summary of the required specimen details for compression strength testing according to various standards around the world is presented in Table 3.2.

The specimens can be either cylinders or prisms (including cubes) prepared with a specified density/compaction effort. Specimens are capped using hardboard, plaster or similar material. A concentric load is applied continuously until failure occurs and the maximum load is recorded. During testing measurements of axial strain allow the modulus of elasticity and stress-strain relationship to be determined.

The compressive strength is usually expressed in terms of the characteristic value and a height/width correction factor may be applied (Middleton, 1992; Standards Australia, 2002; NZS 4298:1998, 1998). The recommended design values for rammed earth as proposed the above codes are summarized in Table 3.3.

Materials in Rammed Earth Construction **3**

Table 3.2: Compressive strength test specimen details

Reference	Specimen details					
	Cylinder		Prism			Minimum number of specimens required
	diameter (mm)	height (mm)	height (mm)	length (mm)	width (mm)	
Bulletin 5; Earth-Wall Construction, CSIRO	150	110	150	150	1.3 x h	5
Standards Australia, 2002	150	300	N/A	N/A	N/A	1 sample for every 25-100m ²
New Mexico Adobe & Rammed Earth Building Code (Tibbets, 2001)	N/A	N/A	102 (4'')	102 (4'')	102 (4'')	N/S
NZS	N/A	N/A	N/S	N/S	2 x h	5

Table 3.3: Recommended design values for characteristic unconfined compressive strength

Reference	Characteristic unconfined compressive Strength
Bulletin 5; (Middleton, 1992)	0.7 N/mm ²
Standards Australia, 2002	0.4 - 0.6 N/mm ²
NZS 4298:1998, 1998	0.5 N/mm ²

In the case of the New Mexico Code (Tibbets, 2001) it is not clear whether the proposed values are the characteristic or average value; the minimum required value of compressive strength for rammed earth is 300psi (2.07 N/mm²). Some previous studies have reported increase in compressive strength of natural rammed earth specimens with time (Patty, 1936; Keable, 1994). However, processes that cause this, other than reduction in moisture content, are unclear and require further investigation.

(c) *Field Testing Walls*

The Zimbabwe Standard Code of Practice for Rammed Earth Structures (SAZS 724:2001, 2001) requires at least 1.5 N/mm² compressive strength for one storey walls of up to 400mm thick and 2.0 N/mm² for two storey walls. However the procedure for obtaining the strength is based on interpretation of indirect surface hardness testing of the built wall. The test utilises a spring capable of applying the required stress to a

Materials in Rammed Earth Construction 3

rammed earth surface (Figure 3.7). The apparatus is placed firmly against the wall and the tester is firmly pushed towards the wall until the flat pressure disk is touching the sample face. The tester is then removed, the procedure is repeated ten times and if the sample is unmarked at least eight times out of ten, the sample is considered in compliance with the code.

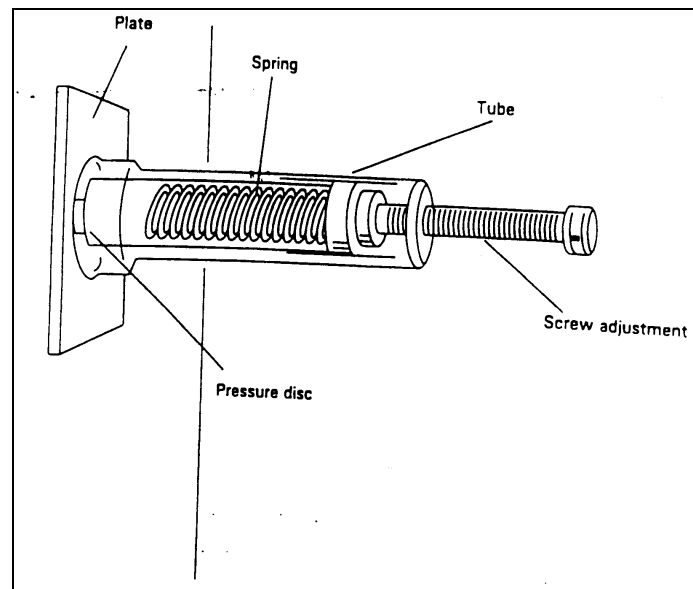

Figure 3.7: Indirect compressive strength test
(Reproduced from SAZS 724:2001 Rammed Earth Structures)

3.3.2.2 Tensile Strength

As stated previously, rammed earth is very weak in tension. Rammed earth elements should therefore not be designed for pure tension. If required, comparative testing procedures are detailed by the Road Research Laboratory for cement stabilized rammed earth (Bofinger, 1970).

3.3.2.3 Bending Strength

In the absence of direct experimental data, the design characteristic bending strength of rammed earth should normally be taken as zero (Standards Australia, 2002). However in cases where design relies on bending resistance from the wall elements, a direct bending strength test should be performed with a block or panel of earth supported at each end on a bar and a load applied either through a third bar in the mid-span or uniformly across the clear span (Standards Australia, 2002; Houben & Guillaud, 1994; NZS 4298:1998, 1998).

Materials in Rammed Earth Construction **3**

3.3.2.4 Shear Strength

In the absence of direct experimental data, the design characteristic shear strength of natural rammed earth should normally be taken as zero (Standards Australia, 2002). However, shear may be assumed to be carried by frictional resistance.

3.3.3 Durability

Durability in the context of earth construction means the ability of the structure and all its elements to withstand the destructive action of weathering and other actions without degradation to the expected service life. Rain and frost are the most destructive natural actions causing erosion and deterioration of the earthen elements. Accidental abrasion is also a significant agent of deterioration. Some previous studies have noted relationship between compressive strength or durability and accelerated durability test performance (Walker, 2000; Shihata & Baghdadi, 2001; Keable 1994).

3.3.3.1 Rainfall erosion

The performance of natural rammed earth under driving rain cannot be readily predicted in the absence of test data. However, at the same time there is little correlative data between laboratory tests and field erosion. Building element erosion is complicated by various parameters, such as exposure, shelter and maintenance. Two main test procedures have been developed to measure the relative erosion resistance of earth elements, namely water drip tests and spray tests. A third test procedure, based on repeated wetting and drying cycles (ASTM D559, 1989), is widely used for cement stabilised materials but is not generally suitable for natural earth and thus has not been included in this review. A variety of different drip and spray test procedures have been proposed; two of the more widely used for natural rammed earth are outlined here. There is little or no correlative data between accelerated test performance and actual building performance of materials. Consequently, pass/fail test criteria are somewhat arbitrary.

The Geelong drip test is a simple assessment test in which water droplets are allowed to impact onto the surface of the test specimen. Initially developed for adobe mud blocks the test can be adopted for rammed earth as well, using specimens 300 x 300 x 125mm thick. Each specimen is inclined at 27° from the horizontal and water is released through a 16mm wide sponge cloth and allowed to fall 400mm in droplets. One hundred millilitres of water should be released within 20 to 60 minutes of the test commencing and the sample performance is measured in terms of pitting depth and depth of moisture penetration. According to New Zealand Standard (NZS 4298:1998, 1998), Standards Association of Zimbabwe (SAZS 724:2001, 2001) and Standards Australia (2002) failure of the specimen occurs when the pitting depth is greater than 15mm or the depth of moisture penetration is greater than 120mm.

The spray test has been developed by CSIRO in Australia (Middleton, 1992) but has been more widely accepted. The specimens are subject to a continuous jet of water spray at 50kPa pressure for 60min or until a specimen has completely eroded through, whichever occurs first. The 50mm spray nozzle is 470mm away from the sample and the

Materials in Rammed Earth Construction 3

exposed soil area is bound by an impermeable shield, leaving uncovered a circular section of either 150mm or 70mm diameter. The water spray is temporarily stopped every 15min to allow measurements of the depth of erosion with a 10mm diameter flat-ended rod. The maximum depth is taken as the rate of erosion for the whole specimen. According to New Zealand Standard (NZS 4298:1998, 1998) and Standards Association of Zimbabwe (SAZS 724:2001, 2001) failure of the specimen occurs when the depth of erosion or the depth of moisture penetration is greater than 120mm.

3.3.3.2 Freeze-thaw deterioration

As in the case of erosion due to driving rain, the ability of rammed earth to retain integrity when exposed to freezing temperatures cannot be readily predicted. The main test procedure used to assess freeze-thaw durability of rammed earth has been developed by ASTM (ASTM D560, 1989) for soil-cement. The test requires subjecting rammed earth samples to 12 cycles of freezing and thawing whilst the specimens remain saturated. After thawing specimens are subjected to abrasion by a wire brush to remove loosened material. The percentage of mass loss at the end of the test is calculated and if the weight losses are less than the values indicated by the standard used the specimen is considered adequate to produce a durable rammed earth wall. Suitability criteria exist only for soil-cement typically vary between 5 and 14%. (ACI Materials Journal Report, 1990). Shihata et al (2001) proposed another method of freeze/thaw testing for soil cement that claims to be simplified.

To date there is no recognised procedure for freeze thaw testing of natural rammed earth materials. Problems achieving and maintaining sufficiently high moisture content for freeze-thaw action to occur remains to be resolved. Indeed this test problem suggests that freeze-thaw may not be significant problem in light of the general requirement to maintain low moisture content in walls. Freeze-thaw problems are likely to be most significant immediately following construction, when material may be considered green and at a uniformly high moisture content.

3.3.4 Shrinkage

Rammed earth, as all earth building materials containing clay, swell on contact with water and shrink on drying. In both cases failure might occur and hence swelling/shrinkage control is vital. The extent of these phenomena is very much dependent on clay present (type, amount), soil grading and moisture content changes. Only experimental data can confidently predict the percentage of shrinkage expected for a particular soil.

There are a large number of shrinkage-type tests reported. The most widely used test utilizes a mould of internal dimensions of 600 x 40 x 40mm, or 600 x 50 x 50mm in the case of New Zealand Standard (NZS 4298:1998, 1998). Particles larger than 6mm are removed and water is added to the soil until the sample reaches its Liquid Limit. The mould is filled with the soil and attention is taken so that no air is trapped. The soil is left to dry and total shrinkage is measured. The maximum permissible linear shrinkage according to various codes and researchers is shown on Table 3.4. However linear shrinkage testing is not suitable for predicting the level of shrinkage in a rammed earth specimen, as the method of placement and initial moisture content differ significantly.

Materials in Rammed Earth Construction 3

Table 3.4: Maximum permissible linear shrinkage

Reference	Maximum permissible linear shrinkage
Standards Australia, 2002	<2.5%
Keable J., 1996	2%
NZS 4298:1998, 1998	0.05%
Scottish Executive, 2001	3%

The New Mexico Adobe & Rammed Earth Building Code (Tibbets, 2001) adopts a different approach to the problem of shrinkage and requires the preparation of four inch (102mm) cube samples which following drying should not contain more than three shrinkage cracks and no shrinkage crack should exceed two inches (51mm) in length or one-eighth of an inch (≈ 3 mm) width. Regardless of any code requirements, the shrinkage characteristics of a soil should be examined and incorporated into the design to satisfy the serviceability requirement of the structure under consideration.

3.3.5 Surface Finish and Texture

The surface finish of rammed earth is a function of many variables. Although it is difficult to describe the ideal finish in terms of dimensional accuracy some standards provide partial guidance. For example according to Standards Australia (2002) the shrinkage cracks should be no more than 3mm wide, while according to the Standards Association of Zimbabwe (SAZS 724:2001, 2001) the shrinkage cracks should not be longer than 75mm and should be limited to twenty in any square metre. In fact the Standards Association of Zimbabwe (SAZS 724:2001, 2001) gives some practical advice to avoid usual problems associated with finishes. For example in order to avoid honeycombing or boniness it is advisable not to use oversized gravel next to the formwork and to thoroughly mix the soil prior to placing it in the moulds. Shrinkage cracks can be limited if the drying out of the wall is carefully controlled, the clay content of the soil reduced and movement joints introduced. However it is difficult to numerically pre-specify the wall finish and therefore the visible surface standard of a completed wall should ideally be measured against that of an agreed sample wall or referenced finish (Standards Australia, 2002).

3.3.6 Thermal Properties

The thermal performance of rammed earth is measured in a number of different ways. The most commonly used properties are:

- *Thermal Storage*- This is a measure of the specific heat capacity expressed in volume terms and has units of $J/m^3^{\circ}C$. Houben & Guillaud (1994) claims that for rammed earth the thermal storage is around $1830 J/m^3^{\circ}C$.
- *Thermal Resistance (R-value)*- This is a measure of the opposition to heat transfer offered by a building element of specified thickness and is measured in m^2K/W . According to Standards Australia (2002), a 300mm thick rammed earth wall has an R-value between 0.35-0.70 m^2K/W .

Materials in Rammed Earth Construction 3

- *Thermal Transmittance (U-values)*- This is a measure of the overall rate of heat transfer, by all mechanisms under standard conditions, through a particular section of construction and is measured in W/m^2K . Minke (2000) claims that the U-values for a 300mm thick rammed earth can be as much as 1.9-2.0 W/m^2K .

Rammed earth, as a dense material, has poor insulating properties.

3.4 Properties of Stabilised Rammed Earth

3.4.1 Stabilization

The use of stabilizers such as cement has derived out of a need to improve wet strength and erosion resistance in very exposed walls (Houben & Guillaud, 1994). However, in Australia and USA, cement stabilisation has become accepted routine practice in rammed earth construction irrespective of application. In many situations the use of cement and other stabilizers can be avoided by good design and construction appropriate to earth building.

To optimise the benefits of stabilization then soils should meet a number of requirements. Soil should be free of humus and plant matter, though under certain conditions, plant matter like straw can be added, provided it is dry, with no danger of later deterioration (Minke, 2000). In addition soil should mainly consist of sand and fine gravel, with only sufficient clay for any required cohesive strength and a proportion of silt to act as void filler.

The main categories of binders used for earth construction are (Standards Australia, 2002; Houben & Guillaud 1994; SAZS 724:2001, 2001) Portland cement, lime, bitumen, natural fibre and chemical solutions such as silicates.

3.4.2 Cement Stabilization

There various advantages when using cement as a stabilizer. Soil samples gain strength from both the formation of a cement gel matrix that binds together the soil particles and the bonding of the surface-active particles, like clay, within the soil (Crowley, 1997). High levels of cement stabilisation improve the surface coating and reduce erosion (Walker, 2000) while increasing the cement has a considerable influence in improving the resistance of soils vulnerable to frost attack (Bryan, 1988).

However there are notable disadvantages using cement. The permeability of most soils is reduced (ACI Materials Journal Committee, 1990) and hence the natural ability of earth to allow passage of moisture throughout the soil mass is also significantly impaired. Environmental impact of cement production and reduced ability for recycling of rammed earth are also significant arguments against widespread use of cement in rammed earth construction. Less significantly, thermal conductivity, compared to lime stabilized blocks, is reportedly increased (Adam, 1995).

Materials in Rammed Earth Construction **3**

3.4.2.1 Cement use

Cement is typically used in proportions between 4% and 15%, with between 6% and 10% the most commonly specified. Increased cement content improves strength and erosion resistance. The amount of cement required will depend on grading and other soil characteristics. Presence of clay generally impedes effectiveness of cement stabilisation and, therefore should be generally minimised.

3.4.2.2 Plasticity

According to Gooding (1993), a soil suitable for cement stabilization should have a low plasticity index. However plasticity index ranges proposed by Standard Australia (2002) and the United Nations (1958) provide a very wide range, from around 2% to almost 30%. Similarly for rammed earth the range proposed by Standard Australia (2002) is from 15% to 30%.

3.4.2.3 Compressive Strength

As stated previously the presence of cement increases the strength of soil. Hence the values proposed by different authors, as presented in Table 3.5, tend to be much higher than the ones proposed for unstabilized soils.

Table 3.5: Compressive Strength for Cement Stabilized Soils

Compressive Strength (N/mm ²)			
	ACI Materials Journal Committee, 1990	Standards Australia, 2002	Houben & Guillaud, 1994
Sandy and gravely soils	2.76-6.89	-	-
Silty soils	2.07-6.21	-	-
Clayey soils	1.72-4.14	-	-
Cement Stabilized Rammed Earth	-	1-15	2-5

However, as in the case of unstabilized soils the range is large and therefore the values can only be used as a broad estimate of expectations. Experimental testing is essential in order to establish design values for a particular application.

3.4.3 Lime Stabilization

Though there are few reported examples of lime stabilized rammed earth walls, lime is included here as potential for future consideration. Much of the data below relates to use of lime in compressed earth block production. Unlike cement, which works with the coarse particles of a soil, non-hydraulic lime works with the clay minerals in a soil. Tests have indicated that there is an optimum lime dosage for a soil beyond which compressive strength decreases (Norton, 1997). The likely dosages are between 6-12% lime by dry

Materials in Rammed Earth Construction 3

weight and will increase as clay content increases (Houben & Guillaud, 1994; Montgomery, 1998; Norton, 1997).

According to Houben & Guillaud (1994), soils stabilized with lime have a bulk density around 2200kg/m^3 . Standard Australia (2002) states that the ideal soil for lime stabilisation should have a plasticity index between 20% and 30% with the liquid limit from 25 to 50. Therefore lime stabilization is ideally suited for stabilization of expansive soils (Venkatarama & Lokras, 1998). Lime achieves its final strength more slowly than cement (Norton, 1997) and therefore the curing period should be at least three times more than the one used for cement (normally 28 days). However, hardening rate has been increased using steam curing (Venkatarama & Lokras, 1998), though there is limited potential for rammed earth.

3.4.4 Fibre Stabilization

Fibres are used to improve the thermal performance and bending and tensile strength of soil. Natural fibres used include straw, sisal fibres and timber. According to Standards Australia (2002), the ideal soil for fibre stabilisation should have a plasticity index between 15% and 35% with the liquid limit from 30% to 50%.

One disadvantage of fibre stabilization is that the compressive strength of soils decreases as the straw content increases (Minke, 2000).

3.4.5 Sodium Silicate Stabilization

Sodium silicate is used at quantities of around 5% to act as a binding agent to increase compressive strength in sandy and silty soils. According to Houben & Guillaud (1994), a curing period of about 7 days is advisable.

3.5 Rammed Chalk

Rammed chalk is a particular type of rammed earth construction found in some regions of Britain, such as Wessex, where suitable deposits of chalk are readily available. Though the method of construction differs little from rammed earth, walls are formed from chalk rubble rather than clay bearing sub soil. The excavated chalk is broken down into fragments preferably no larger than 50-75 mm before ramming. Most rammed chalk buildings were built using pure chalk rubble, rather than a clay chalk blend such as used for Wychert in Buckinghamshire. A large number of rammed chalk buildings were built in Winchester around 1840 when chalk rubble spoil from railway cuttings was used (Pearson, 1992).

Chalk is a sedimentary rock of between 70 and 100 million years old. It was formed from the remains of tiny shellfish (foraminifera) cemented together by lime secretions of algae (coccoliths). Chalk has quite distinct characteristics from the clay bearing sub soils used for natural rammed earth. Typically the plasticity index is much lower; with plastic and liquid limits of chalk around 21% and 27% respectively. The density of rammed chalk is much lower than natural chalk, varying between 1300 and 1720kg/m^3 . Though there is little published information, rammed chalk wall compressive strengths are generally considered to be in excess of 0.5N/mm^2 (Pearson, 1992).

Materials in Rammed Earth Construction 3

3.6 **Conclusions**

Although unsuitable soils can be readily identified, standard soil characterisation tests, such as grading, are not reliable to establish the suitability of a soil for rammed earth. Further testing for mechanical strength and weathering resistance should be conducted prior to any soil selection. Broadly speaking, unsuitable soils for earthen construction include:

- Clays, fat clays, organic silts, organic silty clays, organic clays, clean gravel;
- Those soils containing organic matter of a type prone to rot or breakdown with the wall;
- Those soils which contain water-soluble salts to an extent which will impair the strength or durability of the wall;
- Those containing aggregate large enough to impair the strength or homogeneous performance of the wall, though such soils may be suitable if screened; and
- Soils that dry with surface containing many fine cracks, though such soils can be made to work by using surface treatments, plasters or screening.

In summary soils suitable for rammed earth houses are broad and include sands with sufficient clay and silt, clayey silts, clayey gravels and gravel-sand-clay mixtures.

Though soil suitability guidance is helpful it is also very general and therefore vague. In specific projects soil suitability must be assessed by treating physical parameters (shrinkage, strength, erosion resistance) of individual soil samples. Test performance criteria should be agreed and specified at the design stage.

4.1 Outline

Load bearing earth buildings have of course developed over millennia completely in the absence of structural design standards or codes. Rules of thumb for geometric wall proportions developed through the experience of trial and error have proven sufficient to enable earth building to achieve at least 10 stories high. The majority of earthen buildings are low rise, single or two storey, and consequently the stresses experienced by the thick earth walls are generally well within the modest capabilities of the material.

As building regulations, design codes and national building standards have developed over the past 100 or so years then inevitably building standards have also developed to cover earthen buildings. In Germany DIN Standards relating to earth building were developed following World War II, though were subsequently withdrawn in 1970. In Australia the first edition of Bulletin 5, a national reference document for earth building, was published by CSIRO in 1952 (Middleton, 1992).

The development of structural design codes for earthen buildings have largely followed similar proposals developed for masonry construction in Australia, New Zealand, Spain and USA (Standards Australia, 2002; Middleton, 1992; NZS 4297:1998, 1998; MOPT, 1992). Reasons for this are perhaps two-fold. Masonry and earth are both comparatively strong in compression and relatively weak and brittle in tension and consequently are both suited to load bearing and non-load bearing wall construction in low and medium rise buildings. In addition, the important earth building techniques of adobe and compressed earth block may be considered as forms of masonry construction. However, despite obvious differences in construction proposed structural design guides for both rammed earth and cob have both also adopted or adapted methodologies developed for masonry construction. The validity of this assumption has however rarely been tested by experimental data.

Limited reported tests on strength properties of rammed earth have generally centred on properties of small cylindrical specimens rather than behaviour of large or full-scale walls. Kornouchow (1933) reported in 1933 on tests undertaken in Ukraine on strength and stability of eccentrically loaded rammed earth walls. Obtaining a copy of this report has not been possible, unfortunately, to date. However, in 1995 Lilley and Robinson (1995) reported on the ultimate strength testing of rammed earth walls built with natural tropical lateritic soils. The walls contained a variety of window openings of differing configurations, including a semi-circular arch, pointed arch and flat lintel. Though tests confirmed suitability of forming openings by blocking out with different shapes, experimental data are unfortunately of limited use in development of more generalised guidelines for compression behaviour of rammed earth walls. Roach (1994) conducted a study to compare strength of cylindrical specimens of cement stabilised rammed earth with that of small walls. Compressive strength of the walls, around 2 N/mm^2 , was found to be similar to that predicted by 150 mm diameter cylinders. Other tests have been undertaken at the University of Western Australia on flexural behaviour of reinforced cement stabilized rammed earth (Radanovic, 1996; Deeks, 1998).

In many low rise situations rigorous structural design of walls is not necessary and wall proportions will follow 'rule of thumb' guidelines for maximum slenderness such as proposed by Earth Building Association of Australia (2001) and/or be governed by other

considerations such as thermal performance or durability. However, as rammed earth building becomes more widely accepted and used more innovatively the need for rational structural design guidelines becomes more important.

Permissible stress design recommendations for earth walls, including rammed earth, have been proposed by McHenry (1984), Middleton (1992), MOPT (1992), Houben & Guillaud (1994), King (1996) and the German Lehm- und Ziegelbau Regeln (1999). Limit state design approaches for rammed earth have more recently been adopted in New Zealand (NZS 4297:1998, 1998) and Australia (Standards Australia, 2002). Though not always explicitly written for structural rammed earth, the Australian (Middleton, 1992; Standards Australia 2002), New Zealand (NZS 4297:1998, 1998) and USA (McHenry, 1984; King, 1996) design guides were developed in countries where cement stabilisation in rammed earth is common place. All these published structural design documents are reviewed below.

4.2 Structural Performance Requirements

4.2.1 Strength Design

In keeping with structural masonry design the primary ultimate limit states for rammed earth walls are compression failure, including buckling, lateral bending failure, and shear failure. Current limit state philosophy codes (NZS 4297:1998 1998; Standards Australia, 2002) use 95% characteristic material strengths (f_k) based on either rather limited published data or experimental test results. Given the very limited data recommended design values for characteristic design strengths are generally believed to be conservative. For example in absence of experimental data flexural tensile and shear strengths are often assumed to be zero.

4.2.1.1 Compressive Strength Design

Wherever possible the characteristic compressive strength of rammed earth (f_c) should be established by experimental testing using methods such as those outlined in the chapter 3 of this report. Testing of cylinders will provide a characteristic unconfined material compressive strength (f_{uc}). The design compressive strength is given by:

$$f_c = \phi \times f_{uc} \quad (4.1)$$

where ϕ is the capacity reduction factor (also known as the partial safety factor for materials) applied to the experimental characteristic value.

In the New Zealand Standard for engineering design of earth buildings (NZS 4297:1998, 1998) the capacity reduction factor for axial compression and bearing is taken as 0.60, whilst the Australian earth building handbook (Standards Australia, 2002) takes a factor between 0.4 and 0.45.

In the absence of experimental data the Australian earth building handbook (Standards Australia, 2002) suggests values for design compressive strength between 0.40 N/mm² and 0.60 N/mm². The New Zealand Standard for engineering design of earth buildings (NZS 4297:1998, 1998) uses a design compressive strength equal to 0.5 N/mm².

In Bulletin 5 (Middleton, 1992), a safe working, rather ultimate limit state, compressive stress of 0.25 N/mm^2 for stabilized rammed earth is recommended; however, the value should also reflect the importance of the structure and the expected variations of the construction quality. King (1996) proposes an allowable compressive stress in stabilized rammed earth walls equal to 20% of material compressive strength.

4.2.1.2 Flexural Bending Strength

As in the case of compressive strength, characteristic bending strength of rammed earth (f_t) should be established by experiment. To establish design bending strength a capacity reduction factor between 0.60 and 0.80 is adopted by the Australian (Standards Australia, 2002) and New Zealand (NZS 4297:1998, 1998) design documents.

If no experimental results are available, but testing for compressive strength has been carried out, the New Zealand Standard (NZS 4297:1998, 1998) proposes taking the characteristic bending strength as equal to 10% of the characteristic compressive strength, for materials with compressive strength less than 6 N/mm^2 . As general guidance with no available test results the New Zealand standard proposes taking a value of characteristic bending strength equal to 0.1 N/mm^2 . More conservatively the Australian earth building handbook recommends ignoring any material strength in bending in the absence of test data (Standards Australia, 2002).

For permissible stress design King (1996) proposes taking an allowable flexural compressive stress in a stabilized rammed earth wall equal to 45% of the material compressive strength, whilst Easton (1996) suggests a value of 33% of the compressive strength for stabilised rammed earth.

4.2.1.3 Shear Strength

When experimental data are available, the characteristic basic shear strength of rammed earth (f_v) should be equal to the product of the capacity reduction factor times the unconfined shear strength of the material. The recommended capacity reduction factors for shear should be either 0.70 (NZS 4297:1998, 1998) or not greater than 0.60 (Standards Australia, 2002).

If experimental data for compressive strength are available then according to the New Zealand Standard (NZS 4297:1998, 1998) the shear strength of rammed earth can be taken as the greater of:

$$f_v = 0.07 f_c \quad (4.2)$$

or

$$f_v = [70 + (5 \times h)] \text{ kPa} \quad (4.3)$$

where h is the height of the earth wall in metres above the plane under consideration. If there are no available test data the code proposes a value of shear strength for wind loading with elastic response equal to 0.08 N/mm^2 . Whereas without test data the Australian earth building handbook (Standards Australia, 2002) adopts zero basic shear strength, shear resistance developed along horizontal joints may be checked assuming a coefficient of friction equal to 0.20.

In a permissible stress design approach, the allowable shear stress in the wall may be taken as the square root of the compressive strength of the stabilized rammed earth (Easton, 1996; King, 1996).

4.2.1.4 Modulus of Elasticity

In the absence of direct experimental data the New Zealand Standard (NZS 4297:1998, 1998) takes the modulus of elasticity for earth wall construction as three hundred times the characteristic compressive strength value ($E = 300 \times f_c$). The Australian earth building handbook takes the modulus of elasticity E for rammed earth as 500 N/mm^2 (Standards Australia, 2002). Permissible stress approach used in USA recommends taking the modulus of elasticity as 750 times the rammed earth compressive strength (Easton, 1996; King, 1996).

4.2.2 Serviceability Limit State

Serviceability limit states for rammed earth walls are concerned with appearance (cracking due to excessive deflection or shrinkage) and functional performance (rainfall or frost erosion) of the structure.

4.2.2.1 Deflection

All structural rammed earth members should be designed to have adequate stiffness to limit deflections and associated cracking under compressive service loads. In addition cracking due to deflection can also occur due to in-plane forces acting on the walls e.g. wind loading. In this case cracking is dependent on the wall thickness (Middleton, 1992) but with some empirical guidelines for minimum wall thickness, maximum wall slenderness and provision of openings is usually sufficient for low rise earth building under wind loading.

(a) Minimum Wall Thickness

Minimum recommended thicknesses for rammed earth walls vary depending between design codes. A summary of the main recommendations is presented in Table 4.1 below:

Table 4.1: Minimum Wall Thickness

Reference	Thickness of Wall	
	Internal	External
Standards Australia (2002)	125mm	200mm
New Mexico Code (Tibbets, 2001)	12”(305mm)	18”(457mm)
New Zealand Code (NZS 4297:1998, 1998)	250mm	
Zimbabwe Code (SAZS 724:2001 2001)	300mm	

While the Australian, New Zealand and Zimbabwean recommended external values are broadly similar, the New Mexico Code proposes significantly larger values for the

minimum wall thickness as a result of the considerable seismicity of the region. The lower values proposed by the Australian earth building handbook reflect a wider use of cement stabilised rammed earth construction.

(b) Maximum Wall Slenderness

Recommendations for maximum wall slenderness limit both the likelihood of excessive cracking under service load and compression buckling under ultimate limit state conditions. The New Zealand Standard for engineering design of earth buildings (NZS 4297:1998, 1998) requires that the maximum unsupported clear height and length shall not exceed the following values (where t is wall thickness):

- Simply supported- Height and Length not greater than $18t$
- One end continuous- Height or Length not greater than $21t$
- Both ends continuous- Height or Length not greater than $22t$
- Cantilever- Height or Length not greater than $8t$

For the similar configurations the Australian earth building handbook (Standards Australia, 2002) recommends that height of a freestanding wall should not exceed $10t$. For a wall laterally restrained top and bottom its height shall not exceed $18t$. In both cases the unsupported clear length of the wall should not exceed $30t$. Similar values for unrestrained walls are proposed by the Zimbabwe Standard Code of Practice for Rammed Earth Structures (SAZS 724:2001 2001).

A number of other publications (Easton 1996; King 1996; McHenry 1984; Earth Building Association of Australia 2001, Middleton 1992, Tibbets 2001) recommend similar maximum wall slenderness values based on typical wall thickness.

Both the New Zealand Code and Australian earth building handbook (NZS 4297:1998, 1998; Standards Australia, 2002), following masonry design standards, determines a wall slenderness ratio (S_r) based on ratio of effective height to thickness. Effective height depends on end restraints and are defined as follows:

- $0.75H$ for a wall laterally supported and rotationally restrained both at the top and the bottom; or
- $0.85H$ for a wall laterally supported both top and bottom and rotationally restrained at one of these; or
- $1.00H$ for a wall laterally supported but rotationally free both top and bottom; or
- $2.00H$ for a wall laterally supported and rotationally restrained only along its bottom edge.

In addition to the above limitations on wall height and length, for unreinforced loadbearing rammed earth walls the maximum slenderness ratio required by the New Zealand code shall be not exceed 6, whilst for unreinforced columns the limiting value is 3.

(c) Provisions for Openings

Recommendations for openings in earth walls may be summarised as follows:

- Total combined horizontal length of openings in a wall should normally not exceed one-third of the total wall length ((Standards Australia, 2002; Easton, 1996; McHenry 1984, King, 1996) ;
- The minimum distance between openings for a loadbearing wall of minimum thickness should be between 600mm-1000mm ((Standards Australia, 2002; SAZS 724:2001, 2001; Middleton, 1992; King, 1996);
- Openings should be at least 750mm from the corner of the wall and with minimum 450mm of wall above the crown (SAZS 724:2001 2001); and
- For heavily loaded walls the total area of the openings should not exceed 20% of the total area of the wall (Standards Australia, 2002).

Further recommendations for small arched openings in rammed earth walls are published by Keable (1996) following listing by Lilley & Robinson (1995).

4.2.2.2 Shrinkage

To limit the possibility of cracking due to drying shrinkage and movements arising from thermal expansion and contraction, control or movement joints are normally provided. The horizontal spacing of the joints depends on the soil properties. In general, the control joints in wall panels should be spaced between 2.5 and 5.0 metres (Standards Australia, 2002).

4.2.2.3 Water Penetration & Frost Resistance

Rammed earth walls should be detailed in a such way that the effects of water and moisture penetration, including frost, do not unduly affect the durability of the structure. These conditions are controlled by appropriate material selection and architectural detailing, and are discussed further in chapters 3 and 5 of this report.

4.3 Structural Design of Rammed Earth

4.3.1 General Considerations

As it is clear from the previous section, rammed earth, as most types of earthen construction, is relatively stronger in compression than it is in bending and shear. Therefore, unreinforced rammed earth should generally only be used for structural elements subject to primarily compressive loads, mainly vertical walls and to a lesser extent, columns.

The focus of this report is on unreinforced lightly loaded rammed earth residential buildings; therefore the design guidelines detailed are primarily intended for single- or two-storey wall construction, where, generally, wall height does not exceed 6.5m (NZS 4297:1998, 1998).

4.3.2 Combined Compression and Bending

When vertical and bending forces are combined at the top and bottom of a rammed earth wall, the combined effect can be assessed by regarding the vertical force as acting at a statically equivalent eccentricity (not greater than $\frac{1}{6}$ of the wall thickness) at each end. For sufficient compressive strength, the compressive force applied on a rammed earth section should be less or equal to the product of the slenderness and eccentricity reduction factor times the compressive capacity of the section (Standards Australia, 2002; NZS 4297:1998 1998):

$$\begin{aligned} F_d &\leq K \times F_0 \Rightarrow \\ F_d &\leq K \times f_c \times A \end{aligned} \quad (4.4)$$

where F_d is the design compressive force;
 K is the slenderness & eccentricity reduction factor given in Table 4.2;
 A is the earth cross-sectional area; and
 f_c is the characteristic compressive strength as defined in section 4.2.1.1.

The slenderness and eccentricity reduction factor is based on values used in masonry construction, such as Table 4.2 below reproduced from the New Zealand Standard for engineering design of earth buildings (NZS 4297:1998, 1998). A similar table is included in the Australian earth building handbook (Standards Australia, 2002). Using the eccentricity to thickness ratio and the slenderness ratio of the wall, linear interpolation is utilized to derive the value of K for each individual case.

Table 4.2: Slenderness and eccentricity reduction factor K - (NZS 4297:1998, 1998)

Slenderness ratio (S)	Reduction factor (K)				
	Eccentricity to thickness ratio (e/t_w)				
	≤ 0.05	0.10	0.20	0.30	0.33
6	1.00	0.78	0.56	0.38	0.32
8	0.94	0.73	0.54	0.34	0.29
10	0.88	0.67	0.49	0.31	0.25
12	0.82	0.62	0.45	0.27	0.22
14	0.76	0.56	0.40	0.23	0.18
16	0.70	0.51	0.35	0.20	0.15
18	0.64	0.45	0.31	0.16	0.11

4.3.3 Concentrated Compression Loads

When a concentrated load is acting on a rammed earth member it is generally assumed to disperse through the earth construction at a 45° angle (Standards Australia, 2002; NZS 4297:1998 1998). However the dispersion should not extend:

- Into the dispersion zone of an adjacent concentrated load or member; or
- Beyond the physical boundaries of the structure and any control or vertical joints.

In this case the wall must be designed such that the compressive force applied on a rammed earth section should be less or equal to the product of the concentrated bearing factor times the compressive capacity of the section (Standards Australia, 2002; NZS 4297:1998 1998):

$$\begin{aligned} F_d &\leq K_b \times F_0 \Rightarrow \\ F_d &\leq K_b \times f_c \times A \end{aligned} \quad (4.5)$$

where F_d is the design compressive force;
 K_b is the concentrated bearing factor defined below;
 A is the earth cross-sectional area; and
 f_c is the characteristic compressive strength as defined in section 4.2.1.1.

The concentrated bearing factor K_b is taken as follows (Standards Australia, 2002; NZS 4297:1998 1998):

- For cross-sections at a distance greater than $0.25H$ below the level of the bearing:

$$K_b = 1.00$$

- For cross-sections at a distance within $0.25H$ below the level of the bearing of the concentrated load of the member, K_b is taken as the lesser of the following with $1.00 \leq K_b \leq 1.50$:

$$K_b = \frac{0.55(1 + 0.5a_1/L)}{(A_{ds}/A_{de})^{0.33}} \quad \text{or}$$

$$K_b = 1.50 + \frac{a_1}{L}$$

where A_{ds} is the bearing dispersion area of the concentrated load at the design cross-section under consideration;
 A_{de} is the effective area of dispersion of the concentrated load at mid-height;
 a_1 is the distance from the end of the wall to the nearest end of the bearing area; and
 L is the clear length of the wall.

4.3.4 Out-of-plane Flexural Capacity of Walls

In most areas wind loads should normally not be a problem for rammed earth walls satisfying the minimum requirements outlined in Section 2. According to the Australian earth building handbook (Standards Australia, 2002) when design is required, the out-of-plane forces should be resisted by vertical bending capacity only.

4.3.4.1 Out-of-plane horizontal bending

The Australian earth building handbook (Standards Australia, 2002) claims that there are insufficient data to include resistance from horizontal bending action into the design process for short-term out of plane forces. However, in broad terms, the design horizontal flexural bending moment on the wall should be less or equal to the design flexural strength of the wall. According to the New Zealand Standard for engineering

design of earth buildings (NZS 4297:1998, 1998), the design flexural strength of the wall M_{ch} for rammed earth is:

$$M_{ch} = f_t \times Z \quad (4.6)$$

where f_t is the characteristic bending strength of rammed earth; and
 Z is the section modulus of the cross-section under consideration.

4.3.4.2 Out of plane vertical bending

When designing an unreinforced rammed earth wall to withstand vertical bending moment from actions of a short-term transient nature, the design vertical bending moment on the wall should be less or equal to the design bending moment capacity of the wall (M_{cv}). Therefore, based on The Australian earth building handbook (Standards Australia, 2002), the vertical bending moment capacity of the wall M_{cv} for rammed earth is:

$$M_{cv} = (f_t + f_d) \times Z \quad (4.7)$$

where f_t is the characteristic design bending strength of rammed earth;
 f_d is the design compressive stress at the cross-section; and
 Z is the section modulus of the cross-section under consideration.

The New Zealand Standard for engineering design of earth buildings (NZS 4297:1998, 1998), suggests the use of a virtual work strength analysis for out-of-plane strength for vertical bending. A comprehensive review of this method as applied to earth masonry has been presented by Yttrup (1985).

4.3.5 Design for Shear

4.3.5.1 Shear Capacity

According to the New Zealand Standard for engineering design of earth buildings (NZS 4297:1998, 1998), the design of an unreinforced earth wall subject to shear forces should be such that the design shear force action in the cross section (V_d) is the least of the following:

$$V_d \leq f_v A_v + k_v f_d A_v \quad \text{or}$$

$$V_d \leq 5 f_v A_v$$

where f_v is the characteristic shear strength of rammed earth;
 f_d is the design compressive stress at the cross-section;
 k_v is the shear factor; and
 A_v shear resisting area of cross-section.

Both The Australian earth building handbook (Standards Australia, 2002) and the New Zealand Standard for engineering design of earth buildings (NZS 4297:1998, 1998) agree that for rammed earth the basic shear resistance should be taken as zero unless substantiated otherwise by appropriate testing. The Australian earth building handbook (AS/HB 195:2001, 2001) suggests that a value of shear strength for wind loading with elastic respond should be assumed zero, though shear resistance based on frictional strength of horizontal joints using shear factor of 0.20 is allowed.

4.3.5.2 Design of Shear Walls

The strength capacity of a shear wall under compression and flexure in the direction of the length of the wall should be assessed on the basis of the properties of the whole monolithic cross section of the wall. When two or more shear walls are acting together to resist lateral forces, the loads and actions should be distributed to each individual wall using structural analysis principles by taking into account the relative stiffnesses of the walls under these actions and the effects of openings, if any, in the walls (NZS 4297:1998, 1998). An elementary analysis of this method as applied to a typical two-room two-storey rammed earth house has been presented by Maiti et al (1985).

4.3.6 Design for Torsion

No specific guidelines exist for designing unreinforced rammed earth walls under torsional effects. It is therefore advisable to arrange the layout of the structure in a way enabling to avoid significant torsion development.

4.4 Conclusions

Design recommendations for load bearing rammed earth construction under primarily compressive loads, based largely on unreinforced masonry codes, are available and have been summarised. However, these recommendations have largely been developed in countries, such as Australia and the USA, where cement stabilized rammed earth is most commonly used. The applicability of these limit state and permissible stress design guidelines to natural (unstabilised) rammed earth is less well established. Tests planned later as part of this research project will therefore provide much needed data to develop structural design proposals for UK guidelines.

Architectural Design & Detailing 5

5.1 Design

5.1.1 Outline

Site characteristics, including local climate, topography, wind direction, and sunlight orientation, have an important influence in the design of successful rammed earth buildings. These factors, together with others, will influence the way the house is located and orientated within the boundaries of the site. The architectural plan is also of course influenced by client requirements of aesthetics, functionality, comfort and efficiency.

5.1.2 Site Characteristics

Design in sympathy to local site conditions is now widely recognised as one of the fundamental principles of good 'green' building design. This review does not seek to repeat these principles in any significant detail here, but rather outline their influence on design and construction of rammed earth buildings as mentioned in available published literature.

5.1.2.1 Local Climate

Local climatic conditions have a significant influence on design of successful low energy buildings. Rammed earth is generally considered to be well suited to passive solar design as its high mass and hygroscopic nature contribute to regulation of internal temperature and humidity, reducing the need for active heating and air conditioning systems.

Most sites will experience a wide variety of weather patterns over the course of twelve months. Climate appropriate architecture should reflect that variety. Easton (1996) summarises the very basic principles of good architectural design as a response to the local climate, in the context of rammed earth, as follows:

- in hot humid climates, provisions for wide porches and large screened windows with cross ventilation should be made;
- in hot dry climates, thick walls, small windows and night-time ventilation should be utilised in order to reduce cooling loads by using the thermal mass of the walls to counteract daytime heat gains;
- in climates where the demand for winter heating exceeds that for summer cooling and the winter days are typically clear and sunny, large south-facing windows (in the northern hemisphere) and thermal mass floors should be used to reduce heating loads; and
- in regions where winters are long, cold and grey the best approach is to build small well-insulated buildings with low ceilings and a minimum of exterior wall surface exposed to the weather.

5.1.2.2 Site Topography

The direction and severity of natural slopes on a site is an important consideration. A flat site, away from watercourses, allows greatest flexibility when orienting a building and can

Architectural Design & Detailing 5

simplify the construction, since all foundations can be of equal size (when subsoil conditions are also uniform), and the site can often be more readily accessible during construction. Hillsides can stimulate internal building air movements from prevailing winds, though cold air tends to gather at the bottom of slopes and wind velocities increase further uphill.

In the northern hemisphere a southern or south-eastern hillside is most exposed to the sun and therefore will warm up quickest in the morning. Western hillsides tend to be hotter in the summer while northern hillsides are cooler in the spring and colder in the winter when the rays of the low-angled winter sun glance off the face of the hill (Easton, 1996).

A gentle slope usually enhances the performance of a building. Increasing slope gradient will eventually lead to increased construction complexity, as issues of soil stability and need for retaining structures become increasingly important. The need to divert water draining off the hillside above the structure is crucial and all natural drainage should remain free flowing. Flat and sloping sites that are natural water courses or subject to flooding should be avoided. Ground immediately around the base of a rammed earth building should generally be landscaped to slope away to minimise the risk of water damage.

5.1.2.3 Sunlight Direction

Solar energy is a very important contributor to the comfort of a house. Buildings should be designed in order to trap the heat of winter sun, whilst also providing much needed shading during the summer months. According to Standard Australia (2002) the building should be, ideally, rectangular in plan with overall length 1.5 to 2 times the width in plan. The building's longitudinal axis should be aligned east-west and the north face (south face in the northern hemisphere) should be most heavily glazed (equivalent of 15%-20% of the floor area) to allow the warmth of the winter sun to enter the building.

A suitable eaves length, to allow in low winter sun whilst shading out high summer sun, will depend on latitude of building site. Lower angle winter sun can be allowed in the living spaces through careful positioning of skylights, whilst summer shading can be provided by deciduous plants and created artificially with the use of blinds, screens and curtains.

The benefits of appropriate orientation of the structure with respect to the direction of the sunlight can result in reduced energy bills by as much as 80% (Easton, 1996). Heat is collected and stored within the building elements and then effectively distributed within the building. The environment created by natural heating through radiation is healthier than artificial systems.

5.1.2.4 Wind

Regional architecture around the world had evolved throughout the centuries to wind patterns (Easton, 1996). In cold climates the siting of the structure for maximum winter protection will take precedence, while optimising cooling techniques is more important in hot climates.

Architectural Design & Detailing 5

In cold climates, winter winds can deplete the thermal performance of a structure. Therefore, north-facing walls should be well insulated and if possible protected from the winds with natural features such as large trees.

In hot climates, wind circulation within the structure is more important. In this case, houses can be built off the ground in order to trap the breezes and allow air circulation under the floor. In desert regions where the air is hot, houses should have thick walls and small windows, built close to each other, if possible, in order to maximise the benefits of shading. Wind-trap towers can also be used (Easton, 1996).

Prior to deciding the orientation of the house, a study should be made of the directions of seasonal prevailing winds. Doors, window openings, verandas or sun porches should be arranged to take advantage of cool breezes in the summer and to keep out cold winds in the winter (Middleton, 1953).

5.1.3 Architectural Plans

Design layouts for residential houses around the world are as diverse as the natural climates, cultures and wealth of the people that live in them. As energy efficient buildings should seek to adapt to the individual characteristics of their siting any published plans for rammed earth buildings will have limited general application. Few architectural plans have been published for rammed earth houses. The Indian National Buildings Organisation produced a typical recommended layout of a modest 20 m² rammed earth house intended for landless rural families (Mathour). Further those available from drier and hotter climates, such as south-western USA and Australia, probably have limited application in the UK.

Some of the most significant plans available are those produced during building of the experimental cottages in Amesbury, Wiltshire (Jaggard, 1921). Ten experimental houses, including eight two-storey chalk pisé houses, were built between 1919 and 1921. As part of the experiments straw, 'mud' or cement were also used in some of the buildings. External loadbearing walls are formed from 450 mm thick chalk pisé. Internal space is maximised by using thinner partition walls of fired clay brickwork. Plan layouts for some of these houses are shown in figures 5.1-5.3. Details are considered further as part of project review.

Architectural Design & Detailing 5

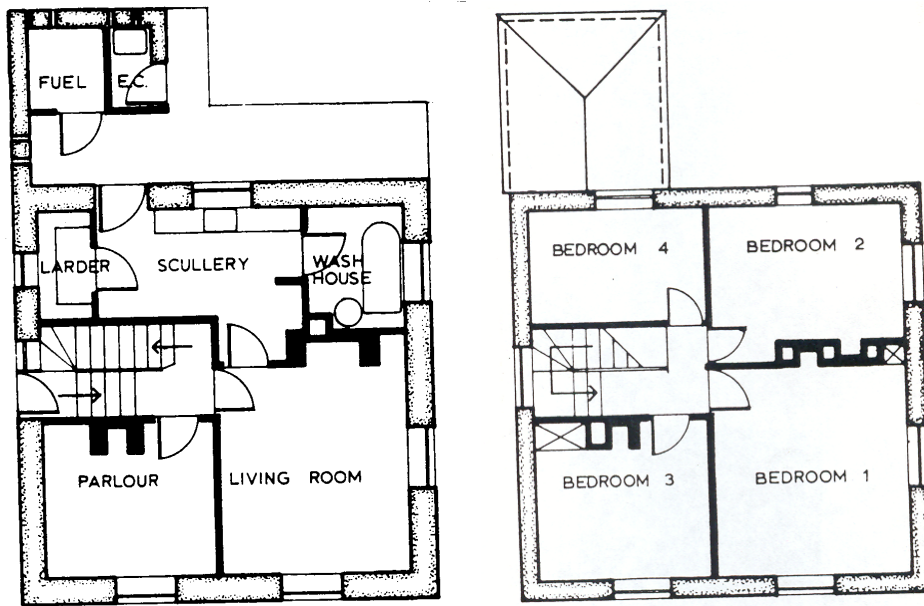

Figure 5.1: Plan of No. 124 Holders Road, Amesbury (Reproduced from Vale, 1973)

Dragons Retreat (formerly West Lake Brake house), designed by architect David Sheppard in the mid 1990s, uses two continuous linear and converging cement stabilised rammed earth walls as both external and internal elements (Wilhide, 2002). As internal load bearing walls they also provide significant thermal mass in south facing glazed conservatory in this low energy building. Externally the walls are free-standing elements within the landscaped garden.

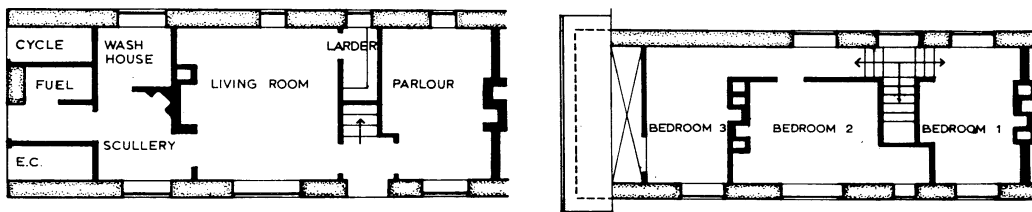

Figure 5.2: Plan of No. 67 Holders Road, Amesbury (Reproduced from Vale, 1973)

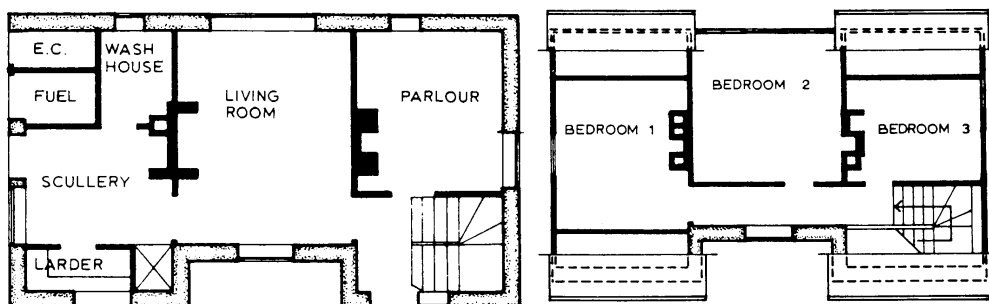

Figure 5.3: Plan of No. 28 Holders Road, Amesbury, prior to demolition (Reproduced from Vale, 1973)

Architectural Design & Detailing 5

5.2 Details

5.2.1 Outline

The detailing of window and door openings, lintels, wall plates, roof anchorages, electrical and water services, and wall fixings in rammed earth buildings are governed by low strength, shrinkage and relatively poor water resistance of the material. As a consequence fixings for door frames or wall plates seek to minimise stresses by spreading loads over as large a volume of the wall as possible. Whereas openings and service conduit are detailed to reduce risk of problems with water entering the earth wall. In the following section published information on details for openings, wall plates and roof anchorages, services and non-structural wall fixings are briefly summarised.

5.2.2 Openings

Openings may be formed either by creating full-height or partial-height sections when building individual freestanding panels of solid earth, by using blockout forms or using structural lintels. Detailing window and door openings up to full height of the wall avoids the need for structural support within the rammed earth. Arched and flat openings formed by blockouts inserted inside the wall formwork are an effective means of providing openings over modest spans up to 1.5 m (Keable, 1994; Easton, 1996). Lintels may be formed from solid timber, concrete, stone or other suitable materials or formed by incorporating steel rebars or rolled sections (Tee or Angle section) inside the rammed earth directly over the opening. Lintels require adequate bedding length to avoid bearing problems, and are capable of spanning over 3 metres in both natural or cement stabilised rammed earth.

5.2.2.1 Frame Fixings

In order to fix frames around openings, a timber framework can be built into the wall (Easton, 1996; McHenry, 1984; NZS 4299:1998, 1998; Standards Australia, 2002). The window or door frame can then be fixed to the timber frame using conventional fasteners such as nails and screws (Standards Australia, 2002). Care should be taken to ensure that all necessary shrinkage can take place without compressing the embedded timber frame, therefore a gap of approximately 50mm between the bottom of the frame and the foundation is recommended (NZS 4299:1998, 1998).

An alternative way of fixing frames onto the openings consists of embedding blocks of timber into the wall during or after construction. Anchoring devices used for other earth construction methods have been used, such as the anchor presented in figure 5.4. Strip and ties can be successfully incorporated into rammed earth walls (Middleton, 1987). Given the potential difficulties of embedding and maintaining the position of this type of fixings, it is common practice in cement stabilised rammed earth construction to fix the frames directly onto the earth walls using conventional masonry fasteners (Standards Australia, 2002). Some standard details for fixing windows and doors are shown in figures 5.5, 5.6, 5.7.

Architectural Design & Detailing 5

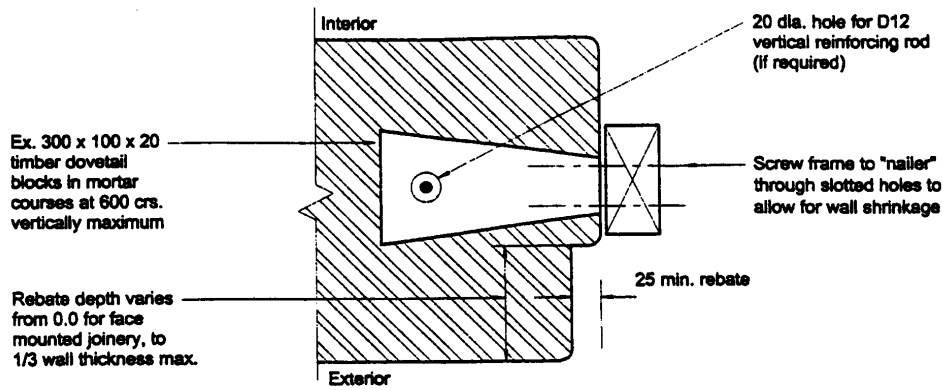

Figure 5.4: Anchor for doors and windows
(Reproduced from NZS 4299, 'Earth buildings not requiring specific design')

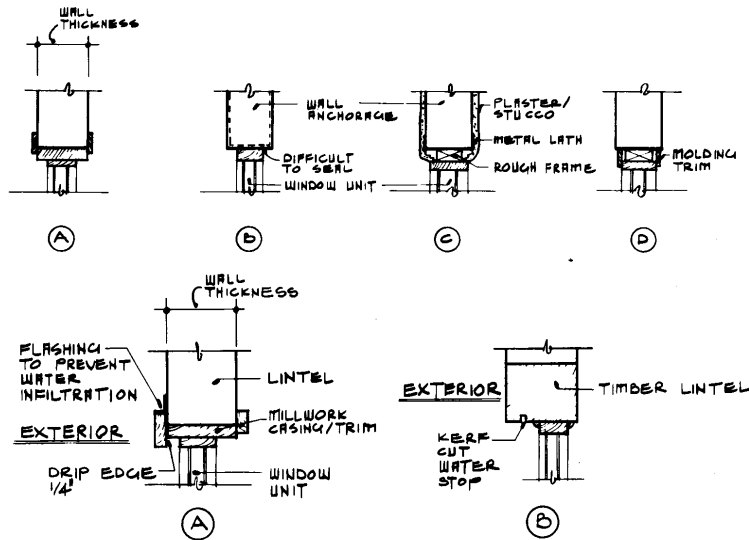

Figure 5.5: Details of window jambs (top) and heads (bottom)
(Reproduced from McHenry, 'Adobe and rammed earth buildings')

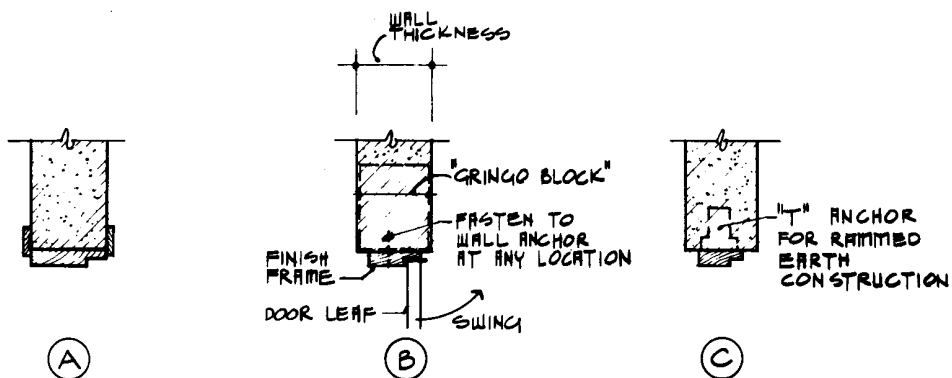

Figure 5.6: Details of door jamb sections
(Reproduced from McHenry, 'Adobe and rammed earth buildings')

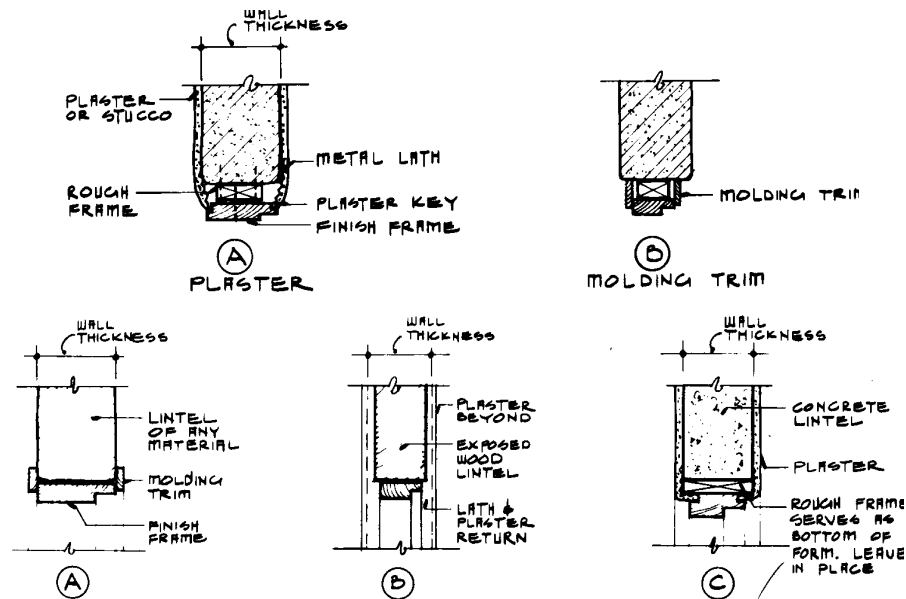

Figure 5.7: Details of door head sections
(Reproduced from McHenry, 'Adobe and rammed earth buildings')

5.2.2.2 Lintels

Lintels can be either from timber, steel, reinforced concrete or reinforced earth (Easton, 1996; Keable, 1996; McHenry, 1984; SAZS 724:2001; Standards Australia, 2002). When designing lintels effort should be made in order to ensure that the loads on top of the lintels are safely distributed either side of the opening. When a series of openings are detailed in a wall, it is common practice to provide one continuous lintel (Standards Australia, 2002). Lintels usually carry loads by simple beam action but composite arching action may also occur if there is sufficient material depth above the lintel (at least 600 mm required in masonry construction). McHenry (1984) has proposed that the minimum lintel bearing, if not part of the bearing beam, should be a minimum of 200mm, while Standards Australia (2002) recommend a bearing length of at least 300mm.

Timber lintels should be protected from excessive damp and wood boring insects (SAZS 724:2001, 2001). The size of the timber required for openings depends greatly on the species and quality of timber used. As a minimum, Standards Australia (2002) recommends a lintel width at least equal to the width of the supporting wall. However, if timber lintels are narrower than the wall width a 50mm thick (minimum) timber block should be provided underneath the bearing across the full width of the wall (NZS 4299:1998). For minimum F5 grade timber (similar to BS 5268 grade C16), the minimum lintel depths should be as follows:

Architectural Design & Detailing 5

Table 5.1: Timber lintels (Standards Australia, 2002)

Clear lintel span, l (mm)	Minimum lintel depth (mm)
$l \leq 1200$	100
$1200 \leq l \leq 1800$	150
$1800 \leq l \leq 2400$	200
$2400 \leq l \leq 3000$	250

Steel lintels, usually angle and tee-sections, can be prone to bearing failure where insufficient bearing length is provided. Therefore, in order to reduce the likelihood of localised failure, steel sections can be seated onto timber-bearing plates enclosed in the wall (Standards Australia, 2002). Suggested minimum steel lintel sections, based on the size of the opening are summarised below:

Table 5.2: Steel lintel sections (Standards Australia, 2002)

Clear lintel span (mm)	Wall thickness	
	125mm	300mm
900	90 x 90 x 6 EA	2 x 65 x 50 x 5 UA
1200	90 x 90 x 6 EA	2 x 75 x 50 x 5 UA
1800	100 x 100 x 6 EA	2 x 100 x 75 x 6 UA
2400	150 x 90 x 8 UA	2 x 125 x 75 x 8 UA
3000	150 x 90 x 12 UA	2 x 150 x 90 x 10 UA

Reinforced concrete lintels may be either pre-cast or cast in-situ. Care should be taken to ensure that adequate reinforcement and adequate cover is provided for the beam in accordance with the local codes and regulations. The concrete lintel can be seated directly on the earth wall or on a mortar bed and, as a minimum, Standards Australia (2002) recommends a lintel width equal to the width of the supporting wall. Detailed reinforcement proposals for concrete lintels for various loading cases are included in the New Zealand Standard (NZS 4299:1998, 1998).

Steel reinforced and cement stabilized earth lintels can be used if the total span of the opening is not greater than 1000mm (Keable, 1996; Standards Australia, 2002). They are usually cast in situ since pre-cast units are prone to cracking. Minimum of two 12 mm diameter bars should be provided (Standards Australia, 2002) while the anchorage zone should be bent to form a 200mm by 200mm anchorage extending beyond the opening. Suggestions with regards to the minimum reinforcement cover vary from 30mm (Keable, 1996) to 50mm (Standards Australia, 2002).

Lintels are potential 'cold bridges' in buildings and consideration therefore needs to be given to their thermal performance and insulation in the detailing of openings.

Architectural Design & Detailing 5

5.2.3 Roof support

Earth is used in many parts of the world for roofing, both as a protective layer against the weather and also as the structure of the roof (Norton, 1997). In the first case earth is a covering material of, usually flat, roofs while the second category includes load-bearing self supported earth vaults and domes. However, both methods generally do not use rammed earth techniques and when they do are very specialist applications and consequently are not considered further in this review. Lightweight timber roofs are most widely used for loadbearing rammed earth structures. Connection details between rammed earth walls and roofs are briefly outlined below.

5.2.3.1 Wall plates, Collar beams and Bond beams

It is common practice in rammed earth construction to provide a wall plate, collar beam, bond beam or roof plate, continuously around the top of walls. Wall plates enhance stability of earth walls of low tensile strength when subject to high lateral loads (wind, earthquake). In addition, wall plates provide interface between wall and roof for connection and anchorage. Wall plates may be either timber or concrete, though McHenry (1984) proposes that steel or wire reinforcing may be a viable alternative. However, the majority of the codes reviewed (SAZS 724:2001, 2001; NZS 4299:1998, 1998; Standards Australia, 2002) only have provisions for timber or concrete wall plates.

Timber wall plates comprise large or small sections embedded onto a mortar bed on top of the wall. Holding down bolts are provided.

Reinforced concrete bond beams are more usually provided where high horizontal forces are expected. As in the case of concrete lintels they can be either pre-cast or cast in-situ. The reinforcement details and arrangement depends on the actual loading and the local codes and regulations (NZS 4299:1998, 1998; Standards Australia, 2002).

5.2.3.2 Roof Fixings

In the absence of a wall plate the roof may be tied down directly to the wall with ties, embedded within the wall (figure 5.8). Ties are usually metallic therefore protection against rust is required (e.g. galvanised). According to the Zimbabwe Standards (SAZS 724:2001, 2001), a roof frame should be anchored at 900mm centres using:

- Two strands of eight gauge minimum galvanised wire, secured to plates and built 450mm minimum depth into the wall, using 150mm long anchors at the bottom; or
- One galvanised or non-ferrous metal strip, minimum 25mm x 2mm, secured to plates and built into wall 450mm minimum, using 150mm long anchors at the bottom.

Architectural Design & Detailing 5

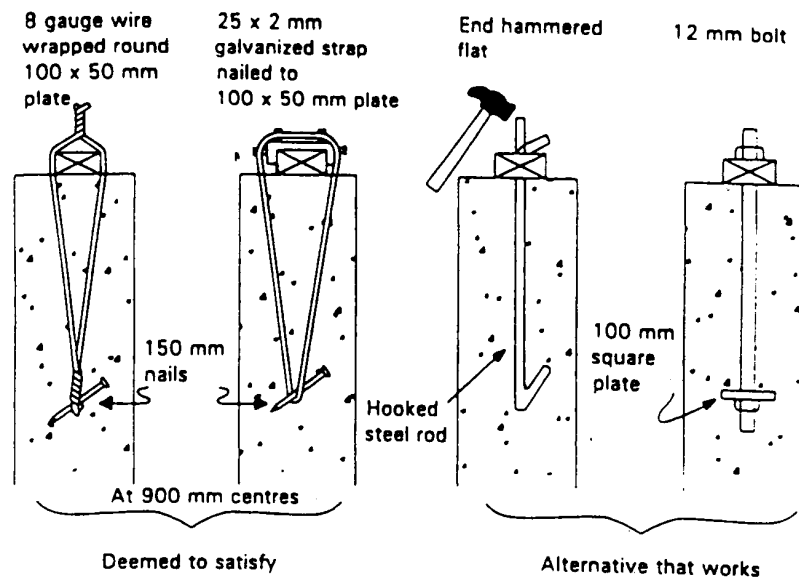

Figure 5.8: Fixings
(Reproduced from SAZS 724:2001, 'Rammed earth structures')

If bond beams are used, connections between the roof and the wall can vary. A typical roof to timber bond beam connection is shown in figure 5.9 while a typical connection with a concrete bond beam is shown in figure 5.10.

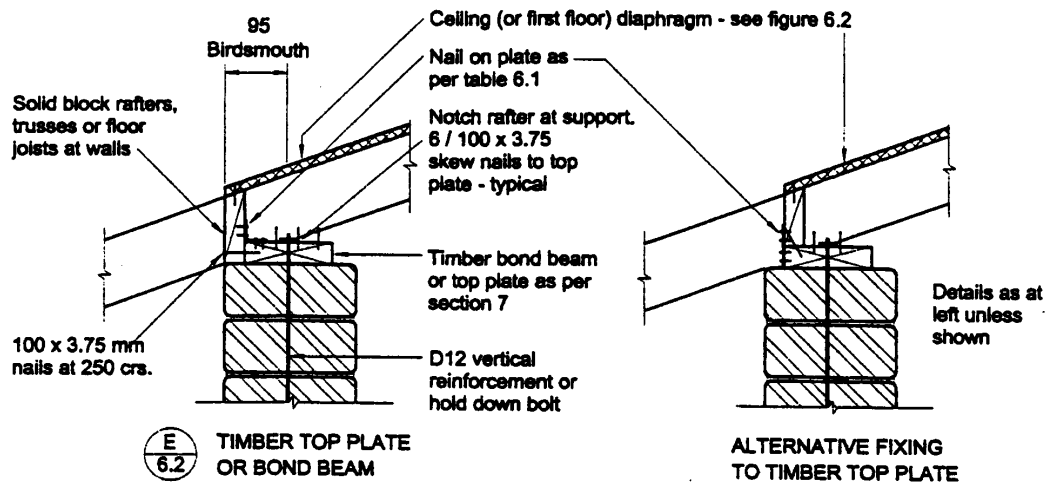

Figure 5.9: Timber bond beam-roof connection
(Reproduced from NZS 4299, 'Earth buildings not requiring specific design')

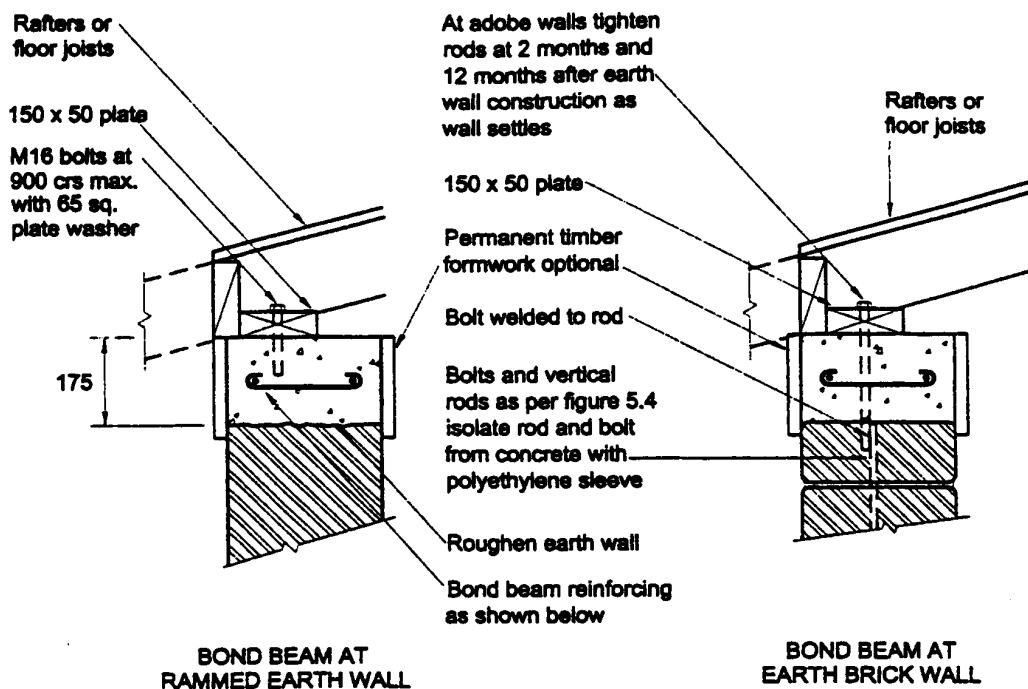

Figure 5.10: Reinforced concrete bond beam-roof connection
(Reproduced from NZS 4299, 'Earth buildings not requiring specific design')

5.2.4 Services

Water is a major agent of decay for earth walls. Therefore, codes and other publications generally recommend not placing plumbing within earthen features (Keable, 1996; SAZS 724:2001, 2001; Standards Australia, 2002). Indeed UK water regulations prohibit the running of water pipes in walls, though they can be run in ducts with removable covers. Ideally these services should be placed below the ground but above the foundation level at a location where it is easy to be maintained and repaired. McHenry (1984) claims that plumbing services can be installed in the earth walls providing that they do not jeopardise the structural integrity of the wall. Pressure testing of the pipes should be performed prior to finishing the wall surface to avoid subsequent leakages. The pipes can be installed either by cutting or coring the earth wall, by placing the pipes directly in the earth prior to compaction or by creating cavities within the walls with blackout forms.

Conduit for electric cables are more readily placed within rammed earth walls. Conduit placed directly within the earth walls during construction should be able to withstand compaction and accommodate any expected shrinkage of the earth wall without damage. Alternatively electrical services can be placed in surface mounted conduit (Easton, 1996). Conduit can also be placed into chases cut into the rammed earth and later infilled, but generally poor colour match makes this an unpopular solution. When vertical or horizontal service ducts are used, conduits may only be inserted in the central third of the wall thickness (Standards Australia, 2002) and should not exceed 10% of that thickness (SAZS 724:2001, 2001). Further, any holes for services should not be wider than 300mm (SAZS 724:2001, 2001) and deeper than 50mm (Middleton, 1987; Standards Australia, 2002).

Architectural Design & Detailing 5

5.2.5 Non-structural wall fixings

The way of fixing domestic wall fixtures on earth walls is similar to the one used for conventional masonry (Standards Australia, 2002). For light fixtures (photo-frames, paintings etc.) nails, screws and hooks, at least 50mm long, can be used (Middleton, 1987). For heavier fixtures, such as shelving the traditional solution is the use of a triple wedge anchor.

Proprietary mechanical or chemical anchors, such as rawl bolts, have also been used successfully. Longer nails or screws like the ones used for fixing roof-sheeting, have also been used for fixing heavy items on earth walls (Middleton, 1987).

5.3 Conclusions

The continued and widespread use of rammed earth across the world is testimony to its success as a building material. Design and detailing of these buildings has evolved and developed in recognition of the material's low strength, relatively high drying shrinkage, poor water resistance and low thermal resistance. Thick walls required to provide sufficient mechanical resistance also offer high thermal mass and improved insulation.

Good detailing inhibits deterioration and minimises maintenance costs. Extended eaves and raised footings protect walls from rainfall. Though services are readily incorporated into walls during construction they are often fixed externally for ease of construction and maintenance. Door and window openings of varying spans are provided using a variety of techniques, including lintels and arches as well as leaving gaps between panels. Non-structural fixings, such as shelving, may also be readily accommodated.

6.1 Soil Preparation

6.1.1 Outline

In the ideal situation sufficient quantities of soil suitable for rammed earth construction will be sourced from the spoil material arising from foundation excavations and other groundworks and/or a suitable borrow pit on site. The ideal soil will require no further treatment (screening or blending) and will be at its optimum moisture content for the chosen method of compaction. Not surprisingly this situation is the exception rather than the rule for rammed earth construction. In-situ soils are likely to require some processing, such as drying or screening, following excavation. In the absence of a suitable in-situ material soil will require transport from a remote source and possible storage on site prior to ramming.

Soil homogeneity is of course important in rammed earth construction both for structural integrity and architectural finish. Therefore, it is important that once the soil has been excavated and prior to placing it into the formwork, variations in soil quality, including most importantly moisture content, are minimised. Pre-processing of soils for rammed earth construction depends on the type of soil, but broadly speaking consists of excavation, screening and mixing thoroughly to correct moisture content.

6.1.2 Excavation

Soil for rammed earth should not include significant levels of organic matter content. Topsoils should be removed and stored for future landscaping, if required. The extent of the topsoil layer is usually indicated by a change in colour and typically includes the groundcover plus, approximately, 25mm to 50mm of soil (Easton, 1996).

There are no special requirements when excavating soil for rammed earth construction. Mechanical equipment such as excavators, bulldozers, angledozers and scrapers can be used for excavation of large volumes of earth. For smaller scale work, a power cultivator fitted out with a cutter has the advantage of combining excavating and aeration operations (Houben & Guillaud, 1994).

6.1.3 Screening

It is not unusual in rammed earth construction to sieve out soil particles exceeding recommended limits. Gravel not greater than 10-20 mm are commonly specified, though depending on relative grading proportions particles exceeding 50-100 mm have been used in some projects. Excessively large gravel pieces and cobbles increase the likelihood of surface finish problems such as boniness, especially around corners and other edges.

Soils imported from a local quarry may be provided screened to pass a specified maximum size. However, soil excavated in-situ or provided un-sieved can be screen sieved on site during preparation prior to mixing. Coarse sieving can be achieved by removing the largest particles manually, usually suitable for those particles having diameter greater than 50mm (Houben & Guillaud, 1994). For finer sieving both static and vibrating screens are available. According to Minke (2000), the most effective screen

is that with a cylindrical sieve set up horizontally or at an angle and with mesh size corresponding to the required maximum grain size.

6.1.4 Pulverization

Pulverization, the breaking down of cohesive aggregations of soil, is by no-means always essential. It is usually required for dry clayey or chalky soils that contain hard lumps that need to be broken down effectively before blending with sand or other additives and prior to wetting, mixing and ramming (Keable, 1994). Pulverization is most effective when undertaken on dry soils. Pulverization can be simply achieved by passing the pneumatic rammer over soil prior to mixing. Electrically powered crushers can consist of steel angles fixed on a horizontal rotating plate and can crush up to 20m³ to 30m³ of soil in 8 hours (Minke, 2000). The pulverizer should be able to handle stony and sandy soils and project the earth some distance to ensure good aeration and proper premixing (Houben & Guillaud, 1994).

6.1.5 Stockpiling

Rammed earth soils should always be compacted at their optimum moisture content for the chosen method of compaction. Limiting soil moisture content during inclement weather is therefore an important consideration to be considered during organisation of works. Measures to prevent excessive wetting of stockpiled soil should be available during rainfall. Similarly soils should be allowed to air dry freely during dry spells if necessary.

6.1.6 Mixing

Mixing is the most essential operation to ensure homogeneity of the soil used. To achieve optimum results Houben & Guillaud (1994) advises undertaking soil screening, pulverising and mixing in one continuous process. In the context of natural rammed earth, mixing is important primarily to ensure an even distribution of moisture content within the soil matrix.

There are several different methods of achieving uniform mix on site such as using rotating-drum type or forced action mortar and slurry mixers, portable concrete batch plants, garden cultivators or simply a tractor or 'bobcat' with a bucket. Old mortar mixing machines with rotating rollers have also been used (Minke, 2000).

Rotating-drum type mortar mixers work adequately when the soil is high in sand and gravel content but in general this is a slow procedure (Easton, 1996). Forced action mixers use revolving arms fixed either vertically or horizontally to mix the soil. Although forced mixers can have a mechanical device for filling the mixer (Minke, 2000) their drums are of limited capacity and therefore are equally slow compared to the drum mixers.

Easton (1996) claims that a type of equipment effective for all soils is the portable concrete batch plant which is a combination of belt conveyor and two hoppers and which blends soil together by a paddle auger and adds moisture as the mix moves along

the trough via a water bar. However this is a very expensive piece of equipment and therefore it has limited practical use.

In most cases for small quantities of soil, a small garden cultivator can give good mixing results (Houben & Guillaud, 1994), while for large quantities of soil probably the quickest way of mixing is with a skilled operator using a bucket-tractor. In this case it is essential to provide a mixing pad (Easton, 1996), a flat clean area located close to the structure for efficient mix preparation. The right amount of water should be sprayed onto the soil and the mix should be thoroughly blended until colour uniformity is achieved. However, as in the case of mortar mixers, it is difficult to achieve a totally uniform mix.

In many rotating drum mixers soils with sufficient clay content required for natural rammed earth are prone to balling during mixing. As the soil is rotated around the mixer cohesive clay elements gather together with other particles to form small balls of soil typically between 2 and 20 mm diameter. As mixing progresses ball size tends to grow. Balling impedes the even distribution of moisture throughout the soil matrix, potentially inhibiting achievement of maximum compaction, and perhaps more significantly influences the finished wall appearance, in that the rammed earth retains its balled structure appearance in contrast to a more uniformly graded matrix.

6.2 Formwork

6.2.1 General Considerations

Formwork in rammed earth construction is used as a temporary support during soil compaction. Like concrete formwork it is required to have sufficient strength, stiffness and stability to resist pressures it is subjected to during erection, placement of the soil, and dismantling. However, unlike concrete, rammed earth formwork can be removed almost immediately after compaction, enabling much faster re-use. As with in-situ concrete construction efficient organisation of formwork is essential to efficient rammed earth construction.

There are several types of formwork and the selection of the appropriate type of moulding system for each application is important, since usually the time spent setting, aligning and stripping the forms is greater than the time spent transporting and compacting the earth (Easton, 1996). Martin Rauch, a leading rammed earth contractor, has commented that typically 50% of his site time is spent erecting, aligning, checking, stripping, cleaning, moving and storing his formwork (Rauch, 2002). Similarly Easton (1996) noted it can take up to three times longer to set the formwork than to ram the wall.

When making a choice of formwork the following general criteria should be kept in mind:

- *strength*- the formwork should be able to withstand the outward pressure of the earth during compaction. Typically pressures during rammed earth compaction are considered to be much higher than general concrete works, though the area and period of time over which the pressure acts is typically much less (Norton, 1997);

Construction Methods 6

- *stiffness*- formwork should be sufficiently stiff to maintain the form without excessive distortion during compaction. Typically, forms should not deflect more than 3mm over the length between the ties under full pressure (Standards Australia, 2002) or when applying a 150kg load at the mid-span between two supports (Norton, 1997; SAZS 724:2001, 2001) ;
- *durability*- forms must be able to meet the expected number of uses under normal site handling conditions and appropriate maintenance, without performance deterioration;
- *adaptability*- the formwork should be capable of accommodating variations in the width and layout of the wall to meet structural and architectural requirements;
- *ease of handling*- formwork must not be too heavy or bulky in order to avoid making assembly difficult and time-consuming;
- *ease of alignment*- formwork parts should include smooth horizontal and vertical slots, comfortable holes for bolts and smooth running ties to allow easy and consistent horizontal and vertical alignment; and
- *ease of compaction*- the shuttering system should not obstruct the compaction process.

The basic elements of any formwork system, traditional or modern, are:

- *shutters*- the two sides of the form;
- *end stops*- the boards which close-off the open ends of the formwork;
- *ties and bolts*- these can be either direct through-bolts, cantilever bolts, threaded ties or ties with wedges (Keable, 1996);
- *props or stays*- the (fixed or movable) vertical posts used to brace the form;
- *spacers*- bolting often requires spacers in order to set the width of the wall. Spacers should be softer than the formwork in order to prevent damage to the form faces (Keable, 1996); and
- *wedges*- for adjustment of the formwork.

6.2.2 Traditional Formwork

Most of the rammed earth structures around the world have been using the same type of formwork for centuries with only small variations. This traditional formwork comprises of two timber shutters usually made out of softwood planks 20-30mm thick (Norton, 1997) and two end stops the width of the wall held together by timber props and rope ties. If 20-30mm thick planks are used, the posts can be spaced at 650-700mm centres further apart. This formwork has been used in almost every continent and was used as recently as the 1960's in America, by substituting the rope ties with steel bolts (Easton, 1996). In England this formwork was used during the 1920's in Amesbury, although it was later modified to include hardwood wedges instead of wire ties and was continuous

Construction Methods 6

around the wall plan (Jaggard 1921). In some parts of the world, including Morocco and India (PoppoSwamy) the formwork is still in use in its traditional form.

The established way of construction requires a well defined wall perimeter of the building on the ground, either in the form of the foundation or by appropriately marking on the ground. The two shutters and endboards are erected at some conveniently chosen starting point along the building line and layers of moist soil are placed into the form and compacted until the form is fully covered with compacted soil. Then the form is disassembled and repositioned in the next location along the line with one end shuttered with an end-stop and the other clamped against the completed section with an overlap at least 150-200mm or more (Norton, 1997). This process is continued along the perimeter of the building until the first layer of wall is completed. Subsequently, the formwork is lifted and clamped on top of the first layer and the same process is followed along the perimeter of the building as previous and then again for the third and successive layers until the desired wall height is obtained. Typically the total depth of each formwork lift varies between 600 and 900 mm (Easton, 1996). Positions of the forms on subsequent layers are commonly offset from the layer below to avoid continuous vertical joints in a manner akin to masonry construction. The uncompacted soil is placed in layers of around 100-150 mm depending on method of compaction and traditional practice.

6.2.3 Modern Formwork

Basic elements of modern formwork comprise sheeting material, against which the earth is compacted, a system of strengthening and stiffening elements (soldiers and walers), ties and bolts, and inclined props to ensure overall stability. Suitable sheeting materials include steel, aluminium, and timber sheeting and planks. As with concrete, the choice of sheeting material and any pre-treatment applied (i.e. release agent) influence the finish of the rammed earth. Supporting members can also comprise steel members and solid timber sections. Steel through ties connecting the two sides of formwork help stiffen it to limit deformation, but leave a hole through the wall that must be filled after stripping and may lead to blemishes in appearance. A variety of different formwork systems, many based on in-situ cast concrete formwork systems, have been used for rammed earth (figure 6.1).



Figure 6.1: Modern concrete shuttering for rammed earth (photo: R.Keable)

Using the traditional formwork gives a different and distinctive finish to a wall. Work is not necessarily slower provided there is enough formwork to always ensure an empty box for the ramming team. The greater the height of the wall the more difficult becomes to set and align the forms, jeopardising the quality of the wall finish. Therefore, following the revitalization of rammed earth construction in the late 20th century, great effort was put towards developing more sophisticated formwork systems to address the existing problems of efficiency and quality control of the traditional forms. Two main types have developed, namely small unit formwork and integral formwork.

6.2.3.1 Small-units Formwork

The concept of this type of formwork is the same with the traditional one. Small individual units are sliding either vertically or horizontally over or next to completed sections of the wall. Various modifications have been developed since the 1950's, including the crawler formwork (CSIRO, 1996) and vertically sliding formwork, but have not been widely used.

(a) *Horizontally Sliding Crawler Formwork*

This type of formwork has been developed by CSIRO Building Construction and Engineering (Middleton, 1952) and can be moved in a horizontal direction without being dismantled. The shutters of the formwork are supported by two built-in rollers, one placed at one end of the form onto the base-wall of the previously completed section and the other at a higher position at the other end of the form, riding along the newly completed section. When a section is completed the shutters are released from the wall surfaces and the formwork, supported by the rollers, is pushed along until the higher roller reaches the end of the section. Finally levelling of the form is established and the shutters are pushed tight against the wall. In Australia and elsewhere this style of formwork did not gain wide acceptance after its introduction in the 1950's and is now rarely used in preference to integral formwork systems based on reinforced concrete shuttering systems.

(b) *Vertically Sliding Formwork*

This type of formwork is ideally suited to the construction of rammed earth walls in framed structures. A type of this slip formwork has been developed by *Forschungslabor für Experimentelles Bauen* – FEB (Building Research Institute) at the University of Kassel (Minke, 2000). Shutters slide within a steel or timber frame spaced at the bottom with only a steel bar, which leaves only a small hole on the wall. At the top the spacer is positioned above the upper level of the wall and hence it does not interfere with the wall-construction process. This kind of formwork, if carefully designed, can significantly accelerate the construction process (Houben & Guillaud, 1994).

6.2.3.2 Integral Formwork

In this category of formwork, instead of building the wall in small panels, large sections of wall are rammed for the entire height or along great lengths of the building. This kind of approach has its origins in the concrete construction technology. The formwork system must allow easy access for compaction, which therefore limits the height that

Construction Methods 6

continuous forms can be built prior to soil placement for slender wall thicknesses. Consequently rather than moving the panels the formwork system is built up as the wall is compacted. Systems developed in Australia and the USA have produced very satisfying results and played a major role in the success of reintroducing earth construction to the marketplace (Easton, 1996).

(a) *Australian Forming System*

In Australia rammed earth builders developed a system of building individual freestanding panels of solid earth that extend to the full height of the finished wall (figure 6.2). Typical traditional panels, usually 2 feet (~610mm) high and 8 feet (~2440mm) long, are used to build sections not horizontally but vertically (Easton, 1996).

Adjacent panels are locked together on the sides and spanned with a continuous timber or steel plate at the top. The length of the section to be built is defined, the end-stops are placed against the foundation and the first pair of face panels is set directly on the foundation and secured against the end-stops. Two sets of tapered steel rods, one at the top and one near the bottom of the panels, hold both panel faces usually every 24 inches (~610mm) (Easton, 1996). When the first row of panel is braced, it is filled with soil and compacted in layers until it is nearly full. Then a second row of panels is set on top of the first using a tongue-and-groove assembly and the process repeated.

Using this system it is easy to maintain the linearity of the wall since there is always a solid base when setting any successive row of panels and the verticality is maintained by the tall, braced end-stops.

(b) *California Forming System*

As in the case of the Australian Forming System, the system developed in California employs full-height endboards and forms stack one on top of another. However there are two main differences. The panels used are significantly bigger, 8 to 10 feet (~2440mm to 3050mm) high (Easton, 1996). Secondly, the ties are spaced further apart to a distance equal to the height of the panels. Therefore with this system a greater volume of earth needs to be rammed at each stage. This and the small number of ties allow the rammers to move freely down the form. The main drawbacks are that due to the height of the panels, soil is lifted at great heights and rammers need to reach down the bottom of the form for the first layers of the wall.

In order to solve problems with trembling endboards when using the above system, Easton (1996) has developed a similar formwork system. The system utilises same plywood panels 1 inch (~25mm) thick with an edge suitable for interlocking form joints, a series of timber planks and standard clamps with the end retainer removed (McHenry,



Figure 6.2: Modern Australian Formwork (Bill Swaney)

1984) to replace the threaded rods. The timber planks are then rested onto the clamps and provide a form of scaffold arrangement and working platform for the builders.

(c) Continuous-wall System

In this system, formwork is placed in a way that allows for the building to be rammed continuously. However, unless the structure is relatively small, it is more common that large sections and not the entire formwork are put in place, since there are, usually, limited forms available and high forms with limited wall thickness restrict access for compaction (Easton, 1996; Pearson, 1992).

6.2.3.3 Speciality Formwork

(a) Corner Formwork

Corners are typically easier to built than straight sections, commercial concrete and Australian formwork systems clip together with standard pieces to allow corners which are in themselves more stable than are straight sections. Formwork for straight sections is then connected to existing free standing corner sections and built as filler panels.

Traditionally, to avoid constructional problems corners have been constructed out of bricks (Keable, 1996). However in modern rammed earth construction there are various corner formwork systems developed to cover a wide range of applications such as modular/non-modular formwork, symmetric/ asymmetric formwork and integral corner formwork (Williams-Ellis, 1916; Houben & Guillaud, 1994). For the most frequent case of wall of constant width, probably the most common formwork is the symmetric style (Middleton, 1992). Once the lower bolts are withdrawn the form can be lifted free of the corner section without any further dismantling. A similar arrangement is employed for partition-wall corners (Middleton, 1992).

According to Easton (1996), corners should be the first part of any structure to be constructed. The formwork proposed by Easton consists of two square forms, with the smaller inside the larger one in order to create the two wings of the corner. The boxes are constructed at full height and the dimensions of the smaller box-form calculated as the difference between the width of the corner form and the wall thickness.

(b) Curved Formwork

Formwork for rounded and curved walls is comprised from same basic components (sheeting material for shuttering supported by timber or steel soldiers and walers), but requires special design and is normally more expensive than that for straight wall sections. A fine example of such formwork was developed by Doca, commercial formwork manufacturers, and used by Martin Rauch for the Church of Reconciliation in Berlin (Kapfinger, O., 2001).

(c) Formwork for Openings

Openings may be formed by using temporary block-outs (Pearson, 1992) or incorporating supporting lintels during construction, though arguably the simplest way to form openings is to extend the opening to the full height of the wall. Openings are not

Construction Methods 6

cut into a solid wall after construction due to the high density and strength of rammed earth (Pearson, 1992). In blocking out robust boxes made out of plywood are made to required dimensions of the openings and inserted in the formwork at the location where the openings are to be formed. After ramming blockouts are removed to provide the opening. Alternatively, in Indian rammed earth openings are formed by incorporating a combination of a flat timber lintel and flat arch of bricks over the required door and window before proceeding with further ramming of earth above (Popposwamy).

(d) *Battered Formwork*

Though rammed earth walls are most generally vertical and parallel sided, battered wall faces, such as seen at the Eden project, are also readily formed (figure 6.3).



Figure 6.3: Battered formwork at Eden Project (photo: R. Keable)

(e) *Permanent Formwork*

Due to increased cost of formwork, attempts have been made to develop permanent (sacrificial) formwork techniques. Permanent formwork made from thin masonry or brickwork (Pearson, 1992) or alternatively a combination of stiff thermal insulation and timber materials has been reported (Minke, 2000), with the additional advantage of improved thermal insulation.

6.2.4 Organisation

Using the modern integral formwork systems described previously (with the exception of the continuous system), a rammed earth wall can be built either as individual freestanding

Construction Methods 6

or as sequential panels. In a continuous system one set of formwork can be used for the whole perimeter of the structure and a bond beam, if required, may be poured.

In so called 'Hit and Miss' construction vertical panels of rammed earth wall are compacted in two stages. Initially alternate panels are rammed full height along the length of the building. On completion of this first stage ramming the subsequent panels then fills the gaps to form the continuous wall. This two stage process has the advantage of reducing shrinkage cracking problems, as initial panels can dry out, and a reduced need for end stops.

The ease of transporting soil from the mixing area into the formwork depends on the type of formwork used. Obviously for full height panels the task of transporting the soil in the forms is more difficult. The problem of transporting the soil is one of the major problems in rammed earth technology (Houben & Guillaud, 1994).

Traditionally soil is transported manually, using baskets and buckets raised by scaffold or ladder. In modern construction soil mixing and lifting is commonly undertaken using a 'bobcat' or similar plant (figure 6.3). In high walls craning the soil up to the formwork becomes a feasible option. Other options include conveyor belts, screw augers, pumps and air-delivery systems, but the efficiency of these methods is questionable (Easton, 1996).

Inclement wet weather has a significant influence on programming and progress of rammed earth works. Control of soil moisture during compaction and subsequent drying is essential to success. Walls need protection from wet weather and frost. Consequently walls are often built under shelter of a completed roof structure. Alternatively, walls need temporary shelter. The warmer, though not necessarily drier, spring and summer months are preferable in the UK.

6.3 Soil Compaction

6.3.1 Dynamic Compaction

In rammed earth loose soil is compacted in layers between temporary forms. Traditionally this was undertaken manually, but over the past 50+ years has been replaced by pneumatic, vibrating plate and sheep's foot roller compactors. Depth of loose soil added in each layer varies depending on compactive effort, soil type and required formwork, though depth of around 100mm is most common.

6.3.1.1 Manual Compaction

The traditionally used tool for compacting soil in rammed earth construction is a hand tamper, usually comprised of a heavy block of timber fitted onto a handle. The most important factors when considering using a manual rammer are the head's material, the weight of the rammer, the shape of the head and the area of the head-face and finally the length of the handle. From the above factors the weight of the rammer is probably the most important factor since excessive rammer weight requires more physical effort without improving compaction characteristics (McHenry, 1984). The suggestions of

various authors with regards to the ideal properties of manual rammers are summarised in Table 6.1.

Table 6.1: Manual Rammer Characteristics

References	weight of the rammer	shape of the head	head materials	area of the head face	length of the handle
Houben & Guillaud, 1994	5-9kg	various	timber/ metal	ideal 64cm ² >225cm ²	1.3-1.4m
Keable, 1996	5-10kg	circular	timber/ metal	50-110 cm ²	1.5-1.8m
Middleton 1952, 1953	14-18lb (6.3-8.2kg)	conical	timber with steel bottom plate	4-6in ² (25-39cm ²)	5ft (1.5m)
Norton, 1997	7-10kg	prismatic	timber/ metal	80-100cm ²	1.5-1.8m

Tests have indicated (Keable, 1996; Norton, 1997) that the rammer should be dropped 150mm-300mm with moderate force for optimum results. Although effective, manual compaction is very labour intense and time consuming. A team of three workers can typically place between 2 and 4 cubic yards (1.5 - 3 m³) per day of rammed earth using hand-ramming techniques only (Williams-Ellis, 1916). Though largely replaced by pneumatic or vibrating plate compactors in western countries, manual compaction is still widely used in areas of difficult access, such as tight corners and curved surfaces.

6.3.1.2 Pneumatic Compaction

Mechanical compaction is preferable to hand ramming, when possible, since the ramming time can be reduced to half compared with the time required for manual ramming (Middleton, 1953).

Mechanical impact rammers usually operate with compressed air to repeatedly lift and drop the striking head of the rammer. The ideal impact rammer should have long-stroke distance, moderate speed and weight to make it safe, especially when working at the higher levels of the wall and slender tamper, to fit the corners of the forms. The tamp face is typically circular (Figure 6.4) and should be between 70mm-150mm in diameter (Keable, 1996). High-speed jack hammers and petrol driven hammers are not suitable (Middleton, 1952).



Figure 6.4 Pneumatic rammer

6.3.2 Vibrating Plate Compaction

Vibrating plate compaction is generally regarded as unsuitable for rammed earth construction (Houben & Guillaud, 1994; Norton, 1997). However, variations of vibrating rammers, such as the sheep-foot rammer used during the construction of the Church of Reconciliation in Berlin (Kapfinger, O., 2001) have proved successful.

A type of vibrating rammer in the form of a vibrating plate has been developed by *Forschungslabor für Experimentelles Bauen* – FEB (Building Research Institute) at the University of Kassel (Minke, 2000) which is electrically powered. Its most important part is the specially shaped base which allows the apparatus to move within the formwork by itself while compacting loose earth layers 70mm thick. In general, vibrating rammers are usually heavy and expensive and have limited application in earth construction. However, wacker plate vibrating compactors have also proven useful in compaction of earth floors.

6.3.3 Compactive effort

The compactive effort of manual, pneumatic and vibrating rammers is unclear and varies depending on use, level of exposure to earth, soil type and soil moisture content. Practitioners often refer to a ringing sound emitting from the pneumatic rammer head impacting the compact earth as the indication of adequate compaction having been attained (Williams-Ellis, 1916). Australian rammed earth builders liken pneumatic compactive effort as similar to Modified Proctor compaction, though there is little experimental evidence to support this.

6.3.4 Horizontal Joints

Following compaction some guides recommend treating top surface before adding subsequent layer (Middleton, 1992; United Nations, 1958). Brushing off loose material and scabbling or scoring surface is believed to improve bond and reduce likelihood of (delamination). However how effective this is in improving physical properties is unclear and warrants further study. Surfaces which have dried out overnight or longer should generally be treated and moistened prior to works recommencing, though it is preferable to complete full panel height before work ceases.

6.4 Productivity

Productivity of rammed earth construction is dependent on many factors, some that are easy to control such as formwork system and compaction method and others that are not, such as weather conditions. Organisation of formwork is certainly one of the most time-consuming elements of rammed earth, perhaps accounting for over 50% of site time during some projects.

Operations (and factors) influencing on-site productivity include:

- Material preparation:
 - excavation;
 - screening;

- drying (soil moisture content);
- pulverisation (soil type);
- mixing (soil type); and
- transport and lifting (weight).
- Wall characteristics:
 - size;
 - width; and
 - height.
- Formwork;
 - erection;
 - alignment (plan and verticality);
 - dismantling;
 - cleaning; and
 - lifting (weight).
- Compaction:
 - method; and
 - labour experience.
- Weather conditions:
 - Rain; and
 - Temperature (frost).

Consequently it is not surprising that productivity rates quoted for rammed earth vary between 5hrs/m³ to over 25hrs/m³ (CRATerre, 1982). However productivity rates for finished wall using modern equipment, more typically, vary between 5-10hrs/m³/person.

6.5 Conclusions

The following conclusions have been drawn from this stage of the review:

- Soil homogeneity is important in rammed earth construction in order to ensure minimum localised failure. The procedures that are required in order to reduce the variations in soil quality depend on the type of soil used;
- Several types of formwork exist. The selection of the right type of formwork for the right application is important in order to increase the efficiency during the construction phase of an earth project;
- The right type of formwork for a given application depends on the level of mechanisation available, the relative labour cost and the type of structure. For simple structures more traditional formwork might be appropriate;
- Architectural forms with non-linear surfaces are more time consuming and expensive to build; and
- When possible, mechanical compaction of soil is in the UK usually, the preferred method of compaction.

In summary, the thorough careful planning of the temporary works and methods of construction the time-delays and cost implications during the implementation phase of a rammed earth project can be successfully controlled, though possible delays due to inclement weather will need to be accommodated in scheduling works.

7.1 Material Quality

7.1.1 Outline

Quality is a measure of the features and characteristics of a product that bear on its ability to satisfy its stated or implied needs (BS EN ISO 8402, 1995). Quality control involves operational techniques and activities aimed at monitoring performance and measures to correct unsatisfactory performance. Broadly speaking quality control procedures are either precautionary or confirmatory. In the context of rammed earth precautionary procedures relate to the walling material and the selection, storage and preparatory conditions of the soil. Confirmatory procedures relate to the measurement of the finished wall characteristics (density, strength, erosion resistance, dimensional variation) against agreed specifications.

7.1.2 Selection

Material selection should be consistent with the design requirements with regards for colour, grading, plasticity, strength and erosion resistance of the soil. Tests should be performed as outlined in the relevant materials section and the results should satisfy the minimum provisions of the relevant building codes and the requirements of the design specifications.

If locally available soils do not conform to the minimum acceptable design standards then the decision whether to either import soil from a remote location or improve the local soil by using a stabiliser is necessary. Alternatively blending of quarried aggregates sourced close to the construction location and mixed on-site might be a viable option. This alternative has been used extensively in Australia and has provided cement stabilised rammed earth walls of constant quality in a variety of projects (Oliver & Whybird, 1991).

7.1.3 Weather Conditions

Weather, and the site specifics of dealing with it are not well documented in the literature, although Clough Williams Ellis (1999) is instructive. In the UK it seems that no month is statistically more or less prone to rain than any other, while frost is more likely in winter. However there does not seem to be a 'dry building season' as some have suggested, only the need for regular and prompt covering of newly built material and on going work.

Rammed earth walls are built at optimum soil moisture content. Compaction at the optimum moisture content improves resistance to weathering, including that immediately following construction while drying. Newly built walls need to dry out, this is particularly important to surface quality of finished walls.

Plastic sheeting is extremely useful in keeping fresh walls dry from rain, but has other side effects. It may slow the drying process if too tightly applied. Plastic may also concentrate water into damaging runoff, thereby damaging the new wall more than a light shower of rain.

7.1.4 Storage

Materials should be stored in such way that their performance is not impaired. Soil for use in rammed earth should not be allowed to become too wet. A sheltered area in which to work with the rammed earth is therefore necessary in during wet periods (CAT, 2000).

7.1.5 Preparation

7.1.5.1 Pulverisation

The majority of soils require minimum crushing or pulverisation before processing. However the more clay present in the soil the more important pulverisation becomes. In order to increase the efficiency of pulverisation it is important that soil is not very wet but equally not very dry and that, if needed, additional passes through the mixing machine are made. For soil cement it is proposed (ACI Materials Journal Committee Report, 1990) that 80% of the soil should pass the No. 4 (4.76 mm) sieve.

A test to determine the degree of pulverisation can be performed on site. This consists of screening a representative sample of soil through the required sieve-size, and determining the ratio of the retained over the passing dry weight of soil. On site and for practical purposes, wet weights of materials are considered to give a reasonable approximation of the degree of pulverisation (ACI Materials Journal Committee Report, 1990).

7.1.5.2 Moisture Content

The water used for rammed earth should be from a clean source free from organic matter and any other harmful substance (SAZS 724:2001, 2001). As discussed in the relevant materials section, the optimum moisture content for each soil should normally be determined in the laboratory prior to the start on site. This percentage is used as a guide for field control. It has been recommended for cement stabilised work that the approximate percentage of water added to the soil should be equal to the difference between the optimum moisture content and the moisture content of the soil, plus an additional 2% in order to account for evaporation that normally occurs during processing (ACI Materials Journal Committee Report, 1990).

An estimation of the right moisture content on-site can be made by observation and feel, using the drop test described previously. Checks of the actual moisture content may be made daily using a conventional or microwave oven drying (ACI Materials Journal Committee Report, 1990).

7.1.5.3 Mixing

Soils should be well mixed prior to ramming in order to achieve uniformity and consistent quality. Mixing methods should comply with those specified and should ensure that specified proportions are controlled (Standards Australia, 2002).

The uniformity of the mix should be checked at regular intervals during mixing. A mixture of uniform colour and texture from top to bottom is satisfactory while a mixture that has a streaked appearance has generally not been blended sufficiently (ACI Materials Journal Committee Report, 1990).

7.1.5.4 Compaction

Compaction should be carried out in order to achieve a specified minimum proportion of the maximum soil density, usually specified as between 95% and 98% of the Proctor maximum dry density.

7.2 Construction Quality

7.2.1 General Considerations

When an earth wall is built it is important to check whether the construction methods used have resulted in a structure fit for the purpose it was built and in accordance with the design specifications. The main aspects that need to be checked are the geometry of the structure (in the form of tolerances and deviations), the density, strength and erosion characteristics of the wall.

7.2.2 Construction Tolerances

Earth walls should not deviate excessively from the specified design geometry. Construction tolerances should be specified before construction and should comply with any values specified by the local building codes. Table 7.1 (next page) summarises suggested tolerances in earth construction as proposed by Standards Australia (2002) and New Zealand Standard (NZS 4298:1998, 1998).

These tolerances are significantly greater than those applied to other similar materials, such as brickwork (BS 5628-3:2001, 2001). Detailing modern fixtures, such as windows is very difficult with such high tolerances in variations in wall dimensions.

7.2.3 Dry Density

There are various methods of determining the in-situ density of the soil, the most direct being by sand replacement method or core sampling. Other more sophisticated methods, such as the nuclear method (ACI Materials Journal Committee Report, 1990) are more complex and generally not necessary. Indirect measures of wall density, and strength, used in rammed earth construction include cone penetrometer and rebound hammer tests based on similar procedures used in either geotechnical engineering or concrete technology. For example, a surface rebound hammer test was used to measure wall quality during construction of the Chapel of Reconciliation in Berlin.

7.2.4 Compressive Strength

The compressive strength of the built earth walls should not be less than the unconfined compressive strength specified in the design. Preparation of either cubes or cylinders is common practice, but possible variation in applied compactive effort is a significant drawback to this approach. Alternatively indirect compressive strength testing has been recommended (SAZS 724:2001, 2001) as described previously. More accurate results can be obtained by core sampling and crushing of the cylindrical or cubical specimens in a compression cell as specified in the relevant materials section. Obviously there is only limited number of core samples that can be extruded and therefore core selection from as many representative wall locations as possible is important.

Table 7.1: Tolerances in earth or masonry construction

Item	Tolerance		
	Standards Australia, 2002	NZS 4298:1998, 1998	BS 5628-3:2001, 2001
Horizontal position of any earth building element specified or shown in plan at its base or at each storey level	±30mm	±45mm	±10mm
Deviation within a storey from a vertical line through the base of the member	±25mm per 3m of height or ±0.1 times thickness of walls, whichever is less	±35mm per 3m of height	±10mm per 3m of height
Deviation from vertical in total height of building (from base)	±25mm	±40mm	±14mm per 7m of height
Relative displacement between load-bearing walls in adjacent storeys indented to be in vertical alignment	±30mm	±40mm	N/S
Deviation (bow) from line in plan in any length up to 10m	Single curvature: ±30mm	Single curvature: ±45mm	±5mm per 5m length
Deviation from vertical at surface against which joinery is to be fitted	±10mm	±30mm	±10mm
Deviation from design wall thickness	-20mm, +40mm	-20mm, +40mm	±10mm
Position of individual rammed earth formwork panels	N/A	±4mm	N/S

7.2.5 Erosion Resistance

It is not common practice to perform erosion tests on finished walls. If prior laboratory erosion tests have achieved acceptable results, and the in-situ wall has achieved the minimum required density and compressive strength, erosion resistance is often taken as satisfactory. However, this does take into account surface defects arising during construction process that come to light during stripping of the formwork. If erosion testing is required this could either be undertaken in the laboratory on cored specimens or spray erosion test apparatus could be readily adapted for field testing, though as stated earlier is rarely used.

7.2.6 Surface defects

On removal of formwork a variety of surface imperfections and defects to rammed earth walls can come to light. Some of these features, such as layering, variation in density and colour, are intrinsic to rammed earth construction. Others, such as boniness (the exposure of gravel caused by the lack of fines material) and shrinkage cracking, arise from poor compaction and/or use of poorly graded material for example. Disputes between rammed earth contractors and clients concerning wall finish have become increasingly common in Australia. Construction of test panels to establish agreed finish before works commence has therefore become recommended practice (Standards Australia, 2002).

7.3 Conclusions

Material and production parameters have a considerable effect on the quality of rammed earth walls. Optimising material handling and production can be decisive for the acceptability of the end-product.

A variety of simple field tests to ensure compliance with design parameters are in widespread use. Nevertheless quality control measures for earth structures are not fully established or widely recognised and variations between tests can be expected (Crowley, 1997). Further test development to improve reliability is important.

Performance requirements and tolerances should be clearly and explicitly defined, including test panels, prior to the construction phase and should be in accordance with local building codes. Tolerances for rammed earth construction should reflect intrinsic characteristics of the material but existing published limits are too broad for more modern design applications. Any variation from the specification should be carefully examined and assessed and the implications of the deviation analysed and communicated between all parties involved before any further decision.

8.1 Material & Design

8.1.1 Outline

Foundations for rammed earth buildings must satisfy the same requirements of strength, stability and serviceability as foundations for other similar types of building. Building foundations should be of adequate size to safely transfer building loads to the bearing ground without excessive stress or settlement. As low strength mass walling elements rammed earth walls are most typically built onto shallow strip footings, similar to that required for masonry walling or onto ground floor slabs. Foundations should also be at sufficient depth to avoid seasonal changes due to freezing, thawing and vegetation growth. The foundation material should be able to resist corrosion or deterioration due to any harmful materials present in the soil. Finally the foundation must be easily and safely built and meet required environmental standards.

Foundation strength is governed by two main factors, the type of structure and corresponding imposed loading on the footing, and the characteristics, most importantly bearing capacity, of the underlying soil strata.

8.1.2 Foundation Types

Historically foundations were often absent in earth structures, with walls built directly onto bearing soil or very shallow footings or slabs. McHenry (1984) claims that this was due to an apparent resilience of earth walls not found in more conventional materials, which reduced the importance of foundations. As the strength of earth wall material is generally similar to or perhaps even less than that of the bearing strata, footings that spread high loads are not required. Most importantly footings at the base of earth walls are required to protect the earth wall from moisture ingress from the ground. Nowadays the use of foundations is a requirement of modern codes, and in some cases (Standards Australia, 2002) standard solutions are provided based on the soil classification and type of construction.

There are two main types of footings used in rammed earth construction, the strip footings and the footing slabs (with or without stiffeners). Alternative footing systems, which are proved to be suitable for each particular application, are also used.

Traditionally strip footings are the most widely used and are formed symmetrically about the centre line of the wall. They should, as a minimum, be as wide as the wall and should extend above the cleared ground level. Slab footings usually utilise the ground floor slabs as a continuous foundation and are often stiffened with ground beams around regions of heavy load concentration such as below load-bearing earth walls.

8.1.3 Materials

Almost exclusively modern slab footings are made out of reinforced concrete. The ground beneath the slab is cleared and a granular fill placed either on a solid base or on firm fill. Some recommendations suggest that the thickness of the granular fill should not be less than 75mm nor greater than 600mm (NZS 4299:1998, 1998).

Traditional strip footings are made from stone masonry and, more later recently, burnt clay bricks. Typically strip footings in modern housing are mass concrete. Middleton recommends that reinforced concrete foundations should be the preferred option (1952)

unless financial or other reasons justify the use of stone foundations. In some circumstances cement stabilised earth foundations can be used, though according to the Australian earth building handbook (Standards Australia, 2002) stabilised earth footings should only be used if:

- The site is mostly sand and rock with little or no ground movement from moisture changes;
- The site is predominately dry, well drained and in a region of low seismicity;
- The length of the building is less than 25m;
- No walls are greater than 3m in height; and
- No garden beds or trees are placed in close proximity to the footing.

In broad terms earth foundations should be used with caution and ideally an impervious coating should be placed on the exposed sides of the foundation below the ground level (Houben & Guillaud, 1994; Keable, 1996).

8.1.4 Design

Where necessary, foundations need to be designed to ensure they can sustain full strength of shear walls without overturning or damage (Hodder). The design of foundations should then be carried out by a suitably qualified and experienced geotechnical or structural engineer in accordance with the provisions and principles of the local codes for foundation design. Foundations for lightly loaded low rise rammed earth buildings often do not require rigorous engineering design but can follow rule of thumb guidelines.

Strip footings of mass or reinforced concrete should be formed continuously along the whole length of the earth walls. They may consist of two parts: the lower foundation, or spread footing, and the upper foundation, or stem wall. The following table summarises the guidance given by various codes on the geometrical properties of reinforced concrete spread footings:

Table 8.1: Geometrical properties of reinforced concrete spread footings

Item	Standards		
	SAZS 724:2001, 2001	Standards Australia, 2002	NZS 4298:1999, 1999
Foundation width (W_f)	from equal to wall width (W_w) to max 500mm	from equal to wall width or 300mm to max 400mm	from equal to wall width or 280mm to max 450mm
Foundation depth	$(W_f - W_w)/2$ or W_w whichever is larger	300mm-400mm	min 150mm in rock or 300mm in other soils

If ground freezing is a problem, footings should extend into the ground to an adequate depth in order to prevent any freezing occurring underneath the base of the foundation

(Easton, 1996). Concrete stem walls extend from the top of the footing to the underside of the earth wall. According to the New Zealand Standard (NZS 4299:1998, 1998) the stem wall should be:

- A minimum of 225mm above the finished exterior ground level;
- A minimum of 50mm above the interior floor level during construction before weatherproofing of the roof;
- A maximum of 600mm above the cleared ground level; and
- A minimum of 150mm above permanent paving.

The Australian earth building handbook (Standards Australia, 2002) on the other hand requires that the minimum recommended earth wall base height above finished ground level should be 150mm if the site is dry or if the adjoining area is paved and sloped away from the wall or 225mm in any other case. Similar values are proposed by Middleton (1953).

For stabilised earth foundations the minimum suggested footing depth is 400mm and the minimum footing thickness should be equal to the wall thickness but not less than 300mm (Standards Australia, 2002).

8.2 Details & Construction

8.2.1 Details

The ground immediately around the base of the wall should be well drained and footings should be protected from water infiltration. Where termites are a problem, adequate protection should be provided. Since termites are only very rarely a problem in the UK this type of protection is considered beyond the scope of this document. On the other hand rat infestation is a fairly common problem in cob construction, where broken glass or pure clay laid at the base of the wall during construction or raised footings have been used as deterrents (Pearson, 1992). Extent of rat infestations in historic rammed earth is unknown.

8.2.1.1 Drainage

Accumulation of standing water adjacent to the footing should be avoided by installing necessary surface and underground drainage.

Surface drains usually consist of paving units sloping away from the footing to a specified collection point. The Australian earth building handbook (Standards Australia, 2002) suggests that the slope should not be less than 1 in 20 and the collection point no further than one to two metres. Houben & Guillaud (1994) on the other side claims that impermeable surfacing over the soil around footings should be avoided in order to allow moisture in the soil to evaporate. Hard paving such as rubble with permeable filled joints can provide such a surface. In this case, a suitable soil gradient of 2% or more should be used.

Underground drainage should be built to a convenient ditch close to the foundations at a short distance, 1.5 metres approximately (Houben & Guillaud, 1994). Channels of burnt clay or other suitable materials can be laid at the bottom of the trench, which then collect the water and remove it by means of a regular gradient. Alternatively trenches with at least 200mm deep fine gravel, often known as “french drains” can be used to remove the excess water (Keable, 1996).

8.2.1.2 Damp-proofing

In modern rammed earth building damp proof courses are provided in order to prevent moisture penetrating from the subsoil into the building. In traditional earth building damp proofing was not provided, any moisture entering the wall was able to dissipate through the wall mass as part of breathing wall system of construction. A convenient position for DPC is immediately on the top of the foundation (CSIRO, 1996).

It is important that any damp-proof courses are consistent with the local building codes and at the same time are relatively flexible and therefore are unlikely to fracture due to shrinkage in the wall or minor foundation movement (Middleton, 1952). A widely used form of damp-proofing in rammed earth is bituminous paint (Hodder; Houben & Guillaud, 1994; Middleton, 1952; Middleton, 1953; NZS 4299:1999, 1999). However, this is not acceptable for masonry walls in the UK. Damp-proofing materials used more widely in masonry, and some rammed earth walling, include polyethylene (Norton, 1997), bitumen/sheet metal composites, bitumen DPC, mastic asphalts, lead or copper sheeting

(Middleton 1952), bitumen polymer, dense bricks and slate. Other materials used in rammed earth internationally include water repellent cement (Houben & Guillaud, 1994) and chemical treatments.

8.2.2 Construction

Concrete footings can be either poured separately or in conjunction with the stem wall. Excavation for foundations should remove all topsoil and if the bottom of the trench is not firm, a compacted layer of fill with minimum bearing capacity between 50 and 100kN/m² (Standards Australia, 2002) should be placed. Any required formwork is set in place and the reinforcement installed. Any services going through the foundation are ducted and the trench is cleared of vegetation and any other organic material or debris. Concrete is then poured in the trenches, compacted using a concrete vibrator and moistened with water and covered with plastic sheeting. Forms are then left in place for as long as necessary and concrete curing with water is continued for at least seven days before rammed earth works commence (Easton, 1996).

Stabilised earth footings are constructed in a similar manner. Trenches are excavated and at the bottom a 20 to 50mm thick blinding layer of clean quarry sand or weak concrete is placed (Standards Australia, 2002). If chemical damp-proofing is not used, the damping proof membrane is installed to line the footing. The cement stabilised mix is then poured in the trench in layers approximately 100mm thick (Norton, 1997) and compacted in order to obtain at least 98% of the Proctor dry density. During compaction, care should be taken not to punch the damp-proof course and any tearing should be adequately repaired and sealed. After compaction the material should be covered with plastic sheeting or damp hessian sacks and left to cure undisturbed for at least seven days (Standards Australia, 2002).

8.3 Conclusions

Foundation design for rammed earth buildings is very similar to that for similar low rise buildings. Slab and strip footings are the most common types of footings encountered in earthen construction. Concrete strip footing is the most widespread modern mode of foundation used for rammed earth buildings, though cement stabilised earth footings are also used in Australia. The size of footings depends on the type of the supported structure and the soil bearing capacity underneath the foundation. It is important that foundation is of sufficient depth to avoid frost underneath the foundation and that the ground immediately around the base of the wall is well drained and footings well protected from water infiltration. The installation of surface and underwater drains and damp-proof courses is therefore generally considered essential.

Maintenance & Repairs 9

9.1 Maintenance

9.1.1 Outline

The many many historic examples from around the world are a clear demonstration of the durability of natural earth as a material in a wide variety of building types, techniques, climates and cultures. Key factors in this success are good design and detailing followed by regular maintenance and repair when necessary. Though published advice is available for conservation and repair of historic earth buildings, there is little published information relating to the maintenance of new earthen buildings. Although some general guidelines on the subject are provided in the Australian earth building handbook (Standards Australia, 2002), more specific advice is generally scarce among the available literature on rammed earth construction. Consequently this review considers, where appropriate, the maintenance and repair of earthen buildings in general.

9.1.2 Maintenance Work

Maintenance of building fabric is an essential activity during the life of all buildings. Though maintenance requirements of earthen buildings may be considered higher than we have come to expect for some industrialised materials, such as fired bricks and metal clad buildings, rammed earth buildings do provide durable low maintenance dwellings. It is important that a detailed maintenance schedule for rammed earth structures is established and sustained.

Water is a major agent of decay for earth buildings. Therefore any routine maintenance work should primarily include measures to prevent deterioration from the effects of water. Cleaning back gutters and downpipes, maintaining the integrity of the roof and renewing the exterior wall coatings in particular should be part of any routine maintenance programme (Harrison, H. W. & de Vekey, R. C.). Vegetation growth should be removed, such as ivy and other climbers, though there is some evidence that vegetation can provide cover for walls from water ingress and frost.

There is no clear published guidance on the required frequency of the above maintenance schedule. It is advisable that the occupants of the house should include maintenance cleaning and vegetation cutting-back as part of the regular home and gardening work (Standards Australia, 2002). Roof leakage should be corrected as soon as it is detected and any defective pipes should be replaced immediately (Hammond, 1973).

Under favourable conditions (proper preparation of the wall surface and good paint application) modern emulsion and oil based paints may protect earth walls between 3 and 5 years (Vale, 1973; Houben et al., 1994; Middleton 1952). Breathable lime renders have provided protection to rammed earth and cob walls for many years. Regular painting and repair of render coats will extend life of building considerably. Cement based renders are generally not recommended on natural earth walls, not least because of problems with water retention following cracking. In recent years there have been a number of cob building failures arising from this problem (Keefe et al, 2001). Mud renders, rarely used externally in UK earth building, provide some protection but typically require regular (annual) repair following the rainy season cycle in sub-tropical and tropical regions of the world, unless further protected by paint or other materials. Where transparent coatings, such as sodium silicate, which maintain the appearance of rammed earth, are preferred to

Maintenance & Repairs 9

paints or renders care should be taken over time to maintain them as damage to transparent surfaces are harder to notice than to those of coloured appearance.

There are no generally adopted guidelines on the routine maintenance of rammed earth structures. Obviously these depend very much on the nature and complexity of the structure, but for simple one- to two-storey residential buildings, some guidance is provided in the Australian earth building handbook (Standards Australia, 2002) and summarised in Table 9.1 below.

Table 9.1: Maintenance of earth buildings (Standards Australia, 2002)

Item	Check
Control Joints	Condition of sealant; cleanliness of joints; vegetation
Damp proofing/flashing	Integrity of damp proofing and flashing along base course
Door/window frames	Loosening of door and window frame anchorage; evidence of moisture penetration; condition of sealant; difficulty opening (evidence of building settlement)
Drainage	Leaking drains, downpipes, guttering; blockage of drains and evidence of overflow; ponding of rainwater; integrity of splash-back courses
Earth Floors	Wearing of surface; damage to protective coating; damp
Footings	Damp; settlement (cracking of footing/ground slab); scour of foundation material; evidence of roots undermining foundation
Metallic Fixtures	Integrity of fixing connection; evidence of corrosion of metallic fittings; cracking or spalling of wall
Roofs/verandas	Structural integrity; tighten holding down bolts; leaks
Surface coatings	Abrasive damage; cracking; erosion; peeling; spalling; separation
Termites	Evidence of termite and other harmful insect activity; integrity of barrier
Vegetation	Cut-back overgrowth near building; avoid planting large trees close to buildings
Walls	Cracking (shrinkage; settlement; thermal; overload; lintel bearings; services); structural integrity; erosion; damp; weep-holes/ventilation ducts clean

More detailed defect surveys are required when dealing with earth monuments (Hughes, 1983). These consist of:

- a survey to record the structure and identify the problems (production of scaled drawings to show building methods and defects such as cracks, trial pits and rectified photographs); and

Maintenance & Repairs 9

- identification of the cause of the problems (though soil sampling, monitoring, structural and environmental analysis).

Similar detailed approaches have been developed for the historic building conservation of cob buildings (Keefe et al., 2001). However, such detailed surveys should not be required in the context of modern residential buildings.

Although some publications suggest annual intervals (Dayton, 1991; Standards Australia, 2002), it is not yet clear what the frequency of the maintenance inspections should be. Undoubtedly, decay surveys should be carried out following unusually severe weather conditions or in the event of damage caused by impact, traffic vibration or any other cause that can result in severe localised impairment of the structure.

9.1.3 Design

Sympathetic appropriate design has significant role in minimising maintenance. A well designed building with good detailing will require far less maintenance than one designed with other materials in mind. Flat roofs, small overhangs and a general failure to provide protection from rainfall needs to be carefully considered.

9.2 Defects & Repairs

9.2.1 Defects

Defects in rammed earth arising after construction include formwork patterning, mismatch colour patch repairs, colour variation between panels, bolt hole repairs, shrinkage cracking, efflorescent staining and boniness (Standards Australia, 2002). Disagreements between contractors and clients over finish of wall are an increasingly common source of dispute in Australian rammed earth construction. Following construction deterioration of walls may occur from water borne erosion, freeze-thaw deterioration, accidental abrasion, vandalism or impact and vegetation growth.

Defects of earth buildings can assume two main forms: deficiencies of surface coatings; and, structural defects. In the context of this review structural defects are taken as defects to the wall as separate from defects to surface coatings and finishes. Problems to other elements of the building not formed from earth, such as roof or windows, are not considered in this review. If not suitably treated, deficiencies to surface coatings can result in more significant structural deficiencies. It is clearly important to understand the causes of any defects before attempting its repair (Pearson, 1992). If the causes of the defect are not correctly addressed it is most likely that the same problem will reoccur.

Surface defects include (Pearson, 1992):

- cracks;
- flakes;
- blistering;
- peeling;
- loss of adhesion; and
- boniness.

Structural defects include (Pearson, 1992):

- water borne erosion of wall;
- freeze-thaw heave of wall;
- low level erosion at base of wall;
- structural cracking (settlement, overload);
- bulging;
- abrasion damage; and
- rat runs and animal holes.

9.2.2 Repairs

Following survey, repairs on rammed earth buildings may be required to safeguard structural and functional integrity. Alternatively repairs can be required as result of the need for alteration or renovation of a structure. The repair philosophy for buildings of historic importance is one of minimum intervention to ensure long-term stability and optimum performance of the structure without causing physical disruption. The most appropriate way of carrying out repair works is to use the original raw materials, wherever possible.

9.2.2.1 Repair of Surface Coatings

When deficiencies on the surface coating, such as cracks, flaking, peeling, blistering, crazing, bleeding and loss of adhesion, emerge the coating should be repaired either locally or if necessary entirely. Different types of coatings require different repair techniques. In general repairs should follow same general good practice for renders and plasters (Standards Australia, 2002). As a general rule the surface should be dry before the application of the repair. The render material should be compatible with the fabric of the wall. Importantly, uniformity of appearance and surface texture should be maintained.

9.2.2.2 Repair of Structural Defects

Structural defects in earth walls may manifest themselves as tensile cracking, arising from both structural action or material shrinkage, as well as material spalling, bulging, scouring from erosion, and even partial collapse. The main causes of defects include chronic damp, abrasion from general use, poor design, poor construction, poor maintenance, and development of tensile stresses in the wall due to overload, settlement or restrained shrinkage.

(a) Bulging

In old (cob) buildings no attempt should be made to realign leaning or bulging sections of earth walls by the use of hydraulic jacking or leaning sections. Walls should be stabilised as they stand except if unacceptable degree of outward lean has developed (DHBT, 1993).

(b) Shrinkage Cracking and Spalling

In rammed earth walls unsightly shrinkage cracks can be repaired by pointing or filling with dampened soil of similar characteristics (colour, grading, plasticity) to the original. Colour match and bond with the main wall are the main concerns.

(c) Structural Cracking and Underscour

The general advice is that no attempt should be made to repair a structural crack if there is not a reasonable degree of certainty that all movement has ceased. There are two main methods of repairing structural cracks and underscour erosion damage (Pearson, 1992; Standards Australia, 2002):

- by using pre-cast earth blocks with or without reinforcement to form a repair in the earth mortar; and
- by ramming into place new material, with or without reinforcement, temporarily supported by formwork on one face and then cut back the exposed surface to the original line of the wall.

If large cracks have occurred or if sections of the wall have partially collapsed, the main floor beams and roof rafters may need support. Timber posts, masonry or stabilised blockwork pillars can be used to support the end beams, but in any case it is advisable to get advice from a structural engineer prior to any intervention (DHBT, 1993).

9.2.3 Renovation of Old Earth Buildings

When renovating an earth building a careful record of its initial condition is required in advance of further considerations such as expected new use, the replacement or repair of any structural elements and the remaining building features such as doors and windows. Further considerations in line with principles of architectural conservation are required when during the restoration of a building of historic interest or importance. McHenry (1984) proposes that the following should be considered when restoring or renovating an earthen structure:

- Historical investigation (archival resources; make measured drawings);
- Determine problems (prevent structural failure);
- Dry out the structure
- Determine future utilisation possibilities (alternative uses, viable economic projections);
- Select appropriate details; and
- Sequence schedule of priorities.

9.3 Conclusions

Maintenance of a rammed earth building is not necessarily any more onerous than the maintenance of any other traditionally-built dwellings. However, absence of regular maintenance can be more damaging in earthen structures than in other building types. Although no clear recommendations exist, it is important that a suitable maintenance schedule for rammed earth structures is required and be sustained.

In broad terms, repairs of earthen structures are required as a result of poor maintenance, poor construction or poor detailing. Any repairs require careful planning and for structural repairs the advice of a suitably qualified and suitably experienced structural engineer should always be sought.

UK Rammed Earth Projects Review 10

10.1 Scope

Between late April and May 2003 the project team visited a number of historic and recent rammed earth and chalk building projects in the UK. A number of people associated with these projects were interviewed either in person or by phone. In addition to the projects outlined below, Ryton Workshop (built 1995), Earth Centre, Doncaster (planned but never built) and Bird-in-Bush project (to be built later in 2003) were also considered. The main findings are summarised in this chapter.

10.2 Project Descriptions

10.2.1 Rammed Chalk Buildings, Hampshire

<i>Name</i>	Approximately 100 rammed chalk buildings.
<i>Location</i>	Andover, Winchester and other towns and villages in Hampshire.
<i>Built</i>	Nineteenth century.
<i>Use</i>	Mainly residential properties, but some converted to schools and other public buildings.
<i>Type</i>	Loadbearing and non-loadbearing rammed chalk; internal and external walls.
<i>Interviewees</i>	Gordon Pearson (Building surveyor and conservator)



Figure 10.1: Five storey rammed chalk building in Winchester, Hampshire

10.2.2 Amesbury Houses, Wiltshire

<i>Name</i>	Holdes Road and Ratfyn Road, Amesbury
<i>Location</i>	Amesbury, Wiltshire
<i>Built</i>	Between 1919 and 1921
<i>Use</i>	Residential properties
<i>Type</i>	Loadbearing rammed chalk; external walls

UK Rammed Earth Projects Review 10

Interviewees Mr & Mrs Adcock (Occupants of 24 Holders Rd property)
Mrs S Cox (Occupant of 26 Holders Rd property)
Mrs S Farley (Occupant of 65 Holders Rd property)
Mr F Westmoreland (Occupant of 42 Holders Rd property)
Mr M H Roberts (Occupants of 124 Holders Rd property)
Mr & Mrs Kinder (Occupants of Millmead property, Ratfyn Rd)
Mr I West (Occupant of Avon Meads property, Ratfyn Rd)



Figure 10.2: Residential rammed chalk property in Amesbury, Wiltshire

10.2.3 Holly Howe/Warburg Nature Reserve, Oxfordshire

Name Holly Howe
Location Warburg Nature Reserve, Oxfordshire
Built 1992
Use Fruit/vegetable store
Type Cement stabilised and natural loadbearing rammed earth; external and internal walls
Interviewees Nigel Phillips (Owner/self builder)
Andy Simmonds and Adele Mills (Consultants)



Figure 10.3: Fruit/vegetable store in Warburg Nature Reserve, Oxfordshire

UK Rammed Earth Projects Review 10

10.2.4 Dragons Retreat, Devon

<u>Name</u>	Dragons Retreat (formerly known as West Lake Brake)
<u>Location</u>	Plymouth, Devon
<u>Built</u>	1997
<u>Use</u>	Residential
<u>Type</u>	Cement stabilised rammed earth; loadbearing internal and non-load bearing external walls
<u>Interviewees</u>	Mr & Mrs Francis (Occupants) David Sheppard (Architect)



Figure 10.4: Dragons Retreat, Plymouth, Devon

10.2.5 Visitors Centre, Eden Project, Cornwall

<u>Name</u>	Visitors Centre/Eden Project
<u>Location</u>	St Austell, Cornwall
<u>Built</u>	1999
<u>Use</u>	Public visitors Centre
<u>Type</u>	Natural rammed earth; non-loadbearing external wall
<u>Interviewees</u>	Neal Barnes (Facilities manager, Eden Project) Jolyon Brewis (Architect, Grimshaw Architects) Rowland Keable (Contractor)



Figure 10.5: Visitors Centre, Eden Project, Cornwall

10.2.6

Woodley Park Centre for Sports & Arts, Lancashire

<i>Name</i>	Woodley Park Centre for Sports & Arts
<i>Location</i>	Skelmersdale, Lancashire
<i>Built</i>	1999
<i>Use</i>	Sports hall
<i>Type</i>	Cement stabilised and natural rammed earth; non-loadbearing external walls
<i>Interviewees</i>	John Renwick (Project manager; Designer) Rowland Keable (Consultant)



Figure 10.6: Woodley Park Centre for Sports & Arts, Lancashire

UK Rammed Earth Projects Review 10

10.2.7 AtEIC Building/Centre for Alternative Technology, Powys

<u>Name</u>	AtEIC Building/Centre for Alternative Technology
<u>Location</u>	Machynlleth, Powys
<u>Built</u>	2000
<u>Use</u>	Visitors Centre
<u>Type</u>	Natural rammed earth, loadbearing internal walls and columns.
<u>Interviewees</u>	Cindy Harris (Project manager) Pat Borer (Architect) Andy Simmonds and Adele Mills (Contractors/consultants)



Figure 10.7: AtEIC Building/Centre for Alternative Technology, Machynlleth, Powys

10.2.8 The Stables, Northamptonshire

<u>Name</u>	The Stables
<u>Location</u>	Ashley, Northamptonshire
<u>Built</u>	2001
<u>Use</u>	Stables
<u>Type</u>	Cement stabilised rammed earth; loadbearing external and internal walls
<u>Interviewees</u>	Bill Swaney (Owner/builder)

UK Rammed Earth Projects Review 10



Figure 10.8: The Stables/The Manor, Northamptonshire

10.2.9 Jasmine Cottage, Norfolk

<u>Name</u>	Jasmine Cottage
<u>Location</u>	Blakeney, Norfolk
<u>Built</u>	2001
<u>Use</u>	Residential property
<u>Type</u>	Cement stabilised rammed earth; loadbearing external and internal walls
<u>Interviewees</u>	Marion & Francis Chalmers (Clients) Tim Hewitt (Builder) Colin Williams (Building Control Officer, North Norfolk District Council)



Figure 10.9: Jasmine Cottage, Norfolk (photo: Francis Chalmers)

UK Rammed Earth Projects Review 10

10.2.10 Sutton Courtenay Environmental Education Centre, Oxfordshire

<u>Name</u>	Sutton Courtenay Environmental Education Centre
<u>Location</u>	Didcot, Oxfordshire
<u>Built</u>	2002
<u>Use</u>	Environmental Education Centre
<u>Type</u>	Natural pressed earth blocks, load bearing internal wall
<u>Interviewees</u>	Kate Cheng (Berkshire, Buckinghamshire, Oxfordshire Wildlife Trust) Andy Simmonds and Adele Mills (Architects and Consultants)



Figure 10.10: Sutton Courtenay Environmental Education Centre, Oxfordshire

10.2.11 Sheepdrove Organic Farm, Berkshire

<u>Name</u>	Sheepdrove Organic Farm
<u>Location</u>	Lambourn, Berkshire
<u>Built</u>	2003
<u>Use</u>	Education and conference Centre
<u>Type</u>	Rammed chalk, non-loadbearing internal wall
<u>Interviewees</u>	Mark Lovell (Structural engineer)



Figure 10.11: Sheepdrove Organic Farm, Berkshire

10.3 Summary of interviews

UK Rammed Earth Projects Review 10

The following sections broadly summarise findings from the project review interviews and visits. They are not intended as a critique of any specific project but as an overview of past and current practice in UK rammed earth and chalk construction.

10.3.1 Codes of practice

No standard specifically for rammed earth construction was used during the design of any of the examined projects. Some guidance was sought from current literature, including Middleton (1992), Houben & Guillaud (1994), Keable (1994) and King (1996).

10.3.2 Materials

Though it is widely recognised that material quality is critical to the success of rammed earth buildings, material testing and appraisal procedures for various projects have varied widely. The most comprehensive set of testing was carried out for the AtEIC Building, at the University of Plymouth by David Clark, included grading curves, compressive strength, and plastic and liquid limit tests. The benefit of these tests is certainly now reflected in the high quality of the walls at CAT. Similar testing was carried out for the Eden Project and Sheepdrove. However, the cost of material testing has been seen as a deterrent to some designers and clients. In other cases material selection was undertaken by the earth builder using experience and some trial compaction tests. Use of cement stabilisation in some of these projects has undoubtedly reduced the risk associated with material selection. No accelerated erosion testing was carried out for any of the examined projects.

Materials used in two of the recent projects were sourced from in-situ excavations, Eden Project and Sheepdrove, whereas in the remaining buildings materials were imported from quarry sites up to 40 miles from the project. Materials have often been blended with sand or clay, as appropriate, to ensure an ideal mix. In general materials have been screened to at least 20 mm down, though at the Eden Project fragments up to small boulder size (100-200 mm) were included internally in the walls.

Cement stabilisation has been used in five of the recent projects. Reasons for using cement were varied, but largely centred on improving durability and strength combined with reducing risk. In some projects, such as Dragons Retreat, exposure to wind-driven rainfall made cement stabilisation a necessity. The percentage of Portland cement used varied from 2%-3% in the case of Holly Howe, to 5%-10% in some of the wall sections of the Woodley Park Centre. In the case of rammed chalk, the chalk is typically rammed in its natural state following excavation, pulverising and screening. At Sheepdrove 2% granulated ground blast furnace slag was added to the chalk to improve strength and durability.

Though rammed earth has been widely used in external walling, recent projects have largely recognised the poor thermal insulating properties of rammed earth. For design, values have been found from existing literature (Houben & Guillaud, 1994). For Jasmine Cottage the thermal conductivity values were soil were taken from CIBSE guide and applied to the rammed earth walls.

UK Rammed Earth Projects Review 10

The fire resistance properties of earth were not considered a concern in any of the projects examined. In the Eden Project flame spread was considered and rammed earth elements were considered to have beneficial properties. Similarly acoustic properties of rammed earth were generally considered to be adequate without extensive research or testing, though problems with noise reflectance in public buildings has been noticed.

10.3.3 Structural design

Procedures used in the design of unreinforced masonry have been used to check rammed earth walls, or alternatively rammed earth has been considered as a low strength mass concrete. Typically design is governed by a minimum compressive strength specification for the material and limiting wall slenderness. Thermal, acoustic, fire resistance and construction requirements generally govern minimum wall thickness.

Slenderness ratios (ratio of wall or column height to thickness) of loadbearing walls in new rammed earth projects visited varied between 4.6 and 8.9. Only slightly more slender non-loadbearing wall panels ranged between 8 and 10. The thickness of load-bearing walls varied from 310 mm to 500 mm, whereas thickness of non-loadbearing walls varied from 340mm to 550mm. The walls in the Hampshire and Amesbury properties typically vary in thickness from 20 inches (508mm) in lower storeys to 12 inches (~305mm) for the top storeys; wall thicknesses of five-storey buildings in Winchester are not available.

For structural design material compressive strength were either assumed and then specified on the basis of current literature (Jasmine Cottage) or first established by experimentation (AtEIC) and used in structural checks. In Jasmine Cottage, for example, a design compressive strength of 0.22 N/mm^2 was assumed for structural design, then applying a factor of safety of 24 (Houben & Guillaud, 1994) a minimum material compressive strength of 6 N/mm^2 was specified.

10.3.4 Architectural design & detailing

A large number of historic projects visited were residential, though all but two of the modern rammed earth buildings visited have been non-residential. The historic properties were architect designed and specialist contractor built. Though mostly architect designed recent projects in contrast have been built by inexperienced volunteer labour as well as by experienced specialist contractors.

Motives for using rammed earth are similarly varied. Rammed chalk was introduced into Hampshire in late 18th century by architects keen demonstrate architectural advantages of the technique (Pearson, 1992). A number of houses in Winchester were built using chalk reclaimed from railway excavations. The Amesbury houses were built after WWI as experimental demonstrations of using low cost local materials (Williams-Ellis, 1919). The environmental benefits of earth construction have been primary motivating factors in selection of rammed earth for all modern projects.

Majority of buildings visited were either single or two-storey construction, though inspections included two five-storey loadbearing rammed chalk houses in Winchester (figure 10.1). Rammed earth is used both as external and internal walling. In historic buildings the use of rammed chalk would seem to have had little impact on architectural

UK Rammed Earth Projects Review 10

layout. In modern projects the primary issues raised during the review with external walling were durability and thermal insulation. Internal walls, protected from weathering after completion of construction, have been used to provide thermal mass to otherwise lightweight timber frame buildings as well as being loadbearing elements. In two projects, Woodley Park and Jasmine Cottage, the architecture followed Sthapatya Veda design principles.

Openings in buildings investigated reflect the range of solutions adopted. Embedded steel tee-sections or reinforcing bars were used in The Stables, whereas solid timber sections were used in Jasmine Cottage. Bearings for lintels were raised during interviews as a concern, with a minimum bearing of 200 mm considered necessary in cement stabilised rammed earth. In both Holly Howe and Woodley Park Centre arched openings were the preferred option.

Fixings to rammed earth walls were generally considered a potential problem. For light domestic applications (shelving, pictures) the strength of rammed earth is considered sufficient. However drilling through rammed earth can be a problem. At Amesbury battened timber boarding has been provided in some houses as a wall face for fixings. For heavier fixings, such as the glass plates at AtEIC, direct support from the ground has been used. For fixing window and door frames, raw plugs seem to be an acceptable solution. For fixing the roof timber wall plates or concrete beams have been provided on top of the rammed earth wall. At Dragons Retreat the wall plate is tied through the wall to the footing using steel bars.

In the Hampshire and Amesbury houses there is usually a plinth splash barrier but not always a damp proof course. In all modern rammed earth buildings however, a damp proof course is considered an essential part of the design and even double damp proof courses have been used. Plinths are typically concrete or brickwork. Preferential erosion has been observed at the base of rammed earth walls at both the Eden Project and Woodley Park Centre, where walls rest directly on damp proofing on top of the plinths.

Eaves details also vary considerably. In the rammed earth buildings found in Hampshire the walls are protected by thick coats of hydraulic lime render. Similarly at Amesbury walls are protected by rendering or lime wash coats. Consequently, in both cases roof eaves are modest and provide little protection to wind-driven rain. At the Eden Project a large eaves projection protects the wall.

Historic Hampshire and Amesbury rammed earth houses have services, including in some cases plumbing, incorporated within the wall, though mostly services were fixed externally at a later stage. In many of the modern buildings electrical conduit has been rammed into the walls, though plumbing has been external.

To improve thermal insulation of external rammed earth walls two solutions have been used in recent projects. At The Stables 50 mm thick rigid foam insulation was incorporated within a 450 mm thick wall section during construction. Ties were placed through insulation to connect external and internal skins of the wall. This trial was considered successful in construction, though subsequent thermal performance of the wall has not been monitored. At Jasmine Cottage the U-value of external walls was reduced sufficiently to achieve a U value of 0.7 by using an external thermal insulating

UK Rammed Earth Projects Review 10

render coat. The 60 mm thick render is lime based and incorporates pumice stone aggregate.

A variety of approaches have been adopted in improving the durability of rammed earth. Cement stabilisation is of course one approach that is tried and tested. However, for many designers and builders cement stabilisation is not acceptable because of the environmental impact of cement production and the fundamental changes stabilisation has on the earth. In contrast sodium silicate has been used at the Eden Project to improve surface durability. In many historic rammed chalk buildings the walls are rendered with lime. This approach is to be adopted at Woodley Park Centre. In some rammed chalk buildings in Hampshire an external skin of brickwork has also been used.

Internal surfaces of the traditional rammed chalk houses were lime rendered. At the Woodley Park Centre internal surfaces are rendered with natural clay plaster to protect surfaces from sports activities. However, in most recent rammed earth buildings internal surfaces have been left uncovered, though clear treatments to improve durability include natural oils (AtEIC Building), sodium silicate (Eden Project), glass screens (AtEIC Building), diluted carnauba wax (Jasmine Cottage), and a stabilising chemical solution (Sheepdrove).

10.3.5 Construction

Professional contractors built all but two of the projects examined. Holly Howe was built by the owner and his family, following advice from Simmonds Mills. The Woodley Park Centre was built by community volunteers, following the advice of In-situ Rammed Earth.

Almost everybody interviewed that has been involved in the building process of a rammed earth structure acknowledged that construction process is very much dependent on weather conditions. Dry storage of materials and protection of formwork and fresh walls from rainfall is essential. Storage and movement of large quantities of materials on site needs to be carefully considered in site organisation. Because of these issues rammed earth works have generally been on the critical path of project work schedules.

Setting, aligning and stripping down the formwork was accepted as the most time-consuming task of the building process, accounting for up to 80% of the time on site, though more typically it was considered to be around 50-60%. Selection of a suitable formwork system that is light to handle, easy and quick to erect and align, does not overly impede filling and compaction, has sufficient strength and stiffness, and is safe and easy to dismantle is critical to the rate of working and overall success of the work. Features such as tapering wall sections, corners, openings and in-plan curvature all influence rate of which formwork can be used.

There are clearly many factors influencing rate of productivity and costs of rammed earth works. Quoted productivity rates vary from less than 1m³/day for the AtEIC Building and the Woodley Park Centre, which was community-built, up to 3m³/day for the Eden project for a gang of 3-5 people. Similarly costs of wall construction vary significantly as well. Rates range between £80 to around £250/m² for a 300 mm thick wall.

UK Rammed Earth Projects Review 10

In the majority of cases formwork was built vertically as the compaction proceeded; at Sheepdrove the contractor built each formwork panel to full height and the chalk was compacted from the top. The formwork was usually based on concrete forms, comprising of a plywood face with steel soldiers, walers and steel through-ties. However, in the AtEIC Building the through ties were replaced with external clamps based on a system proposed by David Easton (1994). The size of the panels depended on the size of the wall and varied in length from 1800mm to 3000mm. Minimising the number of ties in the formwork was an important factor determining efficiency of the compaction process. Form faces were generally untreated, though release agents have been used in some projects, such as Holly Howe.

While in the traditional rammed chalk houses manual ramming was the only method used, in modern rammed earth construction pneumatic ramming seems to be the dominant trend, except in corners and wall junctions where it is difficult to operate the pneumatic head. However there were still a few reported cases where hand ramming was more extensively used (Holly Howe, Sheepdrove). Some concern has been expressed about the health and safety aspects of compaction, including risk of white finger when using pneumatic rammers. For this reason in the AtEIC Building specially designed gloves, that reduce the risk of white finger, were specified.

10.3.6 Quality Control

The most common problem influencing quality of construction encountered on site was keeping the earth dry prior to, during and following construction. The raw earth was therefore often protected under temporary covers. In some projects, such as the Eden Project, Woodley Park Centre and AtEIC Building, wall construction proceeded after completion of the roof, which thus provided protection for the walls from rainfall. The drop test, used for checking the moisture content at compaction, was widely used, though more experienced builders judge moisture content by observation and feel alone.

The principal means of mixing soil, mainly with water but also with cement, in most examined projects was by a concrete mixer. However, material balling was a common problem. In keeping with Australian practice materials in The Stables project were successfully mixed using of a 'bobcat' front-end loader.

Where inexperienced personnel undertook wall compaction the quality of wall construction often suffered. This is perhaps to be expected. Therefore, specifications and methods of working for rammed earth works on site are essential to achieve highest possible quality rammed earth construction.

10.3.7 Foundations

The houses in Hampshire and Amesbury mostly have shallow foundations of chalk and flint or brickwork. Foundations for modern earth buildings are either pad or strip footings made out of concrete. The only exception is the AtEIC Building, which has a limecrete foundation. Generally the design of foundations for the rammed earth projects examined was not found to be significantly different from other forms, such as masonry, with the exception of raised plinths for the external earth walls.

UK Rammed Earth Projects Review 10

10.3.8 Maintenance and Repair

For the most part recent rammed earth projects had not warranted any significant maintenance and walls are performing well. In some projects small repairs, such as patching tie holes and boniness, have been required to walls immediately after construction. However, this is generally to be expected and common practice. Matching repairs with original construction is a common problem. Differential rates of drying caused one of the wall panels at AtEIC to bow, but this was corrected by jacking and correcting the uneven drying. Where maintenance procedures have been specified, such as regular application of a (sodium silicate) surface spray, these have often not been undertaken by the clients.

The traditional rammed chalk houses of Amesbury were the most useful for obtaining maintenance information. During the more than 80 years of history of these buildings there have been some alterations. At two properties extensions to the original houses had been added using more conventional building materials. New door openings were generally placed at existing windows, avoiding the need to add new lintels. Generally extensions should be structurally independent of the original fabric and incorporate movement joints between new and old. No significant problems were identified with extensions to the properties visited.

Renders to Hampshire chalk buildings and Amesbury houses are largely the original lime based coatings. Where subsequently cement based repairs have been applied these have often failed due to usual problems of moisture build up behind. Walls originally lime washed, such as the property at 24 Holders Road, Amesbury, now successfully use 'sandtex' external paint applied every 5-7 years. The importance of providing vapour permeability was often recognised by owners of these properties.

10.3.9 Planning & Building Control

In terms obtaining planning permission only some incidental problems were encountered, not relating to the nature of the earthen elements but more to the local restriction in the areas where the projects were built.

For building control the most common concerns raised related to thermal insulation and compressive strength. No external rammed earth wall buildings visited were assessed under new Part L regulations in the 2002 edition of the building regulations. Some building control authorities were happy to accept the rammed earth strength characteristics as proposed by a suitably qualified engineer or following laboratory testing. In other instances authorities required more rigorous testing of materials prepared on-site. For example, at the Jasmine cottage North Norfolk District Council building control required two cubes for every 1.5m³ of earth wall, with 6 out of 8 cubes tested achieving 100% of the ultimate design strength (6 N/mm²), 7 out of 8 not less than 75% and none less than 50% of the specified design strength.

10.3.10 Financial aspects

It was not possible to obtain detailed information on financial issues relating to private ownership of residential properties. However, the interviewees raised no specific

UK Rammed Earth Projects Review 10

problems with regard to mortgaging or financing. In new build projects approval by a suitably qualified structural engineer was sufficient for some financial companies. For more public projects, such as AtEIC and Eden Project, including rammed earth was believed to enhance the successful funding applications for these projects.

Obtaining buildings insurance for existing rammed earth and chalk buildings was generally not considered a problem and premiums did not appear to be higher than for comparable, more conventional, buildings. However, recent instances with cob and traditional chalk buildings where insurance companies have not paid out following flood damage highlight a need for occupants of non-conventional buildings to check policies with their insurers.

10.3.11 Other observations

Most of the observations of the residents of the rammed earth or chalk structures agree that earth, including chalk, creates a very pleasant indoor environment, warm in the winter and cool in the summer. Some of the residents of Amesbury were not aware at the time they bought their properties of the nature of the building while for others the earthen element of the structure was a positive factor in their selection.

It was the view of most of the interviewees that regardless the advantages of rammed earth construction and the proven robustness of the material, the technique is not well established in the UK due to the conservatism of the construction industry and the longer construction period and higher cost required. It was also felt that the main reasons for the high cost was the formwork system, the labour intensity of the technique and the difficulty in evaluating and sourcing the right material. Therefore any future application should target either the environmentally sensitive client or the one that enjoys the earthen architectural appeal.

The wet and potentially frosty weather was also another factor that was felt to jeopardise the use of rammed earth in the UK. This, combined with the high thermal transmittance values of rammed earth, lead to some suggestions that the use of rammed earth should be limited to internal elements. Prefabricated pressed or rammed blocks, as used at Sutton Courtney, are considered by some to be more suitable for UK practice because of weather problems, but do of course provide a completely different natural finish.

At present there are at least a further nine UK rammed earth projects currently under construction or in various stages of planning. Four of these are specifically residential projects.

11.1 Final Conclusions

The conclusions drawn out of this review are organised and presented in the next sections based on the various thematic unities included in the report.

11.2 National Codes

- Currently there are no UK national standards or reference documents for rammed earth construction.
- National documents for rammed earth have been published in a number of other countries. These cover various aspects, including advice on materials selection, structural design, construction and maintenance. Though developed in countries where climate and building culture often differs significantly from the UK, the reference documents form an important input into UK guidance documents as they express the current state-of-the-art.

11.3 Materials

- Characteristics of soils used for rammed earth may be appraised using a variety of physical characteristics, including colour, grading and plasticity.
- Recommendations for soil grading vary between current reference documents, though there is broad general agreement.
- Although unsuitable soils can be readily identified, standard soil characterisation tests, such as grading, are not reliable to establish the suitability of a soil for rammed earth.
- Physical characteristics of rammed earth may be measured in terms of its dry density, strength (compressive, tensile, shear), durability, shrinkage, surface finish and thermal properties.
- Durability of rammed earth is assessed by a variety of accelerated erosion tests, though there remains little correlative data between tests and field performance.
- Dry density is often determined by Proctor compaction tests though actual compaction practice often differs.
- Physical properties are strongly related to material density.
- Structural characteristics of rammed earth walls in compression and flexure has not been widely investigated.
- Few published results for thermal properties of rammed earth.
- Cement stabilisation is widely used in USA and Australia to improve strength and durability. Cement stabilisation is seen as reducing risks associated with using rammed earth. Other forms of stabiliser, such as lime and natural fibres, are less widely used in rammed earth.
- In summary, soils suitable for rammed earth houses are broad and include sands with sufficient clay and silt, clayey silts, clayey gravels and gravel-sand-clay mixtures.

11.4 Structural Design

- Structural design guidance for rammed earth walls largely follow procedures developed for loadbearing masonry.

Conclusions 11

- In many low rise examples, rammed earth walls are designed on the basis of proportions, such as slenderness ratio and/or minimum thickness, without requirement for more rigorous design checks.

11.5 Architectural Design & Detailing

- Traditionally rammed earth has been used for both external and internal walls. However, regulatory and design requirements for thermal insulation make external rammed earth walls difficult to build without excessive thickness or additional insulation. Using rammed earth internally for thermal mass and protecting from water borne deterioration is an increasingly common design solution.
- Openings may be formed in a variety of ways, including arched openings, timber lintels, concrete lintels and steel lintels.
- Structural and non-structural fixings are either fixed directly to rammed earth or timber elements embedded into the rammed earth during construction. Mechanical raw bolt connections are widely used in both natural and cement stabilised rammed earth.
- Suspended floors and roofs supported on wall plates or ring beams.
- Electrical services are commonly buried in conduit in rammed earth during construction.
- Detailing, such as sills, reflect low strength and low water resistance of rammed earth. Natural rammed earth in particular needs to be protected from water borne erosion by adequate roof overhang and wall plinths.
- Good detailing inhibits deterioration and minimises maintenance costs.

11.6 Construction

- Soil should be carefully prepared before construction. Processes following extraction include screening to remove oversized particles, pulverisation, drying and mixing.
- Rammed earth should be compacted at its optimum moisture content. Keeping soil dry during wet weather is a very important consideration.
- Formwork should have sufficient strength and stiffness.
- The erection, alignment, striking, removing, and cleaning of formwork comprises significant labour elements of rammed earth construction.
- A variety of formwork systems have been used in the UK. Plywood faced with timber or metal soldiers and walers and using metal through ties is a common system.
- Compaction methods include manual, pneumatic, vibrating plate and sheepsfoot roller.
- Soil uniformity is important to the finished quality of rammed earth.

11.7 Quality Control

- Material selection is important to the finished quality of rammed earth.
- Weather conditions during and following construction are important to quality of rammed earth. Materials should be placed at optimum moisture content and protected from rainfall during drying.

Conclusions 11

- Published tolerances for rammed earth generally exceed those of similar construction methods such as masonry.
- Quality of in-situ rammed earth is measured by strength (cylinder or cube compressive strength), dry density, surface hardness and finish (colour, texture, friability).
- Where rammed earth has become more established, such as Australia, disagreement between client and contractor over the finished quality of walls has become increasingly common in recent years.

11.8 Foundations

- Rammed earth walls are typically built on shallow strip footings or stiffened ground slabs.
- Walls are generally built on raised plinths.
- A variety of damp proofing materials, including slate, plastic membranes and bituminous paints have been used successfully. Damp proof courses should be able to withstand the impact of compaction and shrinkage without damage.
- Damp proofing should usually be a minimum 150 mm above ground level.
- Footings are mainly concrete, though may also be limecrete and masonry.
- The ground immediately adjacent to the base of a rammed earth wall should be well drained and footings protected from water infiltration. Provision of surface and subsurface drains together with damp-proof coursing is generally essential.

11.9 Maintenance & Repairs

- Water is a major agent of decay in rammed earth buildings. Maintenance should seek to protect rammed earth from water borne deterioration.
- Repairs to earth buildings are generally required as a result of poor maintenance, poor construction or poor detailing.
- Durability may be improved by application of protective coatings, such as renders, lime washes, paints, sodium silicate and waxes.
- Defects in rammed earth include boniness, cracking, and surface erosion from water and abrasion.
- Major repairs require careful planning and structural repairs should only be undertaken following advice of a suitably qualified engineer.

11.10 Project Review Key Points

- The lack of UK design and construction guidance notes was apparent in the review of recent rammed earth buildings.
- There are a large number of successful historic rammed earth and chalk buildings in the UK and growing number of modern buildings as well.
- Rammed earth walls are used for both loadbearing and non-loadbearing walls and both externally and internally.
- Concerns over weather conditions, especially keeping material at a suitable moisture content prior to compaction and whilst in formwork, has been recognised as major factor to success of rammed earth in UK.

Conclusions 11

- Organisation of the site, and in particular the formwork, is key to the success of rammed earth projects.
- Erosion protection is important consideration in the design of rammed earth walls.
- Poor insulation properties of rammed earth have been addressed in recent projects by using an external insulating render or incorporating internal rigid foam insulation. The effectiveness of these solutions is, however, yet to be established.
- A variety of quality control measures have been used in recent rammed earth projects, including regular cube testing for compressive strength to no proscribed testing at all.
- The finished cost of rammed earth walling in the UK depends on a variety of factors, but typically ranges between £80 and £250/m² for a 300 mm thick wall. This cost is competitive compared to quality masonry and other walling finishes.
- In recent UK projects no significant problems were encountered with building control in the use of rammed earth. However, in the future external rammed earth walling is likely to require additional (external) insulation to meet recent building regulation requirements for thermal transmittance.

References

- ACI Materials Journal Committee Report, State-of-the-art Report on Soil Cement, *ACI Materials Journal*. July-August 1990, 395-417.
- Adam, E. A. and Jones P. J. Thermophysical Properties of Stabilised Soil Building Blocks. *Building and Environment*. 1995, Vol. 30 No. 2, 245-253.
- Alley, P. J. Rammed Earth Construction, *New Zealand Engineering*, June 10 1948, 582.
- AS 1720.1-1997, Australian Standard. *Timber Structures, Part 1: Design Methods*. Standards Australia, Sydney, Australia.
- Berglund, M. Rammed-Earth Portfolio; New forming techniques make houses competitive, but hardly dirt cheap. *Fine Homebuilding*. August/September 1986, 35-
- Bofinger, H. E. *The measurements of the tensile properties of soil-cement*. Berkshire: Road Research Laboratory, Ministry of Transport, 1970. RRL Report LR 365.
- Bryan, A. J. Soil/Cement as a Walling Material – II. Some Measures of Durability. *Building and Environment*. 1988, Vol. 23 No. 4, 331-336.
- BS 5628-3:2001. *Code of practice for use of masonry-Part 3: Materials and components, design and workmanship*. British Standard Institution.
- BS EN ISO 8402: 1995. *Quality management and quality assurance – Vocabulary*. British Standards Institution.
- Building with Earth in Scotland; Innovative Design and Sustainability, 2001, Scottish Executive Central Research Unit. The Stationery Office Ltd., UK.
- Centre for Alternative Technology, 2000, *AtEIC. Autonomous Environmental Information Centre*. Factsheet, Centre for Alternative Technology Publications, Machynlleth, UK.
- CRA Terre, 1982. Recommendations pour la conception des bâtiments du Village Terre. Plan Construction/AGRA.
- Crowley, M. Quality Control for Earth Structures. *Australian Institute of Building Papers*. 1997, 8, 109-118.
- CSIRO Division of Building, Construction and Engineering, 1996, Building Technology File 12, *Earth Wall Construction*. CSIRO Australia, North Ryde, Australia.
- CSIRO Division of Building, Construction and Engineering, 1996, Building Technology File 13, *Pisé (Rammed Earth) Construction*. CSIRO Australia, North Ryde, Australia.
- Dayton, L. Saving mud monuments, *New Scientist*, 25 May 1991, pp. 38-42.
- Deeks, A., 1998, Design Criteria for Reinforced Stabilised Earth Structures, Thesis submitted for the degree of BSc, University of Western Australia, Crawley, Australia.
- Devon Historic Building Trust, 1993, *The Cob Buildings of Devon 2: Repair and Maintenance*. DHBT, Devon, UK.

References

Earth Building Association of Australia, 2001, *Earth Building Book. Draft for Comment*. Draft Code 05/01. Earth Building Association of Australia, Wangaratta, Australia.

Easton, D., 1996, *The Rammed Earth House*. Chelsea Green Publications Company, Vermont, USA.

Gooding, D. E. M. *Soil Testing for Soil-Cement Block Preparation*. Coventry: Development Technology Unit, School of Engineering, University of Warwick, 1993. Working Paper No. 38.

Hammond, A. A. Prolonging the life of earth building in the tropics, *Building Research and Practice*. 1973, pp. 154-163.

Harrison, H. W., de Vekey, R. C. BRE Building Elements; Walls, windows and doors; Performance, diagnosis, maintenance, repair and the avoidance of defects. Building Research Establishment, Watford, UK.

Houben, H. and Guillaud H., 1994, *Earth Construction, A comprehensive Guide*. Intermediate Technology Publications, London, UK.

Hughes, R. Material and Structural Behaviour of soil constructed walls. *Momentum*. 1983, pp. 175-188.

ICOMOS/UK & English Heritage, 2000, *Terra Britannica*, James & James (Science Publishers) Ltd, London, UK.

Jaggard, W. R., 1921, *Experimental Cottages; A report on the work of the Department at Amesbury, Wiltshire*, HMSO: Department of Scientific and Industrial Research, London, UK.

Kapfinger, O., 2001, *Martin Rauch: Rammed Earth | Lehm und Architektur | Terra cruda*. Birkhäuser, Basel, Switzerland.

Keable, J., 1996, *Rammed Earth Structures. A code of Practice*. Intermediate Technology Publications, London, UK.

Keefe, L., Watson, L. and Griffiths, R. A proposed diagnostic survey procedure for cob walls. *Proceeding of the Institution of Civil Engineers Structures and Buildings*. February 2001, 1, 57-65.

King, B. P. E., 1996, *Buildings of Earth and Straw. Structural Design for Rammed Earth and Straw Bale Architecture*. Ecological Design Press, Sausalito, California, USA.

Kornouchow, M. 1933. Investigations on the strength and stability of eccentrically loaded pisé de terre walls. Symposium in memory of Kost Kostyovitch Siminsky Academy of Science of the Ukrainian S.S.R. Institute of Applied Mechanics, Kiev. (in Ukrainian)

Lehmbau Regeln. Begriffe; Baustoffe; Bauteile., 1999, Friedr. Vieweg & Sohn Verlagsgesellschaft mbH, Braunschweig/Wiesbaden, Germany.

Lilley, D.M. and Robinson, J., 1995. Ultimate strength of rammed earth walls with openings. *Proc. Instn. Civ. Engrs, Structures and Buildings*, 100, 278-287.

References

- Maiti, S. K. and Mandal J. N., 1985. Rammed Earth House Construction. *Journal Geotechnical Engineering*, 111 (11), 1323-1328.
- Mathur, G. C. Improving Earth Houses, 161-165.
- McHenry, P. G., 1984, *Adobe and Rammed Earth Buildings. Design and Construction*. A Wiley-Interscience Publication, New York, USA.
- Middleton, G. F., 1952, Earth-Wall Construction. Pisé or Rammed Earth; Adobe or Puddled Earth; Stabilised Earth. Bulletin No. 5, First edition, Department of Works and Housing, Sydney, Australia.
- Middleton, G. F., 1953, *Built your House of Earth. A manual of Pisé and Adobe Construction*. Angus and Robertson, Sydney, Australia.
- Middleton, G.F., 1992 (revised by Schneider L. M., 1987), *Bulletin 5. Earth Wall Construction*. Fourth Edition, CSIRO Division of Building, Construction and Engineering, North Ryde, Australia.
- Minke, G., 2000, *Earth Construction Handbook. The building Material Earth in Morden Architecture*. WIT Press, Southampton, UK.
- Montgomery, D. *How does cement stabilisation work?* Coventry: Development Technology Unit, School of Engineering, University of Warwick, October 1998. Stabilised Soil Research Progress Report SSRPR02.
- Montgomery, D. *Physical characteristics of soils that encourage SSB breakdown during moisture attack*. Coventry: Development Technology Unit, School of Engineering, University of Warwick, November 1998. Stabilised Soil Research Progress Report SSRPR03.
- MOPT (Ministerio de Obras Publicas y Transportes), 1992. *Bases Para el Diseno y Construction con Tapial*, Madrid.
- Morris, H. W. The Strength of Engineered Earth Buildings. *IPENZ Annual Conference, Sustainable Development*, Hamilton, 5-9th February 1993, 660-671.
- New Mexico Adobe and Rammed Earth Building-Code*, 1991. Published by Regulation & Licensing Department, Construction Industries Division, General Construction Bureau, Santa Fe, New Mexico.
- Norton, J., 1997, *Building with Earth. A handbook*. Second Edition, Intermediate Technology Publications, London, UK.
- NZS 4297:1998, New Zealand Standard. *Engineering Design of Earth Buildings*. Standard New Zealand, Wellington, New Zealand.
- NZS 4298:1998, New Zealand Standard. *Materials and Workmanship for Earth Buildings*. Standard New Zealand, Wellington, New Zealand.
- NZS 4299:1998, New Zealand Standard. *Earth Buildings Not Requiring Specific Design*. Standard New Zealand, Wellington, New Zealand.

References

- Oliver, D. and Whybird, D. Commercial Engineered Aggregate Construction – The Challenges of Innovation. *Innovation and Economics in Building Conference held in Brisbane Australia between the 23-24 September 1991*.
- Overseas Information Paper OIP 2, 1990, Building research Establishment, *Choosing soil for blockmaking*, Building research Establishment, Watford, UK.
- Pearson, G, 1992. *Conservation of clay and chalk buildings*. Donhead.
- Popposwamy, *Rural India: Village houses in rammed earth*. Sri Aurobindo Ashram Press, Pondicherry, India.
- Radanovic, J., 1996, Design Criteria for Reinforced Stabilised Earth Structures, Thesis submitted for the degree of BSc, University of Western Australia, Crawley, Australia.
- Rauch, M, 2002. *Rammed Earth – Anwendungsbeispiele, Probleme und Potentiale*. Proceedings Moderner Lehmabau, Berlin.
- Roach, S. 1994. *An analysis of the compressive strength of rammed earth walls*. BEng project report, Department of Resource Engineering, University of New England, Australia.
- Saxton, R. H. The performance of cob as a building material. *The Structural Engineer*. 1995, Volume 73 No. 7, 111-115.
- SAZS 724:2001, Zimbabwe Standard. Rammed Earth Structures. Standards Association of Zimbabwe, Harare, Zimbabwe.
- Shihata, S. A. and Baghdadi, Z. A. Simplified Method to Assess Freeze-thaw Durability of Soil Cement. *Journal of Materials in Civil Engineering*. July/August 2001, vol. 13, No. 4, 243-243.
- Standards Australia, 2002, *The Australian earth building handbook*. Standards Australia, Sydney, Australia.
- The Cob Buildings of Devon 1, 1992, Devon Historic Building Trust, *History, Building Methods and Conservation*. DHBTr, Devon, UK.
- Tibbets, J., M. Emphasis on Rammed Earth – the rational. *Interamericas Adobe Builder*, 2001, 9, 4-33.
- United Nations (prepared by Fitzmaurise, R.), 1958, *Manual on Stabilised Soil Construction For Housing*, United Nations Publications, New York, USA.
- United Nations, 1964, *Soil-cement, its use in building*, United Nations Publications, New York, USA.
- Vale, B, 1973. *A Review of the Ministry of Agriculture's Earth Houses*. Autonomous Housing Study. Cambridge: Technical Research Division, Department of Architecture, University of Cambridge, Working Paper 17.
- Varma, P. L. and Mehra, S. R., Use of Soil-cement in House construction in the Punjab, *Indian Concrete Journal*, April 15th 1950, 91-96.

References

Venkatarama B. V. and Lokras S. S. Steam-cured stabilised soil blocks for masonry construction. *Energy and Buildings*. 1998, 29, 29-33.

Walker, P. Review and experimental comparison of erosion test for earth blocks, *Terra 2000, 8th International Conference on the study and conservation of earthen architecture organised by English Heritage and held in Torquay, May 2000*. English Heritage, 2000. pp. 177-181.

Wilhide, E, 2002, *Eco*. Quadrille publishing, London.

Williams-Ellis, C., 1916, *Building in cob, Pise and stabilized earth*. Donhead.

Williams-Ellis, C., Eastwick-Field, J. and E., 1999, *Building in Cob, Pise and Stabilised Earth*. Donhead Publishing, Dorset, UK.

Yttrup, P. J. 1985. Strength of earth masonry (Adobe) walls subjected to lateral wind forces. *Proceedings of the 7th International Brick Masonry Conference organised in Melbourne*, 981-991.

Bibliography

ACI Materials Journal Committee Report, 1990. State-of-the-art Report on Soil Cement, *ACI Materials Journal*. July-August, 395-417.

Adam, E. A. and Jones P. J. 1995. Thermophysical Properties of Stabilised Soil Building Blocks. *Building and Environment*. Vol. 30 No. 2, 245-253.

Ajaz, A. and Parry, R. H. G. 1976. Bending Test for Compacted Clays. Proceedings of the American Society of Civil Engineers, *Journal of the Geotechnical Engineering Division*. Vol. 102 No. GT9, 929-943.

Akinmusuru, J. O. 1994. Thermal Conductivity of Earth Blocks. *Journal of Materials in Civil Engineering*. Vol. 6 No. 3, 341-351.

A rammed earth house in Massachusetts. *APT Bulletin*. 1983, Vol. 15 No. 2, 33-37.

Algifri, A. H., Bin Gadhi, S. M. and Nijaguna, B. T. 1992. Thermal Behaviour of Adobe and concrete houses in Yemen. *Renewable Energy*. Vol. 2 No. 6, 597-602.

Alley, P. J. 1948. Rammed Earth Construction, *New Zealand Engineering*, June 10, 582.

Archer, J. & Archer G. 1981. Grass Roots Earth Builder's Companion. Night Owl Publishers, Shepperton, Vic., Australia.

Architects Journal. 2000. Rammed earth first for alternative technology HQ; Architects: pat Borer and David Lea., 212, 8, September 7th, 16.

Armstrong, S. 1988. Pied à terre, *New Scientist*, 10 March 1988, pp. 60-64.

ASTM D 560-89, 1989, The American Society for Testing and Materials, *Standard Test Methods for Freezing and Thawing Compacted Soil-Cement Mixtures*. ASTM Standards, Philadelphia, USA.

Bahadori, M. and Haghigat, F. 1985. Weekly Storage of Coolness in Heavy Brick and Adobe Walls. *Energy and Buildings*. 8, 259-270.

Betts, M.C. & Miller, T.A.N. 1921. Rammed earth walls for buildings. US Dept. of Agriculture. Farmers Bulletin No. 1500. Washington DC (US Govt. Printing Office).

Bergland, M. 1982. Rammed earth. An ancient building method made easier by new technology. *Fine Homebuilding*, 11, Oct.Nov., 20-25.

Bergland, M. 1986. Rammed-earth portfolio. *Fine Homebuilding*, 34, Aug./Sept., 35-39.

Bofinger, H. E. 1970. *The measurements of the tensile properties of soil-cement*. Berkshire: Road Research Laboratory, Ministry of Transport. RRL Report LR 365.

Borer, P. and Lea, D. 2000. Rammed earth first for alternative technology HQ. *Architects Journal*. Vol. 212 No. 8, 16.

BRE 75 years of building research, 1996, Building research Establishment, *Earth Building: A Topic of Continuing Interest*, Building research Establishment, Watford, UK.

Bibliography

Bryan, A. J. 1988. Soil/Cement as a Walling Material – II. Stress/Strain Properties. *Building and Environment*. Vol. 23 No. 4, 321-330.

Bryan, A. J. 1988. Soil/Cement as a Walling Material – II. Some Measures of Durability. *Building and Environment*. Vol. 23 No. 4, 331-336.

Building Design. 1999. Raw-earth centre on site; Architects: Pat Borer. 6, 1418, Nov. 12th.

Building Research Station. 1947. *Building in adobe, cob and pisé de terre*. Garston.

Building Research Station. 1950. *Soil stabilisation*. Garston.

Building Research Station. 1950. *Stabilised earth wall construction*. Garston.

Building Research Station. 1952. A laboratory examination of some properties of compacted soil-cement mixtures. BRS Note No. D.174, Garston.

Building Research Station, 1952. *Stabilised earth walls – construction*. Colonial Building Notes, No. 8, August.

Building Research Station, 1953. *Stabilised earth walls – surface finishes*. Colonial Building Notes, No. 14, July.

Building Technology File Number Thirteen, 1996, CSIRO Division of Building, Construction and Engineering, *Pisé (Rammed Earth) Construction*. CSIRO Australia, North Ryde, Australia.

Building Technology File Number Twelve, 1996, CSIRO Division of Building, Construction and Engineering, *Earth Wall Construction*. CSIRO Australia, North Ryde, Australia.

Centre for the Development of Enterprise, 2000, *Compressed earth block testing procedures*.

Clarke, R. 2001. How Energy Efficient are Rammed Earth Walls? *Chartered Building Professional*. February 2001,14.

Coad, J. R. 1979. Lime-stabilised soil building blocks. *Building Research and Practice*. March-April, 80-89.

Corey, L. E. 1977. Earth Materials in Energy Conservative Construction. *Proc Annual Eng Geology Soils Eng Sym*. R20539, 231-241.

Commonwealth Experimental Building Station. 1951. *Earth wall construction II. Pisé (rammed earth)*. Department of Works and Housing, Notes on the Science of Building No. SB 20, Chatswood, Sydney.

Commonwealth Experimental Building Station. 1952. *Earth wall construction IV. Stabilized earth*. Department of Works and Housing, Notes on the Science of Building No. SB 22, Chatswood, Sydney.

Bibliography

Commonwealth Experimental Building Station. 1953. *Rammed earth walls plated with stabilized earth*. Department of Works and Housing, Technical Record, Chatswood, Sydney.

Contal, M.H. 1987. Habitat sorti de terre. *Architecture Interieure Cree*, 218, June/July, 108-111.

Construction Review. 1984. Stabilised Rammed Earth. 57 Part 1, 38-43.

Cointeraux, F. 1806. *Du nouveau pisé ou L'art de faire le pisé par appareil*. Paris.

CRATerre, 1982. Recommendations pour la conception des bâtiments du Village Terre. Plan Construction/AGRA.

CRATerre, 1990, *Raw Earth Architecture, Renaissance of Architecture in France*, CRATerre, Villefontaine, France.

Crowley, M. 1997. Quality Control for Earth Structures. *Australian Institute of Building Papers*. 8, 109-118.

Cytryn, S. 1957. *Soil construction: its principles and application for housing*. Ministry of Labour, State of Israel, Housing Division, Weizmann Science Press, Jerusalem.

Dayton, L. 1991. Saving mud monuments, *New Scientist*, 25 May 1991, pp. 38-42.

Deeks, A., 1998, Design Criteria for Reinforced Stabilised Earth Structures, Thesis submitted for the degree of BSc, University of Western Australia, Crawley, Australia.

Delarue, J. 1954. Cement stabilized pisé de terre in Morocco. *RILEM Bulletin* (18), 24-6.

De Long, H.H., 1959. Rammed earth walls. Circular 149, South Dakota State College, Brookings, USA.

Dethier, J. 1982. *Down to Earth*. Thames & Hudson, London.

Dethier, J. 1985. Story of pisé. *Architectural Review*, 178, 1064, Oct., 67-68.

Drewes, F.F. 1996. Ursprunge: Wohnhaus in Tuscon, Arizona. *Deutsche Bauzeitschrift*, 44, 10, October, 90-95.

Earth Building Association of Australia, 2001, *Earth Building Book. Draft for Comment*. Draft Code 05/01. Earth Building Association of Australia, Wangaratta, Australia.

Easton, D., 1996, *The Rammed Earth House*. Chelsea Green Publications Company, Vermont, USA.

Eben Saleh, M. A. 1990. Adobe as a thermal regulating material. *Solar & Wind Technology*. Vol. 7 No. 4, 407-416.

Egeland, P., 1988, *Cob and Thatch*, Devon Books, Exeter.

Bibliography

Elizabeth L. & Adams C., 2000, *Alternative Construction. Contemporary Natural Building Methods*. John Wiley & Sons, New York, USA.

Etzion, Y. and Saller, M. 1987. Earth construction – a review of needs and methods. *Architectural Science Review*, 30, 2, June, 43-48.

Evans, I, Smith, M.G. & Smiley, L. 2002. *The Hand Sculpted Book*. Chelsea Green Publications.

Factsheet, 2000, Centre for Alternative Technology, *AtEIC. Autonomous Environmental Information Centre*. Centre for Alternative Technology Publications, Machynlleth, UK.

Fitzmaurice, R. 1958. *Manual on Stabilised Soil Construction For Housing*, United Nations Publications, New York, USA.

Fromonot, F. 1997. Ateliers a Tuscon [Artists' studios and residences in Tuscon]; Architects: Rick Joy. *Architecture D'Aujourd'Hui*, 312, September, 48-51.

Gommersall, F. 2002. Earth Construction. *Building for a Future*. No. 3, Volume 12.

Gooding, D. 1993. E. M. *Soil Testing for Soil-Cement Block Preparation*. Coventry: Development Technology Unit, School of Engineering, University of Warwick, Working Paper No. 38.

Govaer, D. 1987. Apparent Thermal Conductivity of a local Adobe Building Material. *Solar Energy*. Vol. 38 No. 3, 165-168.

Graham, T. 2000. Coming of age; Architects: Pat Borer and David Lea. *Touchstone*, 8, Autumn, 20-25.

Guillaud, H, Joffroy, T. and Odul, P., 1995, *Compressed earth blocks: vol. 2 manual of design and construction*. Vieweg, Germany.

Hall, M., 2002. *Rammed earth: traditional methods, modern techniques, sustainable future*, Building Engineer, Nov., 22-24.

Hammond, A. A. 1973. Prolonging the life of earth building in the tropics, *Building Research and Practice*. pp. 154-163.

Hannay, P. 2000. Ground force; Architects: Pat Borer and David Lea. *RIBA Journal*, 107, 11, 34-40.

Heathcote, K. A. 1995. Durability of earthwall buildings. *Construction & Building Materials*. Vol. 9 No. 3, 185- 189.

Heathcote, K.A. and Ravindrarajah R.S. 2000. Relationship between spray erosion tests and the performance of test specimens in the field. *Proc. International Conference on Sustainable construction into the next millennium: environmentally friendly and innovative cement based materials*, João Pessoa, Brazil, November, 327-336.

Bibliography

Heathcote, K., A. 1995. Resistance of Earthwall Buildings to Weathering by Wind-driven Rain. *Australian Institute of Building Papers*. 6, 13-20.

Heathcote, K.A., 2001, *An investigation into the erosion of earth walls*, PhD Thesis, University of Technology, Sydney.

Hladik, M. 2002. Rammed earth: Martin Rauch. *Architecture Aujourdhui*. 339, 10-11.

Hodder, G. Structural Design of Earth Building, pp. 473-484.

Houben, H. and Guillaud H., 1994, *Earth Construction, A comprehensive Guide*. Intermediate Technology Publications, London, UK.

Hughes, R. 1983. Material and Structural Behaviour of soil constructed walls. *Momentum*. pp. 175-188.

Hurd, J. and Gourley, B., 2000, *Terra Britannica. A celebration of earthen structures in Great Britain and Ireland*. James & James (Science Publishers) Ltd, London, UK.

Jaggard, W. R. 1921, *Experimental Cottages*. Dept. Scientific and Industrial Research, HMSO, London.

Jaggard, W. 1922. *Building in Cob and Pisè de Terre*, HMSO: Department of Scientific and Industrial Research, pp 1-40. Special Report No. 5.

Jakeman. 1921. Tests on pisè de terre walls. National Physical Laboratory. Report for the year 1920, p. 104, London (HMSO).

Johnson, S.W. 1806. *Rural economy: containing a treatise on pise building as recommended by the Board of Agriculture in Great Britain with improvements by the author*. Published I.Riley, New York.

Kapfinger, O., 2001, *Martin Rauch: Rammed Earth | Lehm und Architektur | Terra cruda*. Birkhäuser, Basel, Switzerland.

Keable, J. 1994. *Rammed Earth Standards*. ODA Final Project Report R 4864C.

Keable, J., 1996, *Rammed Earth Structures. A code of Practice*. Intermediate Technology Publications, London, UK.

Keable, R. 2001. East of Eden. *Building for a Future*. No. 4, Volume 10.

Keefe, N. K., 1998, *An investigation into the causes of structural failure in traditional cob buildings*, M.Phil. Thesis, University of Plymouth (Unpublished).

Keefe, L., Watson, L. and Griffiths, R. 2001. A proposed diagnostic survey procedure for cob walls. *Proceeding of the Institution of Civil Engineers Structures and Buildings*. February, 1, 57-65.

Bibliography

Kenmogne, 1993, D egradation des mat eriaux de construction: contribution   l' tude de la faisabilit  des terres argileuses en construction, PhD Thesis, De L'Universite Joesphn Fourier, Grenoble.

Kennedy, J.F., Bates, A., Wanek, C. and Smith, M. 2002. *The Art of Natural Building*. New Society Publications.

Kerali, A.G., 2001, *Durability of compressed and cement-stabilised building blocks*, PhD Thesis, University of Warwick.

King, B. P. E., 1996, *Buildings of Earth and Straw. Structural Design for Rammed Earth and Straw Bale Architecture*. Ecological Design Press, Sausalito, California, USA.

Kornouchow, M. 1933. Investigations on the strength and stability of eccentrically loaded pis  de terre walls. Symposium in memory of Kost Kostyovitch Siminsky Academy of Science of the Ukrainian S.S.R. Institute of Applied Mechanics, Kiev. (in Ukrainian)

Lawson B., 1996, *Building Materials Energy and the Environment. Towards Ecologically Sustainable Development*. The Royal Australian Institute of Architects, Red Hill, Australia.

Lehmbau Regeln. Begriffe; Baustoffe; Bauteile., 1999, Friedr. Vieweg & Sohn Verlagsgesellschaft mbH, Braunschweig/Wiesbaden, Germany.

Lilley, D. M., Robinson, J. 1995. Ultimate strength of rammed earth walls with openings. *Proceeding of the Institution of Civil Engineers Structures and Buildings*. August, 110, 278-287.

Little, B. and Morton, T., 2001, *Building with Earth in Scotland. Innovative Design and Sustainability*. Scottish Executive Central Research Unit, Edinburgh, UK.

Litton, L. L. and Lohnes, R. A. Attrition Rates of Soil-Cement Subject to Water Jets. *TRB Transportation Research Record.*, 941, 18-23.

Maiti, S. K. and Mandal J. N. 1985. Rammed Earth House Construction. *Journal Geotechnical Engineering*. 111 (11), 1323-1328.

Maldonado Ramos, L (and others). 1997. La technical del tapial en la cominidad autonoma de Madrid. Aplicacion de Nuevos materials para la consolidacion de muros de tapia [The technique of 'tapia', rammed earth, in the Madrid district. Application of the new materials in the consolidation of rammed earth walls]. *Informes de la construccion*. Vol. 49 no. 452, 27-37.

Mathur, G. C. Improving Earth Houses, 161-165.

McCann, J, 1995, *Clay and cob buildings*, Shire Publications.

McHenry, P. G., 1984, *Adobe and Rammed Earth Buildings. Design and Construction*. A Wiley-Interscience Publication, New York, USA.

Meade, M. & Garcias, J.C., 1985. Return to earth. *Architectural Review*, No. 63/10.

Bibliography

- Merrill, A.F. 1979. *The rammed earth house*. Ann Arbor, London.
- Middleton, G. F., 1952, Earth-Wall Construction. Pisé or Rammed Earth; Adobe or Puddled Earth; Stabilised Earth. Bulletin No. 5, Department of Works and Housing, Sydney, Australia.
- Middleton, G. F., 1953, *Built your House of Earth. A manual of Pisé and Adobe Construction*. Angus and Robertson, Sydney, Australia.
- Middleton, G.F., 1987 (revised by Schneider L. M., 1992), *Bulletin 5. Earth Wall Construction*. Fourth Edition, CSIRO Division of Building, Construction and Engineering, North Ryde, Australia.
- Miller L. and Miller D., 1980. *Manual for building a rammed earth wall*. Rammed Earth Homes, c/o Miller L. and D., Greeley, USA.
- Miller L., Miller D., 1982, *Rammed Earth. A selected Bibliography with a World Overview*. Rammed Earth Institute International, Colorado, USA.
- Ministerio de Obras Públicas y Transportes, 1992, *Bases Para el Diseña y Construcción Con Tapial*, Centro de Publicaciones, Secretaria General Técnica, Ministerio de Obras Públicas y Transportes, Madrid, Spain.
- Minke, G., 2000. *Earth Construction Handbook. The building Material Earth in Modern Architecture*. WIT Press, Southampton, UK.
- Moderner Lehmnbau 2002, Internationale Beiträge zum modernen Lehmnbau*, KirchBauhof gGmbH und bei den Autoren, April 2002, Berlin Germany.
- Montgomery, D. 1998. *How does cement stabilisation work?* Coventry: Development Technology Unit, School of Engineering, University of Warwick, October. Stabilised Soil Research Progress Report SSRPR02.
- Montgomery, D. 1998. *Physical characteristics of soils that encourage SSB breakdown during moisture attack*. Coventry: Development Technology Unit, School of Engineering, University of Warwick, November. Stabilised Soil Research Progress Report SSRPR03.
- Montgomery, D. and Thomas, T. 2000. *Dynamic Compaction of Soil for Low-cost Building Blocks*. Coventry: Development Technology Unit, School of Engineering, University of Warwick, January. Working Paper No. 53.
- Morgan, C. & Scott, C. 2002. Light Earth. *Building for a Future*. No. 3, Volume 12.
- Morris, H. W. 1993. The Strength of Engineered Earth Buildings. *IPENZ Annual Conference, Sustainable Development*, Hamilton, 5-9th February, 660-671.
- Mukerji, K., 1989. *Rammed earth construction*. United Nations ESCAP, Building Technology Series, No. 1.
- Notes from the Information Bureau of the Building Research Station. 1935. *Durability of pisé de terre dwellings*. 3rd series, No. 3 (157).

Bibliography

Norton, J., 1997, *Building with Earth. A handbook*. Second Edition, Intermediate Technology Publications, London, UK.

NZS 4297:1998, New Zealand Standard. *Engineering Design of Earth Buildings*. Standard New Zealand, Wellington, New Zealand.

NZS 4298:1998, New Zealand Standard. *Materials and Workmanship for Earth Buildings*. Standard New Zealand, Wellington, New Zealand.

NZS 4299:1998, New Zealand Standard. *Earth Buildings Not Requiring Specific Design*. Standard New Zealand, Wellington, New Zealand.

Ogunye, F. O. and Boussabaine, H. 2002. Diagnosis of assessment methods for weatherability of stabilised compressed soil blocks. *Construction and Buildings Materials*. 16, 163-172.

Ola, S. A. and Mbata, A. 1990. Durability of Soil-cement for building purposes – Rain erosion resistance test. *Construction & Building Materials*. Vol. 4 No. 4, 182- 187.

Oliver, D. and Whybird, D. 1991. Commercial Engineered Aggregate Construction – The Challenges of Innovation. *Innovation and Economics in Building Conference held in Brisbane Australia between the 23-24 September 1991*.

Olivier, M. and El Gharbi, Z. Sisal Fibre Reinforced Soil Block Masonry. pp 55-58.

Olivier, M. and Mesbah, A. 1995. Constitutive equations for compacted soils. *Unsaturated Soils*. 2, 765-773.

Olivier, M and Mesbah, A. 1987. Influence of Different Parameters on the Resistance of Earth used as a Building Material. *Proceeding of the Mud Architecture International Conference organised in Bangalore*.

Oswell, J. M. and Joshi, R. C. 1986. Development of an Erosion Test for Soil Cement. *Geotechnical Testing Journal*. Volume 9 No. 1, 19-23.

Out of Earth Conference, 1994, ed. Watson and Harding, Plymouth.

Out of Earth II Conference, 1995, ed. Watson & Harries, Plymouth.

Overseas Information Paper OIP 2, 1990, Building research Establishment, *Choosing soil for blockmaking*, Building research Establishment, Watford, UK.

Patty, R. L. 1936. Age-strength Relationship For Rammed Earth. *Engineering News-Record*, July, 177, 44.

Patty, R.L. & Minium L.W. *Rammed earth walls for farm buildings*. Agricultural Experiment Station, South Dakota State College.

Pearson, G. T., 1992, *Conservation of Clay and Chalk Buildings*. Donhead, London, UK.

Bibliography

Portland Cement Association. 1946. *Application of soil-cement to low-cost house and farm building construction*. Soil-cement information. Soil-cement Bureau No. SCB. 13, Chicago.

Popposwamy, 1979, *Village Houses in Rammed Earth*, Rural India. ISBN 81-7058-412-4.

Radanovic, J., 1996, Design Criteria for Reinforced Stabilised Earth Structures, Thesis submitted for the degree of BSc, University of Western Australia, Crawley, Australia.

Rammed earth. An ancient building method made easier by new technology. *Fine Homebuilding*. 1982, 11, 20-25.

Rammed-earth portfolio. *Fine Homebuilding*. 1986, 34, 35-39.

Ransom, W.H. 1963. *Soil stabilization: a review of principles and practice*. Building Research Station Note E1299/Tropical Building Studies No. 5, Garston.

Ransom, W.H. 1963. *Building with cement-stabilized soil: tests for suitability*. Building Research Station Note E1333, Garston.

Reichsarbeitsminister. 1942/3. Regulations respecting earth structures. Bauverwaltung, 62 (31/32), 383-4, No. 207.

RIBA, 1951. *Rammed earth, cob and pisé de terre bibliography*. London.

Rigassi, V., 1995, *Compressed earth blocks: vol. 1 manual of production*. Vieweg, Germany.

Roach, S.R., 1994, An analysis of the compressive strength of rammed earth walls, BEng Final Year Thesis, University of New England, Australia.

Rogers C. D. F., Glendinning S., Roff, T. E. J. 1997. Lime modification of clay soils for construction expediency. *Proceeding of the Institution of Civil Engineers, Geotechnical Engineering*. 125, 242-249.

Sadrekarimi, J. and Ebrahimnezhad, E. 2000. Compressive Strength-Freeze and Thaw Durability Correlation in Soil-cement Design. *Photo Journal, Institution of Engineers India – Civil Engineering Division*. 81, 29-32.

Saxton, B. and Coventry, K. 1995. The Engineering Performance of Cob. In: Watson L. and Harries R. (ed) *Out of Earth II, National Conference on Earth Buildings organised by the Centre for Earthen Architecture of the University of Plymouth*. Plymouth: University of Plymouth, pp.65-77.

Saxton, R. H. 1995. The performance of cob as a building material. *The Structural Engineer*. Volume 73 No. 7, 111-115.

Schrader, C. A. 1981. Rammed Earth Construction: A re-emerging Technology, *6th Natural Passive Solar Conference held in 1981*.

Seed, H. B. and Chan, C. K. 1959. Structure and Strength Characteristics of Compacted Clays. *Journal of Soil Mechanics Foundation Division*. 85 No. SM5.

Bibliography

- SHELTER*, 1973, Shelter Publications, California.
- Simmonds, A & Keable R. 1992. Down to Earth. *Building for a Future*, No. 2 Volume 2.
- Sinha, S. and Schmann, P. 1994. Earth Building Today. *The Architects Journal*. 22 September.
- Stulz, R. and Mukerji, K., 1988, *Appropriate building materials*, SKAT publications, Switzerland.
- Smith E. W., Austin G. S., 1996, *Adobe, pressed-earth, and rammed-earth industries in New Mexico (revised edition)*. *Bulletin 159*. New Mexico Bureau of Mines & Mineral Resources, Socorro, USA.
- South Dakota State College. 1940. *Paints and plasters for rammed earth walls*. Agricultural Experimental Station Bulletin 336, Brookings, South Dakota.
- Spence, R. J. S. 1975. Predicting the Performance of Soil-cement as a building Material in Tropical Countries. *Building Science*. Vol. 10, 155-159.
- Spence, R.J.S and Cook, D.J., 1982, *Building materials in developing countries*, Wiley.
- Standards Association of Zimbabwe, 2001. *Rammed Earth Structures*, SAZS 2001 724.
- Standards Australia, 2002. *The Australian Earth Building Handbook*. Sydney. 151 pp.
- Steingass P. and Vietzen W., 1999, *Moderner Lehm-bau Einführung und Messekatalog 1999*, Overall Verlag Berlin, Berlin, Germany.
- Steingass P., 2000, *LEHM 2000*, Overall Verlag Berlin, Berlin, Germany.
- Terra 2000, 8th International Conference on the study and conservation of earthen architecture. Postprints*. English Heritage, May 2000, Torquay, Devon.
- Terra 2000, 8th International Conference on the study and conservation of earthen architecture. Preprints*. English Heritage, May 2000, Torquay, Devon.
- The Cob Buildings of Devon 1, 1992, Devon Historic Building Trust, *History, Building Methods and Conservation*. DHBT, Devon, UK.
- The Cob Buildings of Devon 2, 1993, Devon Historic Building Trust, *Repair and Maintenance*. DHBT, Devon, UK.
- Thompson, F. 1996. Earthly Fortresses + Unknown Communal Rammed-Earth Fortresses In Southern China. *Architecture Review*. 199 (1188), 84-86.
- Tibbets, J., M. 2001. Emphasis on Rammed Earth – the rational. *Interaméricas Adobe Builder*, 9, 4-33.
- United Nations, 1964, *Soil-cement, its use in building*, United Nations Publications, New York, USA.

Bibliography

Vale, B., 1973, *A review of the Ministry of Agriculture's earth houses*, Working Paper 17, Dept. of Architecture, University of Cambridge.

Varma, P. L. and Mehra, S. R. 1950. Use of Soil-cement in House construction in the Punjab, *Indian Concrete Journal*, April 15th, 91-96.

Venkatarama B. V. and Jagadish K. S. 1991. Field Evaluation of Pressed soil-cement blocks. *Proceedings of 4th International Seminal on Structural Masonry for Developing Countries organised by I.I.T. in Madras*, December, pp. 168-175.

Venkatarama B. V. and Jagadish K. S. 1987. Spray Erosion Studies on Pressed Soil Blocks. *Building and Environment*, Vol. 22 No. 2, 135-140.

Venkatarama, B. V. and Jagadish, K. S. 1993. The static compaction of soils. *Géotechnique*, 43 No. 2, 337-341.

Venkatarama B. V. and Lokras S. S. 1998. Steam-cured stabilised soil blocks for masonry construction. *Energy and Buildings*. 29, 29-33.

Voelcker, A. 2002. Rammed earth: Martin Rauch. *Architecture Review*. 211(1263), 97.

Walker, P. and Dobson, S. 2001. Pullout Tests On Deformed and Plain Rebars in Cement-stabilised Rammed Earth. *Journal of Materials in Civil Engineering*. Vol. 13 No.4, 291-297.

Walker, P. Performance of Stabilised Soil Block Masonry under Uniform and Concentrated Compressive Loading. *Proc. British Masonry Society*, No. 7, HWH West (ed.), London,. 49-53.

Walker, P. 2000. Review and experimental comparison of erosion test for earth blocks, *Terra 2000*, 8th International Conference on the study and conservation of earthen architecture organised by English Heritage and held in Torquay, May. English Heritage, 2000. pp. 177-181.

Walker, P. and Stace, T. 1997. Properties of some cement stabilised compressed earth blocks and mortars. *Materials and Structures*. 30, 545-551.

Walker, P. 1995. Strength, Durability and Shrinkage Characteristics of Cement Stabilised Soil Blocks. *Cement & Concrete Composites*. 17, 301-310.

Walker, P. 1999. Bond characteristics of earth block masonry, *ASCE Journal of Materials in Civil Engineering*, 11, 3, pp 249-256.

Walker, P. 2000. Review and experimental comparison of erosion tests for earth blocks, in *Proceedings 8th International conference on the study and conservation of earthen architecture*, pp 176-181, Torquay, May.

Walker, P., Ayala, R. & Dobson, S. 2002. Reinforced Composite Rammed Earth in Flexure, with R.Ayala and S.Dobson, in *Proceedings 3rd International Conference on Non-Conventional Materials & Technologies*, Hanoi, 439-445.

Bibliography

- Warren, J., 1999, *Conservation of earth structures*, Butterworth-Heinemann, Oxford.
- Webb, T.L., Cilliers, T.F. & Stutterheim, N. 1950. The properties of compacted soil and soil-cement mixtures for use in building. South African Council for Scientific and Industrial Research, National Building Research Institute, Series DR2, Pretoria.
- Webb, D. 1995. Performance Consideration for the use of stabilised soil Building Blocks with Cob Construction in the United Kingdom. *Proceedings of the Out of Earth II Conference held in the University of Plymouth*. pp. 90-117.
- Webb, M. 2000. Earth works: Long Meadow Ranch winery, Napa Valley, Ca. *Interiors*, 159, 8, August, 54-59.
- Weiner, P. 1996. Rammed-earth compound. *Fine Homebuilding*. 101, 90-95.
- Weller, Ho. O. 1922. *Building in Cob and Pisè de Terre*. HMSO: Department of Scientific and Industrial Research, pp. 1-40. Special Report No.5.
- Wilds, W. 1835. *Elementary and practical instructions on the art of building cottages and houses for the humbler classes*. John Weale, London.
- Williams-Ellis, C., 1919, *Cottage Building in Cob, Pisè, Chalk and Clay*. Country Life, London, UK.
- Williams-Ellis, C., Eastwick-Field, J. and E., 1919, *Building in Cob, Pisè and Stabilised Earth*. Cambridge University Press, Cambridge, UK.
- Williams-Ellis, C., Eastwick-Field, J. and E., 1999, *Building in Cob, Pisè and Stabilised Earth*. Donhead Publishing, Dorset, UK.
- Wojciechowska, P., 2001, *Building with Earth*, Chelsea Green Publications, USA.
- Wolfskill, L.A. 1963. *Handbook for building homes of earth*. Agricultural and Mechanical College of Texas, Texas Transportation Institute, Bulletin 21, Texas.
- Yttrup, P. J. 1985. Strength of earth masonry (Adobe) walls subjected to lateral wind forces. *Proceedings of the 7th International Brick Masonry Conference organised in Melbourne*, 981-991.
- Zavoni E. H., Bernales J. J. B., Neumann J. V. and Mehta P. K. 1988. Improving the moisture resistance of adobe. *Materials and Structures/Matériaux et Constructions*. 21, 213-221.
- Zukunft Lehm bau. 2002. Conference, Symposium and Annual General Meeting. Dachverband Lehm e.V./Bauhaus-Universität Weimar.
- Zur Nieden, G. and Ziegert, C., 2002, *Neue Lebn-Hauser international: projektbeispiele, konstruktion, details*. Bauwerk Verlag.

Useful Internet Addresses

<http://www.aseg.net>

<http://www.bath.ac.uk/~abspw/index.html>

<http://www.cat.org.uk>

http://www.ceetydesorg/main_eng.htm

<http://www.craterre.archi.fr>

<http://www.dab.uts.edu.au/ebi>

<http://www.earthbuilding.com>

<http://www.earthbuilding.org.nz>

<http://www.earthconstruction.com/earth.htm>

<http://www.ebaa.asn.au>

<http://www.ecobuildnetwork.org>

<http://www.edenproject.com>

<http://www.engwarwick.ac.uk/DTU/pubs/tr/rwh/rwhtr03/tr03.html>

<http://www.hahaha.com.au/rammed.earth>

<http://www.maharishi-european-sidhaland.org.uk/ArtWoodleyPark.htm>

http://mysite.freerve.com/Jasmine_Cottage

<http://www.ramderth.com>

<http://www.rammed-earth.info>

<http://www.scotland.gov.uk/cry/kd01/orange/bwes-03.asp>

<http://www.sheepdrove.com>

<http://www.shu.ac.uk/schools/sed/earth>

<http://www.sustainable.com.au/index.html>

<http://www.tech.plym.ac.uk/soa/acrh/earth.htm>

http://www.toolbase.org/docs/MainNav/NewBuildingTechnologies/2142_rmd_earth.html