

Intuitive interactive form finding of optimised fabric-cast concrete

A Bak¹, P Shepherd¹, P Richens¹

¹ *Department of Architecture and Civil engineering
University of Bath
Bath BA2 7AY
United Kingdom
Andreas.Bak83@gmail.com P.Shepherd@bath.ac.uk; P.N.Richens@bath.ac.uk*

Producing organic shapes in concrete has been a challenging problem since complex freeform buildings became a major trend in contemporary architecture. Many different techniques for casting doubly-curved shapes have been proposed. Most of them produce elements which exactly match a preconceived design, but at a high cost in manufacture. Fabric formwork techniques (such as those pioneered at the Centre of Architectural Structures and Technology at the University of Manitoba (CAST)) are relatively economical, but require a form-finding approach which takes into account the physics of casting, as well as structural and functional requirements of the finished element.

The research presented here involves a specialised methodology for the design and manufacture of optimised concrete elements cast in fabric formwork. Using a novel software tool, our approach lies in between the largely intuitive methods reported by CAST and the precise but expensive computer-controlled manufacturing methods normally used in practice. Combining topological optimisation with computational form-finding, the developed software guides the designer towards a shape that is economical in both material and manufacturability. By combining knowledge of computational structural analysis, optimisation algorithms, fabric simulation and the practical casting techniques of fabric formwork; the gap between structurally optimised forms, and those developed intuitively by fabric casting, can be bridged. This is demonstrated through a case study involving the computational design of a centrally supported slab, supplemented with design studies realised using plaster scale models.

1 Introduction

The fluid state of concrete during the casting process has throughout history given rise to the design of a vast variety of doubly curved shapes only limited by the development of the formwork techniques. A huge range of methods for casting doubly curved shapes has been proposed and they all differ in level of accuracy, complexity and cost of manufacture.

1.1 Fabric formwork

At one end of the scale is the research in fabric formwork conducted by Mark West and his colleagues at the Centre for Architectural Structures and Technology (CAST) at the University of Manitoba in Canada. CAST is one of the main contributors to the

field and it houses one of the leading labs in the development and design of fabric formed structures. The centre focuses on exploring the natural shapes of a fabric under the influence by forces such as supports, self-weight of concrete and pre-stress and the use of this natural shape as a formwork for casting concrete elements. They specialise in a variety of pre-cast and in situ cast elements including beams, trusses, columns, wall panels, vaults and more recently slabs (West and Araya, 2009).

CAST has been involved in the design of a fabric formed canopy at the new Women's Hospital in Winnipeg. The canopy was designed by placing fabric on a flat base then rearranging it in to the desired shape taking into account the support conditions. The

driving force for the design using this method was aesthetics and the structural experience and intuition of the designer. A different casting technique has also been tested and used to create a capital star slab. In this case the fabric was placed over a predefined cut-out pattern, pre-tensioned and forced in to shape by a vacuum. The shapes created using the casting techniques developed by CAST can be aesthetically pleasing but are only structurally optimised to the extent of the designers intuition. For further information the reader is directed to the CAST website where other unpublished papers can be downloaded (CAST, 2011).

1.2 Topology optimisation of a continuum

On the other end of the scale many different techniques of casting doubly curved shapes have been proposed (Jepsen et al., 2010). Common to many is that they force the shape to mimic the desired design, but at a high price in the cost of manufacture.

Dombernowsky and Søndergaard (2010) show examples of topology optimised concrete slabs using off-the-shelf software. A full-scale prototype of a topology optimised slab was created using CNC milling of polystyrene blocks. This research was done as part of the research group "UNIKA beton" that explores the possibilities of constructing alternative concrete moulds using robot technology.

Topology optimisation covers the idea of redistributing material within a given design domain in such a way that the structure benefits from it the most. This optimal distribution is dependent on the support conditions and the governing loads on a structure.

Common to these well-known topology optimisation techniques is that they produce organic looking shapes that cannot usually be cast using conventional techniques. This paper proposes an optimisation algorithm that produces results that can be approximated by casting concrete using fabric formwork. This algorithm is based on the Bi-Directional Structural optimisation algorithm (BESO) (Huang and Xie, 2007) that relies on the engineering assumption that an optimal shape of a structure can be found by removing unutilised material from the design. The term 'bi-directional' refers to the fact that material can also be added back into the design if it is determined that the structure would benefit. The method is a combination of the Evolutionary Structural Optimisation method (ESO) (Xie, 1993) and the Additive

Evolutionary Structural Optimisation method (AESO) (Querin et al., 2000).

The optimisation algorithm proposed in this paper takes certain manufacturing constraints into account when determining where material should be removed or added. Instead of considering the full design domain, a sub domain consisting only of the external bottom face is used. Only material within this sub domain is considered when deciding what to remove or add. The introduction of this subdomain gives rise to an optimised shape without internal voids. The domain is updated at every iteration step of the optimisation. Using this method, a topology that can be approximated using fabric formwork is derived. This method can produce aesthetically pleasing concrete slabs whilst saving material with the fewest consequences in respect to manufacturability and structural integrity.

1.3 Fabric simulation

The optimised shape is used to determine the constraints of the fabric formwork by digitally draping a fabric over it.

Cloth simulation covers the challenges of simulating the non-linear and highly deformable mechanical and dynamic behaviour of cloth under the influence of forces and collisions inflicted by the surrounding environment. The main challenges of cloth simulation can be divided into main topics concerning mechanical properties, dynamic behaviour and collision handling, including self-intersection.

Numerical integration was used to find the time dependent coordinates of the cloth deforming under the influence of load. These coordinates are given implicit as a solution to Newton's second law of motion. This second order differential equation is often simplified to a set of two first order equations. The simplest integration method is the forward Euler integration where finite differences are used to calculate the positions and velocities for the next time step. An improvement of the Euler integration method is to reverse the order of the calculations of the position and the velocity (Nealen et al., 2006; Volino and Magnenat-Thalmann, 2001). For non-dissipative systems this reduces to the Störmer-Verlet integration scheme that was popularised by Verlet (1967), but used by Störmer as early as 1905. This method is much more stable than the simple Euler method and was used in this research.

To be able to define the internal forces of a viscoelastic non-linear behaviour fabric a material model is needed. Because of manufacturing methods cloth is often anisotropic, which further complicates the mechanical model. Volino, Magnenat-Thalmann et al. (2009) propose a simple approach to modelling the in-plane forces of a non-linear anisotropic material. The method is at the crossroad between the finite element and a mass-spring system. It considers forces between particles, but is calculated on the basis of accurate computation of the surface mechanical state in the element connected to each node.

A few different approaches to modelling the bending stiffness of the material is available (Grinspun et al., 2003; Volino and Magnenat-Thalmann, 2006). In this research a simple Laplacian-smoothing algorithm is used where each internal node of the surface is moved to a new position given by the average position of the average position of the neighbouring nodes projected to the surface normal.

The shape of the draped fabric is used to produce a cut-out pattern in a flat surface. This cut-out can be used as a guide when draping a “real life” fabric through it, thus creating an approximation to the optimised shape.

1.4 Aim of research

This paper presents a specialised method which puts the design of fabric cast structures somewhere between the intuitive approach conducted by CAST and an approach depending on the precise but expensive manufacturing methods available today. This approach provides an interactive framework for the design of fabric formwork. The method combines the use of topology optimisation techniques with computational form finding and helps guide the manufacturer towards an optimal design of a slab or beam based on the applied boundary conditions.

This paper proposes a way to bridge the gap between the ‘digital optimised’ and the ‘manufactured shape’ by combining knowledge of computational structural analysis, optimisation algorithms, fabric simulation and the practical casting techniques of fabric formwork.

2 Methods

2.1 Optimisation algorithm

As mentioned previously the optimisation algorithm is based on the BESO algorithm. This was chosen

because of the simplicity of the algorithm and the easy implementation into existing software code. The discrete nature of the BESO method allows easy evaluation of the optimised shape without the use of surface reconstruction techniques. The BESO method is more computationally efficient than for example the SIMP method (Bendsøe, 1989) because the entire domain does not have to be analysed at every iteration step. In BESO the number of equations decreases when elements are removed. Furthermore, starting the algorithm at an initial guess close to the desired volume fraction can speed up the process. This is especially useful when applying the algorithm to three-dimensional structures (Huang and Xie, 2007). A full description of the method is outside the scope of this paper, and the reader is referred to literature (Huang and Xie, 2007).

2.1.1 Method outline

Because of the manufacturing restrictions inherent in fabric-formed concrete, only the removal of elements from the external bottom face of the structure is allowed. Elements with no solid element directly connected in the negative direction of the z-axis are candidates for removal. This ensures that no internal voids are created in the structure allowing the shape to be cast with fabric formwork using the proposed casting technique. Similarly void elements are only eligible for addition if they have a solid element directly above them, which is in the positive direction of the z-axis. These elements are tested in every optimisation cycle and are from here on referred to as ‘candidates’. Figure 1 illustrates the candidates in a two-dimensional domain.

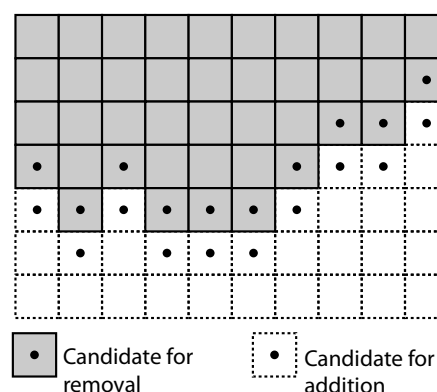

Figure 1: Candidates.

2.1.2 Validation of customised algorithm

This section contains an example that validates the correct implementation of the optimisation algorithm. As no examples using this strategy exist in literature, the validation is done by presenting performance graphs.

The structure is a slab supported by a central column with an evenly distributed load on the top (Figure 2). The material of the slab has a Young's modulus of 100000 MPa and a Poisson's ratio of 0.3. Because of symmetry only a quarter of the structure was modelled with mesh of 15x15x5.

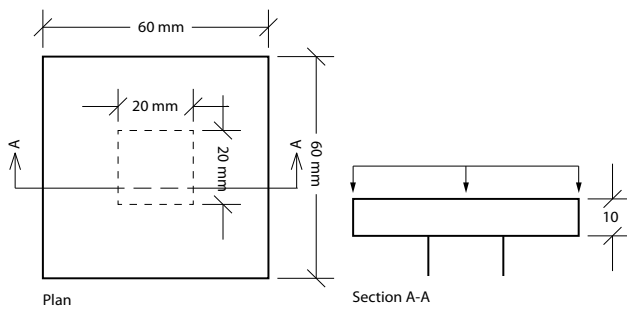

Figure 2: Dimensions

Figure 3 shows the optimised topology (turned upside down to aid visualisation).

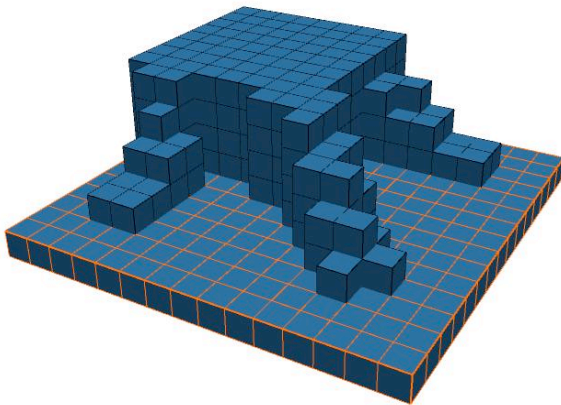

Figure 3: Optimised topology

The performance graphs in Figure 4 show the development in both volume fraction and compliance. The volume fraction denotes how much of the design domain is solid and the compliance acts as a measure of the stiffness of the structure. The smaller the compliance the higher overall stiffness. The idea of the optimisation process is decreasing the volume fraction with an increase in compliance as small as possible.

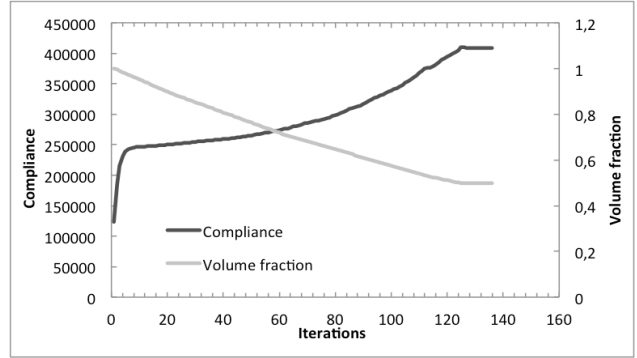

Figure 4: Performance graph

To further evaluate the performance, a design a factor called the performance index is introduced as

$$PI = \frac{1}{C \sum_{i=1}^N V_i} \quad (1)$$

where C is known as the mean compliance and V_i is the volume of the i th element.

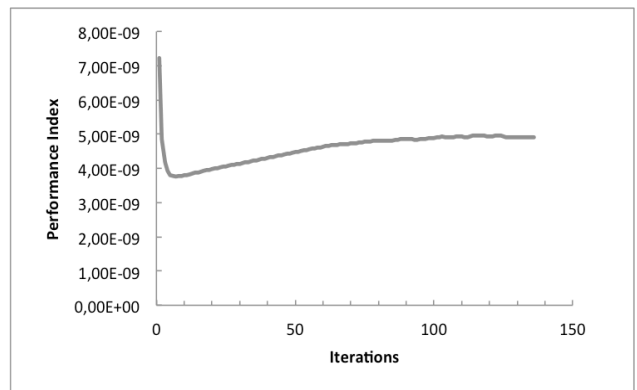

Figure 5: Performance graph

Figure 5 shows the development of the performance index. The drop of performance index in the first few iteration steps is due to the default element sensitivity values for the first iteration and should be ignored. The rest of the graph shows an increasing performance index, and therefore a gradually improving design towards the objective volume.

2.2 Collisions between the fabric and the optimised shape

The next step of the design process is to simulate a fabric draping over an optimised solid shape to determine how the shape could be cast using fabric form-work. To simulate this, collisions between the fabric and the solid have to be detected and dealt with in a proper manner.

The obvious approach of detecting collisions is to test every object against every other object with every iteration. The method is very easy to implement but not very computational efficient. The collision handling used in this research is based on the fact that the mesh is axis aligned and evenly spaced along the different axes. This leads to a very simple and computational effective way of handling collisions. The algorithm works by converting a coordinate in space to an address consisting of three integer values corresponding to the three axes. The values determine how many mesh-increments one should take along a given axis to find the element containing the coordinate. Using this approach collision detection can be reduced calculating the address and looking up the element with the corresponding address in a list and determine whether collision handling has to be triggered.

It is noted that this algorithm is computational independent of the number of elements in the static part of the collision, i.e. the optimised shape, which makes is very suitable for exactly this application.

Figure 6 show the implementation of the collision handling in the software by draping a fabric over an arbitrary solid shape.

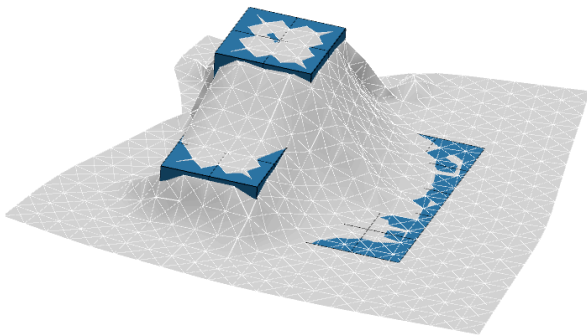

Figure 6: Simulation of fabric draped over an arbitrary shape

3 Results

The optimised structure presented below was created during the development of the software. This was done to test the concept and detect areas where the methods could be improved. The test led to some changes in the optimisation algorithm and the simulation of the in-plane forces of the fabric. In this experiment the optimisation algorithm was based on an earlier version BESO (Huang et al., 2006). The mechanical properties of the fabric were simulated using a simple mass-spring model.

This case study is a square slab supported by a single square column in the centre. The design-space of the slab is a volume with the dimensions 12x12x0.5m. The column is 2x2m in plan. The dimension is displayed in Figure 7.

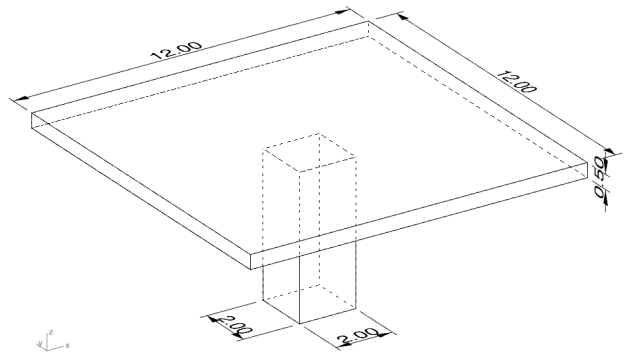

Figure 7: Slab dimensions

The slab is loaded with a uniformly distributed load on the top surface. The elements immediately beneath the loaded surface are defined as non-design space. These elements are frozen and cannot be removed by the optimisation algorithm, as this would create a design unsuitable for carrying the distributed load. The elements in the non-design space are part of the structural analysis and therefore contribute to the stiffness of the structure even though they cannot be removed..

The optimisation algorithm used here tends to cause asymmetric results even though a symmetric outcome is expected. This problem arises because the nature of the algorithm is to remove a certain number of elements. This can cause the algorithm to remove one element and keep another with the same sensitivity value, based on the sequence in which they are evaluated. When this happens the structure develops a tendency to emphasise the asymmetry in future iteration steps. The tendency can be minimised by slowing down the optimisation process, thus allowing the algorithm to 'self-correct'. However when large problems are analysed an increase in the number of iteration steps is undesirable. Symmetry planes can be used to eliminate this problem in some cases. In this case study three symmetry planes have been used. The first two are easily implemented when setting up the model. By introducing these planes the model can be reduced to a quarter size, which also lowers the computational time and memory usage.

However this model features a third symmetry plane along the diagonal of the slab. Because of the topology of the mesh this plane splits the element along the diagonal and the third symmetry plane cannot be modelled the same way as the first two.

In this case study a small function was introduced, which checks for symmetry at each iteration. When the optimisation algorithm toggles a voxel on or off it performs the same action on the element mirrored by the symmetry plane. This can be done using the voxel addresses introduced for the collision handling. This method forces the topology to be symmetric across the diagonal, but does not reduce the computation time or memory usage as all elements are still present in the model.

The dimension of the volume after being reduced by symmetry planes is 6x6x0.5m. This volume is discretised in to a 60x60x10 mesh.

3.1 Optimisation

The optimisation starts from a full domain of solid elements and gradually progresses toward a topology with only 30% solid elements. The performance index increases until iteration number 391 where the optimisation process becomes unstable. At this stage the removal of volume does not balance the increase in compliance and the performance index starts to drop.

The process of the entire optimisation is shown in Figure 8. The topologies shown are turned upside down to display the shapes of the underside of the slab.

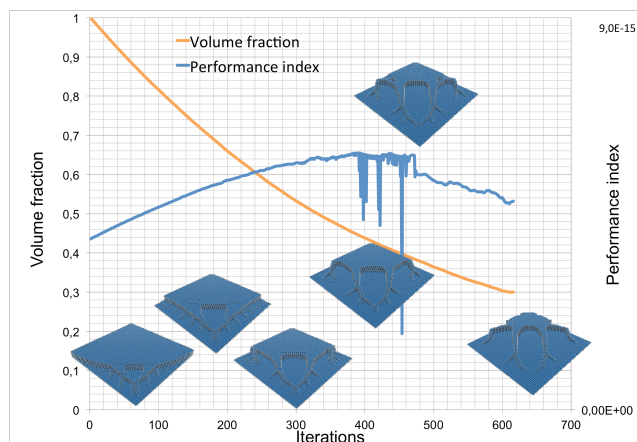

Figure 8: Optimisation process

The structure with highest performance index had a volume fraction of 45.5%. This structure was used for further development

3.2 Fabric draping

The next step was to drape fabric over the optimised shape and thereby determine the cut-out pattern for the form-work.

The symmetry planes discussed earlier can also be used in the draping process by only modelling a quarter of the fabric and constraining the fabric along the edges touching the planes. The diagonal symmetry plane was not used in the fabric simulation.

At this stage the mechanical properties couldn't be modelled accurately, and only relative stiffness values could be input. A more precise material model was implemented after these tests were conducted.

Nonetheless the software produced a shape of the draped fabric that could be used to find the cut-out pattern and thereby proving the concept. (Figure 9)

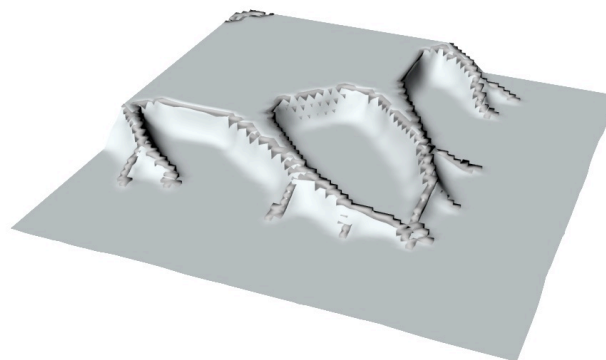

Figure 9: Fabric draped over optimized shape

The fabric was exported to a 3D modelling environment where the cut-out pattern was found using Boolean operations between the fabric and an intersection plane.

3.3 Scale models

The result from this initial run of the optimisation and formfinding process was used to create scale models using plaster. Fabric was placed on a flat base with a cut-out. The cut-out pattern defines the shape of the slab by allowing the fabric to sag under the weight of the plaster. A plate, supported from underneath, was placed beneath the cut-out to ensure that the sag of the fabric didn't exceed the boundaries of the design space. The scale of the plaster model is 1:12.

The same formwork was used to create two models, one with and one without pretension in the fabric, later referred to as model a and b respectively. The formwork is shown in Figure 10.



Figure 10: Formwork

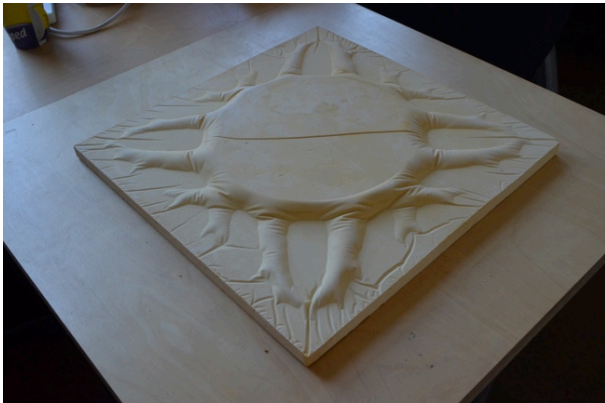

Figure 11: Model a



Figure 12: Model a, close-up



Figure 13: Model b

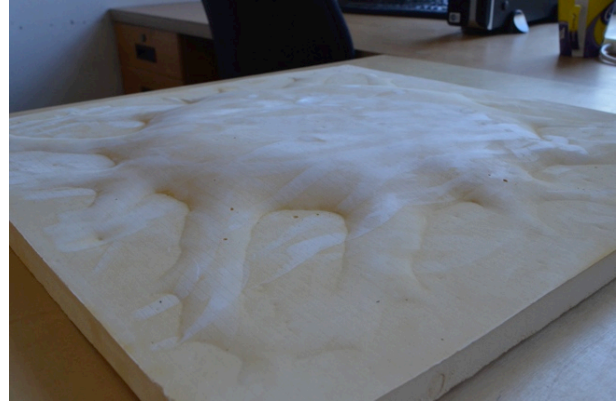

Figure 14: Model b, close up.

Figure 11 and Figure 12 display the plaster model cast without pre-tensioning the fabric. By not applying pre-tension the fabric was free to move when influenced by the weight of the plaster. Figure 12 clearly shows the creases, which formed as a consequence of these movements. In this case the creases appeared in a very unfortunate position structurally. The model shows some deep dents in the base of the cantilevering part of the structure thus reducing the cross-section at the point where the highest moment capacity is needed.

Figure 13 and Figure 14 shows the plaster model in which the fabric was pre-tensioned by hand. This creates a very smooth surface without creases, but because of the pre-tensioning the fabric was not able to sag very deep. Because of the stiff fabric used in the model the finished shape is not very distinct, only the weight of the plaster forces the fabric to deform and stretch into shape.

Both models have their advantages and disadvantages. The aim is to have a model that sags down through the cut-out without making undesired creases.

4 Conclusions

This paper has presented a specialised methodology for calculating and casting an optimised shape using fabric formwork techniques. As part of this methodology a novel software tool was developed. The tool can be used to design optimised shapes that are economical both in manufacturability and material usage. As part of the software a customised topology optimisation algorithm based on known techniques was implemented. The algorithm was customised in such a way that the optimised shapes produced could be cast using fabric formwork techniques.

The case study in this paper concentrates on the design of a slab supported by column in the centre, but the method could without much effort be extended to other types of boundary conditions or other types of elements such as beams or panels.

A verification of the 'cast shape' in terms of a structural and geometric analysis is not performed in this paper. The geometry of the cast shape needs to be compared with the optimised shape to determine the level of approximation in the method and the efficiency and manufacturability of the structure. Furthermore for the structure to be cast at full scale, a detailed structural analysis would be needed. This will be an interesting study for future work.

A few design studies were realised using plaster scale model. These models drew attention to certain characteristics of the method proposed. Using the casting techniques discussed here a compromise between precision and manufacturability has to be made. The optimised shape can be closely approximated when using a fabric not under the influence of pre-stress forces. The shapes created using the non-pre-stress approach closely resemble the optimised shape, but because the fabric is free to crease, undesired aesthetics and structural shapes can emerge. Using an approach with a pre-stressed fabric avoids the creasing but the cast shape is further from the optimised shape. Improving the fabric material model and implementing the hydrostatic forces of the concrete and the cut-out pattern for the formwork as part of the design process could achieve closer approximation of the optimised shape with a pre-stressed design approach.

Overall a good base for a framework for the design and manufacture of optimised shapes cast using fabric formwork has been created, but further validation and improvement of the method is underway.

5 References

BENDSØE, M. P. 1989. Optimal shape design as a material distribution problem. *Structural and multidisciplinary optimization*, 1, 193-202.

CAST. 2011. *Centre for Architectural Structures and Technology* [Online]. Available: http://www.umanitoba.ca/cast_building/ [Accessed October 2011].

DOMBERNOWSKY, P. & SØNDERGAARD, A. 2010. Three-dimensional topology optimisation in architectural and structural design of concrete structures. *Symposium of the International*

Association for Shell and Spatial Structures - IASS Universitat Politècnica de València (UPV): Editorial de la Universitat Politècnica de Valencia.

- GRINSPUN, E., HIRANI, A. N., DESBRUN, M. & SCHRÖDER, P. 2003. Discrete shells. *Proceedings of the 2003 ACM SIGGRAPH/Eurographics symposium on Computer animation*. San Diego, California: Eurographics Association.
- HUANG, X. & XIE, Y. M. 2007. Convergent and mesh-independent solutions for the bi-directional evolutionary structural optimization method. *Finite Elements in Analysis and Design*, 43, 1039-1049.
- HUANG, X., XIE, Y. M. & BURRY, M. C. 2006. A New Algorithm for Bi-Directional Evolutionary Structural Optimization. *JSME International Journal Series C Mechanical Systems, Machine Elements and Manufacturing*, 49, 1091-1099.
- JEPSEN, C. R., KRISTENSEN, M. K. & KIRKEGAARD, P. H. Flexible Mould for Precast Concrete Elements. *International Symposium of the International Association for Shell and Spatial Structures (IASS)*, 2010 Shanghai. China Architecture & Building Press, 2726-2737.
- NEALEN, A., MÜLLER, M., KEISER, R., BOXERMAN, E. & CARLSON, M. 2006. Physically Based Deformable Models in Computer Graphics. *Computer graphics forum*, 25, 809-836.
- QUERIN, O. M., STEVEN, G. P. & XIE, Y. M. 2000. Evolutionary structural optimisation using an additive algorithm. *Finite Elem. Anal. Des.*, 34, 291-308.
- VERLET, L. 1967. Computer "Experiments" on Classical Fluids. I. Thermodynamical Properties of Lennard-Jones Molecules. *Physical Review*, 159, 98.
- VOLINO, P. & MAGNENAT-THALMANN, N. 2001. Comparing Efficiency of Integration Methods for Cloth Simulation. *Proceedings of the International Conference on Computer Graphics*. IEEE Computer Society.
- VOLINO, P. & MAGNENAT-THALMANN, N. 2006. Simple linear bending stiffness in particle systems. *Proceedings of the 2006 ACM SIGGRAPH/Eurographics symposium on Computer animation*. Vienna, Austria: Eurographics Association.
- VOLINO, P., MAGNENAT-THALMANN, N. & FAURE, F. 2009. A simple approach to nonlinear

tensile stiffness for accurate cloth simulation.
ACM Trans. Graph., 28, 1-16.

WEST, M. & ARAYA, R. 2009. Fabric Formwork For Concrete Structures And Architecture. *International Conference on Textile Composites and Inflatable Structures*. Barcelona.

XIE, Y. M. 1993. Simple evolutionary procedure for structural optimization. *Computers & structures*, 49, 885-896.