

# Coprime factorization and robust stabilization for discrete-time infinite-dimensional systems

Ruth F. Curtain\*      Mark R. Opmeer†

Math. Control Signals Systems 23 (2011), no. 1–3, 101–115

## Abstract

We solve the problem of robust stabilization with respect to right-coprime factor perturbations for irrational discrete-time transfer functions. The key condition is that the associated dynamical system and its dual should satisfy a finite-cost condition so that two optimal cost operators exist. We obtain explicit state space formulas for a robustly stabilizing controller in terms of these optimal cost operators and the generating operators of the realization. Along the way we also obtain state space formulas for Bezout factors.

## Keywords:

Robust stabilization; Irrational transfer functions; Infinite-dimensional linear systems; Normalized coprime factorizations; Bezout factors.

## 1 Introduction

The problem of robust stabilization with respect to coprime factor perturbations was first solved in the rational continuous-time case in Glover and McFarlane [9]. The irrational continuous-time case was solved in Georgiou and Smith [8], but in contrast to the work by Glover and McFarlane no state space formulas were given. State space formulas for the irrational continuous-time case were given under increasingly weaker assumptions in Curtain and Zwart [7, Chapter 9.4], Curtain [1], Oostveen [13, Chapter 7] and Curtain [2], [3]. Here we consider the problem for discrete-time infinite-dimensional systems. As in all the above articles, the state space formulas for the robustly stabilizing controller are based on state space formulas for the Nehari problem for a normalized coprime factorization. In the literature these formulas for the solution of the Nehari problem are usually given under the assumption of exponential stabilizability

---

\*Department of Mathematics, University of Groningen, P.O. Box 800, 9700 AV Groningen, The Netherlands.

†Department of Mathematical Sciences, University of Bath, Claverton Down, Bath BA2 7AY, United Kingdom ([m.opmeer@maths.bath.ac.uk](mailto:m.opmeer@maths.bath.ac.uk)).

and detectability, however in [5] we obtained them for discrete-time systems under weaker assumptions. As we did in [4] for the continuous-time case, we also use the state space formulas for the Nehari problem to obtain state space formulas for the Bezout factors of the normalized coprime factorization. The robust stabilization problem is formulated in Section 2. Background results on the suboptimal control problem, normalized factorizations and coprime factorizations for discrete-time infinite-dimensional systems are summarized in Sections 2, 3 and 4, respectively. The formulas for the robustly stabilizing controllers are then derived in Section 6. Various routine calculations have been relegated to the appendix in Section 7.

Finally, we remark that, using the Cayley transform approach as in Opmeer [14, 15], these discrete-time results can be used to obtain explicit formulas for robustly stabilizing controllers with internal loop for continuous-time systems under slightly less restrictive assumptions than those in Curtain [2], [3].

## 2 Formulation of the problem

We consider dynamical systems in discrete-time given by

$$\begin{aligned} x_{n+1} &= Ax_n + Bu_n, & n \in \mathbb{Z}^+ \\ x_0 &= x^0, \\ y_n &= Cx_n + Du_n, & n \in \mathbb{Z}^+, \end{aligned} \tag{1}$$

where  $A \in \mathcal{L}(\mathcal{X})$ ,  $B \in \mathcal{L}(\mathcal{U}, \mathcal{X})$ ,  $C \in \mathcal{L}(\mathcal{X}, \mathcal{Y})$ ,  $D \in \mathcal{L}(\mathcal{U}, \mathcal{Y})$ . Here  $\mathcal{U}$ ,  $\mathcal{X}$  and  $\mathcal{Y}$  are separable Hilbert spaces and e.g.  $\mathcal{L}(\mathcal{X}, \mathcal{Y})$  denotes the Banach space of bounded linear operators from  $\mathcal{X}$  to  $\mathcal{Y}$ . The *transfer function* of such a system is given by

$$\mathbf{G}(z) = D + \sum_{k=0}^{\infty} CA^k Bz^k,$$

for those  $z$  in the largest disc centered at zero for which the series converges. The series converges at least on the disc centered at the origin and with radius  $1/r(A)$ , where  $r(A)$  is the spectral radius of the operator  $A$ , and on that possibly smaller disc the transfer function is alternatively given by  $\mathbf{G}(z) = D + zC(I - zA)^{-1}B$ .

We recall that the Hardy space  $H^\infty(\mathbb{D}; \mathcal{L}(\mathcal{U}, \mathcal{Y}))$  is the space of uniformly bounded analytic functions  $\mathbb{D} \rightarrow \mathcal{L}(\mathcal{U}, \mathcal{Y})$ , where  $\mathbb{D}$  denotes the open unit disc. A system is called *input-output stable* if its transfer function is in  $H^\infty$ . We also recall that a  $H^\infty(\mathbb{D}; \mathcal{L}(\mathcal{U}, \mathcal{Y}))$  function induces a bounded operator from  $H^2(\mathbb{D}; \mathcal{U})$  to  $H^2(\mathbb{D}; \mathcal{Y})$  by multiplication. A system is called *output stable* if its observation Lyapunov equation  $A^*L_cA - L_c + C^*C = 0$  has a nonnegative self-adjoint solution and *input stable* if its control Lyapunov equation  $AL_bA^* - L_b + BB^* = 0$  has a nonnegative self-adjoint solution. The smallest nonnegative self-adjoint solution of the Lyapunov equations are called the *observability Gramian* (denoted by  $L_C$ ) and the *controllability Gramian* (denoted by  $L_B$ ), respectively.

A system is called *exponentially (or power) stable* if the spectral radius of  $A$  is strictly smaller than 1. Exponential stability implies input stability, output stability and input-output stability. Any  $H^\infty$  function has a realization that is input stable, output stable and input-output stable but not necessarily one that is exponentially stable.

The analytic function  $\mathbf{K}$  defined on a neighbourhood of zero and taking values in  $\mathcal{L}(\mathcal{Y}, \mathcal{U})$  is said to stabilize  $\mathbf{G}$  in the input-output sense if  $\begin{bmatrix} I & -\mathbf{K} \\ -\mathbf{G} & I \end{bmatrix}$  has an inverse in  $H^\infty(\mathbb{D}; \mathcal{U} \times \mathcal{Y}, \mathcal{U} \times \mathcal{Y})$ . This inverse is the transfer function from  $\begin{bmatrix} u_1 \\ u_2 \end{bmatrix}$  to  $\begin{bmatrix} e_1 \\ e_2 \end{bmatrix}$  in figure 1. Note that the above condition is equivalent to  $I - \mathbf{K}\mathbf{G}$  being invertible in a neighbourhood of zero and  $(I - \mathbf{K}\mathbf{G})^{-1}$ ,  $\mathbf{G}(I - \mathbf{K}\mathbf{G})^{-1}$ ,  $(I - \mathbf{G}\mathbf{K})^{-1}\mathbf{K}$ ,  $(I - \mathbf{G}\mathbf{K})^{-1}$  being in  $H^\infty$ .

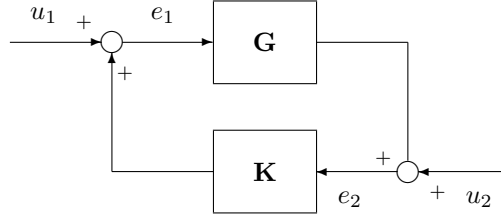

Figure 1: Feedback interconnection of  $\mathbf{G}$  and  $\mathbf{K}$ .

We note the following extension of stabilizing controllers from [6]. The analytic function  $\mathbf{K} = \begin{bmatrix} \mathbf{K}_{11} & \mathbf{K}_{12} \\ \mathbf{K}_{21} & \mathbf{K}_{22} \end{bmatrix}$  defined on a neighbourhood of zero and taking values in  $\mathcal{L}(\mathcal{Y} \times \mathcal{R}, \mathcal{U} \times \mathcal{R})$  where  $\mathcal{R}$  is an additional Hilbert space is said to be a *stabilizing controller with internal loop* for  $\mathbf{G}$  if

$$\begin{bmatrix} I & -\mathbf{K}_{11} & -\mathbf{K}_{12} \\ -\mathbf{G} & I & 0 \\ 0 & -\mathbf{K}_{21} & I - \mathbf{K}_{22} \end{bmatrix},$$

has an inverse in  $H^\infty(\mathbb{D}; \mathcal{U} \times \mathcal{Y} \times \mathcal{R}, \mathcal{U} \times \mathcal{Y} \times \mathcal{R})$ . This inverse is the transfer function from  $[u_1; u_2; u_3]$  to  $[e_1; e_2; e_3]$  in figure 2. If  $I - \mathbf{K}_{22}$  is invertible in a neighbourhood of zero, then the conventional controller  $\mathbf{K}_{11} + \mathbf{K}_{12}(I - \mathbf{K}_{22})^{-1}\mathbf{K}_{21}$  stabilizes  $\mathbf{G}$  if and only if  $\mathbf{K}$  is a stabilizing controller with internal loop for  $\mathbf{G}$ . An advantage of controllers with internal loop over conventional controllers is that an invertibility condition -which is not always satisfied- can be omitted. We refer to [6] for a further discussion of this.

The transfer function  $\mathbf{G}$  is said to have a *right factorization* if there exists a function  $\begin{bmatrix} \mathbf{M} \\ \mathbf{N} \end{bmatrix} \in H^\infty(\mathbb{D}; \mathcal{L}(\mathcal{U}, \mathcal{U} \times \mathcal{Y}))$  such that  $\mathbf{M}(z)$  is invertible in a neighbourhood of zero and  $\mathbf{G}(z) = \mathbf{N}(z)\mathbf{M}(z)^{-1}$  in a neighbourhood of zero. The factorization is called *normalized* when the multiplication operator on  $H^2$  associated with  $\begin{bmatrix} \mathbf{M} \\ \mathbf{N} \end{bmatrix}$  is an isometry (i.e. when  $\begin{bmatrix} \mathbf{M} \\ \mathbf{N} \end{bmatrix}$  is *inner*). The factorization is called *strongly right coprime* if there exists  $[\tilde{\mathbf{X}}, -\tilde{\mathbf{Y}}] \in H^\infty(\mathbb{D}; \mathcal{L}(\mathcal{U} \times \mathcal{Y}, \mathcal{U}))$  such that  $[\tilde{\mathbf{X}}, -\tilde{\mathbf{Y}}]\begin{bmatrix} \mathbf{M} \\ \mathbf{N} \end{bmatrix} = I$  (i.e. when  $\begin{bmatrix} \mathbf{M} \\ \mathbf{N} \end{bmatrix}$  has a left-inverse in  $H^\infty$ ). The function  $[\tilde{\mathbf{X}}, -\tilde{\mathbf{Y}}]$  is called a *Bezout factor* for  $\begin{bmatrix} \mathbf{M} \\ \mathbf{N} \end{bmatrix}$ .

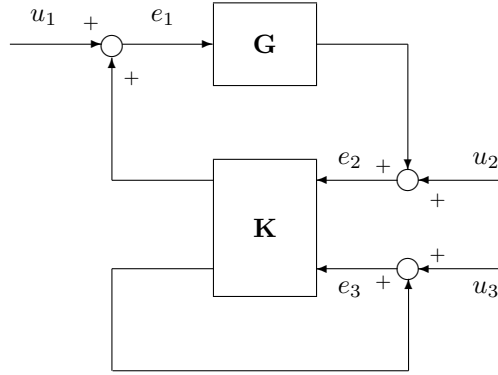

Figure 2: Controller with internal loop

A system is stabilizable in the input-output sense if and only if it has a strongly right coprime factorization ([10], [17] for the case of finite-dimensional input and output spaces; [11] for the general case of possibly infinite-dimensional input and output spaces).

Assume that  $\mathbf{G}$  has a normalized strongly right coprime factor  $\begin{bmatrix} \mathbf{M} \\ \mathbf{N} \end{bmatrix}$ . A transfer function  $\mathbf{G}_\Delta$  is a  $\varepsilon$  right-coprime perturbation of  $\mathbf{G}$  if  $\mathbf{G}_\Delta = (\mathbf{N} + \Delta_{\mathbf{N}})(\mathbf{M} + \Delta_{\mathbf{M}})^{-1}$  with  $\|\Delta\|_{H^\infty} < \varepsilon$  where  $\Delta := \begin{bmatrix} \Delta_{\mathbf{M}} \\ \Delta_{\mathbf{N}} \end{bmatrix}$ . A controller is called robustly stabilizing with respect to right-coprime perturbations with robustness margin  $\varepsilon$  if it stabilizes all  $\varepsilon$ -right-coprime perturbations of  $\mathbf{G}$ . We also use the term  $\varepsilon$ -robustly stabilizing controller. The objective in this article is to find state space formulas for such a robustly stabilizing controller. In the case that  $\mathbf{G}(0) = 0$  we derive explicit formulas for a conventional robustly stabilizing controller. In the case that  $\mathbf{G}(0) \neq 0$  and  $\mathcal{U}$  is finite-dimensional we can also obtain explicit formulas for a conventional robustly stabilizing controller. When  $\mathbf{G}(0) \neq 0$  and  $\mathcal{U}$  is infinite-dimensional it is not clear whether a conventional robustly stabilizing controller exists. However, we do obtain explicit formulas for a robustly stabilizing controller with internal loop.

### 3 The suboptimal Nehari problem

The following main result of [5] is crucial to the results in this article as it forms the basis for all the state space formulas given here.

**Theorem 1.** *Assume that  $\begin{bmatrix} A_F & B_F \\ C_F & D_F \end{bmatrix}$  is input stable, output stable and input-output stable. Let  $\mathbf{F}$  denote the transfer function and  $L_B$  and  $L_C$  the controllability and observability Gramian respectively. Let  $\sigma > \sqrt{r(L_B L_C)}$ , where  $r(L_B L_C)$  is the spectral radius of the product  $L_B L_C$ , be given. Define  $\mathbf{L}$  as the transfer function of the system*

$$\begin{bmatrix} A_L & B_L \\ C_L & D_L \end{bmatrix} := \begin{bmatrix} A_W & -A_W W C_F^* \\ B_F^* L_C A_W & -D_F^* - B_F^* L_C A_W W C_F^* \end{bmatrix},$$

with  $A_W = A_F(I + WC_F^*C_F)^{-1}$  and  $W = (\sigma^2I - L_B L_C)^{-1}L_B$ . Then

$$\sup_{|z|=1} \|\mathbf{F}(z) + \mathbf{L}(z)^*\| \leq \sigma.$$

## 4 Normalized factorizations

In [4] we obtained the continuous-time analogues of the results reviewed in this section on normalized factorizations. The discrete-time results presented here can be proven similarly (details are given in [15] and [16]).

To the dynamical system (1) we associate the *finite cost condition*: for all  $x^0 \in \mathcal{X}$  there exists a  $u \in \ell^2(\mathbb{Z}^+; \mathcal{U})$  such that  $y \in \ell^2(\mathbb{Z}^+; \mathcal{Y})$ . Under this condition, for each  $x^0 \in \mathcal{X}$ , there exists an optimal control  $u^{\text{opt}}$  with corresponding output  $y^{\text{opt}}$  minimizing the cost function  $\| \begin{bmatrix} u \\ y \end{bmatrix} \|_{\ell^2(\mathbb{Z}^+; \mathcal{U} \times \mathcal{Y})}^2$  and a nonnegative, self-adjoint operator  $Q$  such that  $\| \begin{bmatrix} u^{\text{opt}} \\ y^{\text{opt}} \end{bmatrix} \|_{\ell^2}^2 = \langle Qx^0, x^0 \rangle$ . This operator  $Q$  is the smallest nonnegative self-adjoint solution of the *control algebraic Riccati equation*

$$A^*QA - Q + C^*C - (C^*D + A^*QB)(I + D^*D + B^*QB)(D^*C + B^*QA) = 0.$$

The corresponding closed-loop system

$$\left[ \begin{array}{c|c} A_F & B_F \\ \hline C_F & D_F \end{array} \right] := \left[ \begin{array}{c|c} A + BF & BS^{-1/2} \\ \hline F & S^{-1/2} \\ C + DF & DS^{-1/2} \end{array} \right], \quad (2)$$

with

$$S := I + D^*D + B^*QB, \quad F := -S^{-1}(D^*C + B^*QA), \quad (3)$$

is a state space realization of a normalized right factorization of  $\mathbf{G}$ . The observability gramian  $L_C$  of this closed-loop system equals the optimal cost operator  $Q$ . The closed-loop system (2) is output stable and input-output stable (but it is not necessarily input stable). Its transfer function provides a weakly right coprime factorization of the transfer function of  $\begin{bmatrix} A & B \\ C & D \end{bmatrix}$  (see [12]), but not necessarily a strongly right coprime one. In the next section we discuss an assumption that does guarantee input stability and strong right coprimeness.

## 5 Coprime factorizations

The *dual finite cost condition* is the condition that the finite cost condition holds for the dynamical system

$$\begin{aligned} x_{n+1} &= A^*x_n + C^*u_n, & n \in \mathbb{Z}^+ \\ x_0 &= x^0, \\ y_n &= B^*x_n + D^*u_n, & n \in \mathbb{Z}^+. \end{aligned}$$

We denote the optimal cost operator of this dual system by  $P$ . This operator  $P$  is the smallest nonnegative self-adjoint solution of the *filter algebraic Riccati equation*

$$APA^* - P + BB^* - (BD^* + APC^*)(I + DD^* + CPC^*)(DB^* + CPA^*) = 0.$$

For the observability and controllability gramian of the closed-loop system (2) we have respectively,  $L_C = Q$  and  $L_B = (I + PQ)^{-1}P$ . It follows that, when both the finite cost condition and the dual finite cost condition hold, the closed-loop system (2) is not only output stable and input-output stable but also input stable. Moreover,  $r(L_B L_C) = r((I + PQ)^{-1}PQ) < 1$ . Proofs of the above statements can be found in [16] or [15]. (In [16, Lemma 6.9] an additional controllability assumption is made to obtain  $L_B = (I + PQ)^{-1}P$ , but this condition is superfluous as shown in [15, Proposition 6.43]. The argument there is essentially the same as was used in continuous-time in [12, Lemma 4.9]).

Denote the normalized right factor that is the transfer function of the closed-loop system (2) by  $\mathbf{F} = \begin{bmatrix} \mathbf{M} \\ \mathbf{N} \end{bmatrix}$ . Under the assumption that both the finite cost condition and the dual finite cost condition hold, applying Theorem 1 we conclude that for any  $\sigma$  with  $r((I + PQ)^{-1}PQ) < \sigma < 1$  there exists a  $\mathbf{L} \in H^\infty(\mathbb{D}; \mathcal{L}(\mathcal{U} \times \mathcal{Y}, \mathcal{U}))$  with

$$\|\mathbf{F} - \mathbf{L}^*\|_\infty = \left\| \begin{bmatrix} \mathbf{M} \\ \mathbf{N} \end{bmatrix} - \mathbf{L}^* \right\|_\infty \leq \sigma < 1,$$

and  $\mathbf{L}$  has a realization

$$\begin{aligned} A_L &:= A_W, \\ B_L &:= [-A_W W F^*, -A_W W (C^* + F^* D^*)], \\ C_L &:= S^{-1/2} B^* Q A_W, \\ D_L &:= [-S^{-1/2} (I + B^* Q A_W W F^*), -S^{-1/2} (D^* + B^* Q A_W W (C^* + F^* D^*))], \end{aligned} \tag{4}$$

where we use the notation of (2) and (3).

Noting that  $\mathbf{F}^* \mathbf{F} = I$  by the normalization condition we obtain

$$\|I + \mathbf{L}\mathbf{F}\|_{H^\infty} = \|\mathbf{F}^* \mathbf{F} + \mathbf{L}\mathbf{F}\|_{L^\infty} \leq \|\mathbf{F}^* + \mathbf{L}\|_{L^\infty} \|\mathbf{F}\|_{L^\infty} = \|\mathbf{F} + \mathbf{L}^*\|_{L^\infty} < 1.$$

Since  $H^\infty(\mathbb{D}; \mathcal{L}(\mathcal{U}))$  is a Banach algebra, it follows from the Neumann series that  $\mathbf{L}\mathbf{F}$  has an inverse in  $H^\infty(\mathbb{D}; \mathcal{L}(\mathcal{U}))$ . Hence  $(\mathbf{L}\mathbf{F})^{-1} \mathbf{L}\mathbf{F} = I$ , and  $\mathbf{F}$  has a left-inverse in  $H^\infty(\mathbb{D}; \mathcal{L}(\mathcal{U} \times \mathcal{Y}, \mathcal{U}))$ , namely  $(\mathbf{L}\mathbf{F})^{-1} \mathbf{L}$ . In other words,  $[\tilde{\mathbf{X}}, -\tilde{\mathbf{Y}}] := (\mathbf{L} \begin{bmatrix} \mathbf{M} \\ \mathbf{N} \end{bmatrix})^{-1} \mathbf{L}$  is a Bezout factor for  $\begin{bmatrix} \mathbf{M} \\ \mathbf{N} \end{bmatrix}$ . From the state space formulas for  $\mathbf{L}$  given by Theorem 1 and the state space formulas (2) for the normalized right factor, state space formulas for the Bezout factors can be obtained as (see Corollary 10 in the appendix):

$$\begin{aligned} \underline{A} &= A_W + (I + A_W W A_F^* Q) B [I + D^* D - B^* Q A_W W A_F^* Q B]^{-1} B^* Q A_W, \\ \underline{B} &= -A_W W [F^*, C^* + F^* D^*] \\ &\quad - (I + A_W W A_F^* Q) B [I + D^* D - B^* Q A_W W A_F^* Q B]^{-1} ([I, D^*] + B^* Q A_W W [F^*, C^* + F^* D^*]), \\ \underline{C} &= -S^{1/2} [I + D^* D - B^* Q A_W W A_F^* Q B]^{-1} B^* Q A_W, \\ \underline{D} &= S^{1/2} [I + D^* D - B^* Q A_W W A_F^* Q B]^{-1} ([I, D^*] + B^* Q A_W W [F^*, C^* + F^* D^*]), \end{aligned}$$

where

$$\begin{aligned} A_F &= A + BF, \\ E_\sigma &:= \sigma^2 I + (\sigma^2 - 1)PQ, \\ W &= E_\sigma^{-1}P, \\ A_W &= A_F(E_\sigma + P(C^*C + F^*SF))^{-1}E_\sigma, \end{aligned}$$

and  $S$  and  $F$  are as in (3). This gives the following theorem.

**Theorem 2.** *Assume that  $\begin{bmatrix} A & B \\ C & D \end{bmatrix}$  with transfer function  $\mathbf{G}$  satisfies the finite cost condition and the dual finite cost condition. Then the transfer function of the system (2) is a normalized strongly right coprime factorization of  $\mathbf{G}$ . The transfer function of the system  $\begin{bmatrix} A & B \\ C & D \end{bmatrix}$  given above is a Bezout factor for this factorization.*

*Proof.* That the transfer function is a normalized strongly right coprime factorization was proven as mentioned above in [16] and also in [15]. The statement on the Bezout factor is proven as Corollary 10 in the appendix.  $\square$

By duality, under the conditions of Theorem 2,  $\mathbf{G}$  also has a normalized strongly left coprime factorization  $[\tilde{\mathbf{M}}, \tilde{\mathbf{N}}]$ . In the following lemma we provide a result on a function obtained from the normalized strongly left and right coprime factorizations that will be used in the proof of existence of robustly stabilizing controllers.

**Lemma 3.** *Assume that  $\mathbf{G}$  has a strongly right coprime factorization  $\begin{bmatrix} \mathbf{M} \\ \mathbf{N} \end{bmatrix}$  and a strongly left coprime factorization  $[\tilde{\mathbf{M}}, \tilde{\mathbf{N}}]$ . Define  $\mathbf{W}$  almost everywhere on the unit circle by*

$$\mathbf{W}(z) := \begin{bmatrix} \mathbf{M}(z) & -\tilde{\mathbf{N}}(z)^* \\ \mathbf{N}(z) & \tilde{\mathbf{M}}(z)^* \end{bmatrix}.$$

*Then  $\mathbf{W}(z)$  is unitary for almost all  $z$  on the unit circle.*

*Proof.* We first show that  $\mathbf{W}(z)$  is an isometry, i.e. that  $\mathbf{W}(z)^*\mathbf{W}(z) = I$  for almost all  $z$  on the unit circle. We have

$$\begin{aligned} \mathbf{W}(z)^*\mathbf{W}(z) &= \begin{bmatrix} \mathbf{M}(z)^* & \mathbf{N}(z)^* \\ -\tilde{\mathbf{N}}(z) & \tilde{\mathbf{M}}(z) \end{bmatrix} \begin{bmatrix} \mathbf{M}(z) & -\tilde{\mathbf{N}}(z)^* \\ \mathbf{N}(z) & \tilde{\mathbf{M}}(z)^* \end{bmatrix} \\ &= \begin{bmatrix} \mathbf{M}(z)^*\mathbf{M}(z) + \mathbf{N}(z)^*\mathbf{N}(z) & \mathbf{N}(z)^*\tilde{\mathbf{M}}(z)^* - \mathbf{M}(z)^*\tilde{\mathbf{N}}(z)^* \\ \tilde{\mathbf{M}}(z)\mathbf{N}(z) - \tilde{\mathbf{N}}(z)\mathbf{M}(z) & \tilde{\mathbf{M}}(z)\tilde{\mathbf{M}}(z)^* + \tilde{\mathbf{N}}(z)\tilde{\mathbf{N}}(z)^* \end{bmatrix}. \end{aligned}$$

The diagonal entries equal the identity since both the right and the left factorization is normalized. The off-diagonal entries are zero by the fact that  $\mathbf{G} = \mathbf{N}\mathbf{M}^{-1} = \tilde{\mathbf{M}}^{-1}\tilde{\mathbf{N}}$  in a neighbourhood of zero so that  $\tilde{\mathbf{N}}\mathbf{M} = \tilde{\mathbf{M}}\mathbf{N}$  in a neighbourhood of zero which by analyticity on the open unit disc, the identity theorem and nontangential limits implies equality on the unit circle. We show

that  $\mathbf{W}(z)$  is surjective. Since a surjective isometry is unitary, this will complete the proof of the lemma. We use that an operator is surjective if and only if its range is closed and its adjoint is injective. As is well-known, the range of any isometry is closed. So it remains to show that  $\mathbf{W}(z)^*$  is injective. It is well-known [7, Lemma A.7.44] that Bezout factors can be chosen so that

$$\begin{bmatrix} \mathbf{M} & \mathbf{Y} \\ \mathbf{N} & \mathbf{X} \end{bmatrix} = \begin{bmatrix} \tilde{\mathbf{X}} & -\tilde{\mathbf{Y}} \\ -\tilde{\mathbf{N}} & \tilde{\mathbf{M}} \end{bmatrix}^{-1}. \quad (5)$$

We use (5) and the normalization property to obtain

$$\begin{aligned} [\mathbf{M}^*, \mathbf{N}^*] &= [\mathbf{M}^*, \mathbf{N}^*] \begin{bmatrix} \mathbf{M} & \mathbf{Y} \\ \mathbf{N} & \mathbf{X} \end{bmatrix} \begin{bmatrix} \tilde{\mathbf{X}} & -\tilde{\mathbf{Y}} \\ -\tilde{\mathbf{N}} & \tilde{\mathbf{M}} \end{bmatrix} = [I, \mathbf{M}^*\mathbf{Y} + \mathbf{N}^*\mathbf{X}] \begin{bmatrix} \tilde{\mathbf{X}} & -\tilde{\mathbf{Y}} \\ -\tilde{\mathbf{N}} & \tilde{\mathbf{M}} \end{bmatrix} \\ &= [\tilde{\mathbf{X}} - \mathbf{M}^*\mathbf{Y}\tilde{\mathbf{N}} - \mathbf{N}^*\mathbf{X}\tilde{\mathbf{N}}, -\tilde{\mathbf{Y}} + \mathbf{M}^*\mathbf{Y}\tilde{\mathbf{M}} + \mathbf{N}^*\mathbf{X}\tilde{\mathbf{M}}], \end{aligned} \quad (6)$$

on the unit circle. Suppose that  $[u; y] \in \ker \mathbf{W}(z)^*$ . Then  $\mathbf{M}^*u + \mathbf{N}^*y = 0$  and  $-\tilde{\mathbf{N}}u + \tilde{\mathbf{M}}y = 0$ . Multiplying (6) by  $[u; y]$  we obtain  $0 = \tilde{\mathbf{X}}u - \tilde{\mathbf{Y}}y$ . Hence

$$\begin{bmatrix} \tilde{\mathbf{X}} & -\tilde{\mathbf{Y}} \\ -\tilde{\mathbf{N}} & \tilde{\mathbf{M}} \end{bmatrix} \begin{bmatrix} u \\ y \end{bmatrix} = 0.$$

Using (5) we obtain  $[u; y] = 0$ . It follows that  $\mathbf{W}(z)^*$  is injective, which completes the proof.  $\square$

## 6 Robustly stabilizing controllers

The following theorem relates robustly stabilizing controllers to the Nehari problem.

**Theorem 4.** *Suppose that  $\begin{bmatrix} \mathbf{M} \\ \mathbf{N} \end{bmatrix}$  is a normalized strongly right coprime factor of  $\mathbf{G}$  and that  $\varepsilon \in (0, 1)$ . If there exists a  $[\tilde{\mathbf{V}}, \tilde{\mathbf{U}}] \in H^\infty(\mathbb{D}; \mathcal{L}(\mathcal{U} \times \mathcal{Y}, \mathcal{U}))$  that satisfies*

$$\left\| \begin{bmatrix} \mathbf{M} \\ \mathbf{N} \end{bmatrix} + \begin{bmatrix} -\tilde{\mathbf{V}}^* \\ \tilde{\mathbf{U}}^* \end{bmatrix} \right\| \leq \sqrt{1 - \varepsilon^2},$$

then  $\mathbf{K} := \begin{bmatrix} 0 & I \\ \tilde{\mathbf{U}} & I - \tilde{\mathbf{V}} \end{bmatrix}$  is an  $\varepsilon$ -robustly stabilizing controller with internal loop for  $\mathbf{G}$ .

*Proof.* Let  $\mathbf{G}_\Delta$  be a  $\varepsilon$  right-coprime perturbation of  $\mathbf{G}$ ; i.e.  $\mathbf{G} = (\mathbf{N} + \Delta_{\mathbf{N}})(\mathbf{M} + \Delta_{\mathbf{M}})^{-1}$  with  $\|\Delta\|_{H^\infty} < \varepsilon$  where  $\Delta := \begin{bmatrix} \Delta_{\mathbf{M}} \\ \Delta_{\mathbf{N}} \end{bmatrix}$ .

It follows from [6, Theorem 4.2] (that article is for continuous-time systems, but the discrete-time proof is identical) that  $\mathbf{K}$  is a stabilizing controller with internal loop for  $\mathbf{G}_\Delta$  if and only if  $\tilde{\mathbf{V}}\mathbf{M}_\Delta - \tilde{\mathbf{U}}\mathbf{N}_\Delta$  has an inverse in  $H^\infty$ .

Let  $\mathbf{W} : \mathbb{T} \rightarrow \mathcal{L}(\mathcal{U} \times \mathcal{Y})$  be the function from Lemma 3, i.e.,

$$\mathbf{W}(z) = \begin{bmatrix} \mathbf{M}(z) & -\tilde{\mathbf{N}}(z)^* \\ \mathbf{N}(z) & \tilde{\mathbf{M}}(z)^* \end{bmatrix}.$$



Define  $\mathbf{P} \in L^\infty(\mathbb{T}, \mathcal{L}(\mathcal{U} \times \mathcal{Y}, \mathcal{U}))$  by

$$\mathbf{P} := \left( [\mathbf{M}^*, \mathbf{N}^*] + [-\tilde{\mathbf{V}}, \tilde{\mathbf{U}}] \right) \mathbf{W} = [I - \tilde{\mathbf{V}}\mathbf{M} + \tilde{\mathbf{U}}\mathbf{N}, \tilde{\mathbf{V}}\tilde{\mathbf{N}}^* + \tilde{\mathbf{U}}\tilde{\mathbf{M}}^*]. \quad (7)$$

Since  $\mathbf{W}(z)$  is unitary we have

$$\|\mathbf{P}\|_\infty \leq \sqrt{1 - \varepsilon^2}.$$

It follows that  $\|I - \tilde{\mathbf{V}}\mathbf{M} + \tilde{\mathbf{U}}\mathbf{N}\|_\infty < 1$ . Since  $H^\infty(\mathbb{D}, \mathcal{L}(\mathcal{U}))$  is a Banach algebra, it follows that  $\tilde{\mathbf{V}}\mathbf{M} - \tilde{\mathbf{U}}\mathbf{N}$  has an inverse in  $H^\infty(\mathbb{D}, \mathcal{L}(\mathcal{U}))$ . Hence  $\mathbf{K}$  is a stabilizing controller with internal loop for  $\mathbf{G}$ .

Denote  $\Delta := [\Delta_{\mathbf{M}}; \Delta_{\mathbf{N}}] = [\mathbf{M}_\Delta; \mathbf{N}_\Delta] - [\mathbf{M}; \mathbf{N}]$ . Then we have

$$\tilde{\mathbf{V}}\mathbf{M}_\Delta - \tilde{\mathbf{U}}\mathbf{N}_\Delta = \tilde{\mathbf{V}}\mathbf{M} - \tilde{\mathbf{U}}\mathbf{N} + [\tilde{\mathbf{V}}, -\tilde{\mathbf{U}}]\Delta = \left( \tilde{\mathbf{V}}\mathbf{M} - \tilde{\mathbf{U}}\mathbf{N} \right) (I + \mathbf{S}\Delta),$$

where

$$\mathbf{S} := (\tilde{\mathbf{V}}\mathbf{M} - \tilde{\mathbf{U}}\mathbf{N})^{-1}[\tilde{\mathbf{V}}, -\tilde{\mathbf{U}}].$$

It follows as before from [6, Theorem 4.2] that  $\mathbf{K}$  is a stabilizing controller with internal loop for  $\mathbf{G}_\Delta$  if and only if  $I + \mathbf{S}\Delta$  has an inverse in  $H^\infty(\mathbb{D}, \mathcal{L}(\mathcal{U}))$ . The latter is true if  $\|\mathbf{S}\|_\infty < 1/\varepsilon$ . Using the fact that  $\mathbf{W}$  is unitary, we have

$$\begin{aligned} \|\mathbf{S}\|_\infty^2 &= \|\mathbf{S}\mathbf{W}\|_\infty^2 = \|[I, -(\tilde{\mathbf{V}}\mathbf{M} - \tilde{\mathbf{U}}\mathbf{N})^{-1}(\tilde{\mathbf{V}}\tilde{\mathbf{N}}^* + \tilde{\mathbf{U}}\tilde{\mathbf{M}}^*)]\|_\infty^2 \\ &= 1 + \|(\tilde{\mathbf{V}}\mathbf{M} - \tilde{\mathbf{U}}\mathbf{N})^{-1}(\tilde{\mathbf{V}}\tilde{\mathbf{N}}^* + \tilde{\mathbf{U}}\tilde{\mathbf{M}}^*)\|_\infty^2 = 1 + \|(I - \mathbf{P}_1)^{-1}\mathbf{P}_2\|_\infty^2, \end{aligned}$$

where  $\mathbf{P} = [\mathbf{P}_1, \mathbf{P}_2]$  is the function from (7). From Lemma 5 below we obtain

$$\|\mathbf{S}\|_\infty^2 \leq \frac{1}{\varepsilon^2},$$

as desired. So  $\mathbf{K}$  is an  $\varepsilon$ -robustly stabilizing controller with internal loop for  $\mathbf{G}$ .  $\square$

The following elementary lemma was used in the proof of Theorem 4.

**Lemma 5.** *If in a Banach algebra we have  $\|x\|^2 + \|y\|^2 \leq \alpha^2 < 1$ , then  $I - y$  is invertible and  $\|(I - y)^{-1}x\|^2 \leq \alpha^2/(1 - \alpha^2)$ .*

*Proof.* That  $I - y$  has a bounded inverse follows from the Neumann series theorem. From this theorem we also obtain  $\|(I - y)^{-1}\| \leq 1/(1 - \|y\|)$ . It follows that  $\|(I - y)^{-1}x\|^2 \leq \|x\|^2/(1 - \|y\|)^2$ . Denote  $x_1 := \|x\|$  and  $y_1 := \|y\|$ . Using elementary vector calculus one sees that the function  $x_1^2/(1 - y_1)^2$  under the constraint  $x_1^2 + y_1^2 \leq \alpha^2 < 1$  has the maximum  $(\alpha^2 - \alpha^4)/(1 - \alpha^2)$ . The desired result follows.  $\square$

Combining Theorem 4 with the results mentioned earlier in the article gives the following theorem that provides state space formulas for a robustly stabilizing controller.

**Theorem 6.** Suppose that  $\begin{bmatrix} A & B \\ C & D \end{bmatrix}$  satisfies the finite cost condition and the dual finite cost condition. Denote the optimal cost operator and the dual optimal cost operator by  $Q$  and  $P$ , respectively and the closed-loop system (2) by  $\begin{bmatrix} A_F & B_F \\ C_F & D_F \end{bmatrix}$ . Let  $\sigma$  be such that  $r((I + PQ)^{-1}PQ) < \sigma < 1$  and  $\mathbf{L} := [-\tilde{\mathbf{V}}, \tilde{\mathbf{U}}]$  the solution of the Nehari problem with parameter  $\sigma$  given by Theorem 1.

Then  $\mathbf{K} := \begin{bmatrix} 0 & I \\ \tilde{\mathbf{U}} & I - \tilde{\mathbf{V}} \end{bmatrix}$  is a  $\sqrt{1 - \sigma^2}$ -robustly stabilizing controller with internal loop for the transfer function of  $\begin{bmatrix} A & B \\ C & D \end{bmatrix}$ . If  $I + B^*QA_WWF^*$  (or equivalently  $I + A_WWF^*B^*Q$ ) is invertible then a  $\sqrt{1 - \sigma^2}$ -robustly stabilizing conventional controller is given by the state space formulas:

$$\begin{aligned} \tilde{A} &= (I + A_WWF^*B^*Q)^{-1}A_W, \\ \tilde{B} &= -(I + A_WWF^*B^*Q)^{-1}A_WWC^*, \\ \tilde{C} &= -(I + B^*QA_WWF^*)^{-1}B^*QA_W, \\ \tilde{D} &= D^* + (I + B^*QA_WWF^*)^{-1}B^*QA_WWC^*. \end{aligned}$$

In particular, this invertibility condition is satisfied when  $D = 0$ .

*Proof.* That the given  $\mathbf{K}$  is a robustly stabilizing controller with internal loop follows immediately from Theorem 4 and the existence of the solution to the Nehari problem from Theorem 1.

The invertibility assumption of the theorem is equivalent to invertibility of  $\tilde{\mathbf{V}}$  in a neighbourhood of zero, so by the general correspondence between controllers with internal loop and conventional controllers under an invertibility condition that was mentioned in Section 2,  $\tilde{\mathbf{V}}^{-1}\tilde{\mathbf{U}}$  is a  $\sqrt{1 - \sigma^2}$ -robustly stabilizing conventional controller. That the given formulas are state space formulas for  $\tilde{\mathbf{V}}^{-1}\tilde{\mathbf{U}}$  is proven as Corollary 12 in the appendix.

To see that the invertibility condition is satisfied when  $D = 0$  we argue as follows. By the proof of Theorem 4,  $\tilde{\mathbf{V}}\mathbf{M} - \tilde{\mathbf{U}}\mathbf{N}$ , with  $\begin{bmatrix} \mathbf{M} \\ \mathbf{N} \end{bmatrix}$  being the transfer function of (2), has an inverse in  $H^\infty(\mathbb{D}, \mathcal{L}(\mathcal{U}))$ . In particular,  $(\tilde{\mathbf{V}}\mathbf{M} - \tilde{\mathbf{U}}\mathbf{N})(0)$  has an inverse in  $\mathcal{L}(\mathcal{U})$ . If  $D = 0$ , then it is seen from (2) that  $\mathbf{N}(0) = 0$ . So  $(\tilde{\mathbf{V}}\mathbf{M} - \tilde{\mathbf{U}}\mathbf{N})(0) = \tilde{\mathbf{V}}(0)\mathbf{M}(0)$ . It follows that  $\tilde{\mathbf{V}}(0)\mathbf{M}(0)$  is invertible and, since  $\mathbf{M}(0)$  is invertible, it follows that  $\tilde{\mathbf{V}}(0)$  is. From this it follows that  $\tilde{\mathbf{V}}$  is invertible in a neighbourhood of zero. That in turn is equivalent to the invertibility conditions mentioned in the theorem.  $\square$

We note that the Bezout factors from Theorem 2 are the ones such that  $\tilde{\mathbf{X}}^{-1}\tilde{\mathbf{Y}}$  equals the robustly stabilizing controller from Theorem 6.

*Remark 7.* We note that invertibility of  $\tilde{\mathbf{V}}$  in a neighbourhood of zero can be guaranteed by replacing  $\tilde{\mathbf{V}}$  by  $\delta I_{\mathcal{U}} + \tilde{\mathbf{V}}$  with  $\delta$  such that  $-\delta \notin \sigma(\tilde{\mathbf{V}}(0))$ . If  $\mathcal{U}$  is finite-dimensional, then such a  $\delta$  may be chosen positive and arbitrarily small. It follows that if  $\mathcal{U}$  is finite-dimensional, replacing  $\tilde{\mathbf{V}}$  by  $\delta I_{\mathcal{U}} + \tilde{\mathbf{V}}$  leads to a conventional robustly stabilizing controller with robustness margin arbitrarily close to the desired  $\sqrt{1 - \sigma^2}$ . In the state space formulas this corresponds to replacing  $I + A_WWF^*B^*Q$  and  $I + B^*QA_WWF^*$  by  $\eta I + A_WWF^*B^*Q$  and  $\eta I + B^*QA_WWF^*$  respectively where  $\eta$  is chosen close to 1. So at least in the

case where  $\mathcal{U}$  is finite-dimensional, controllers with internal loop can be avoided by slightly tweaking the formulas.

## 7 Appendix: Calculation of state space formulas

The following elementary lemma is very useful in streamlining the calculations in this appendix.

**Lemma 8.** *Assume that  $\begin{bmatrix} A_T & B_T \\ C_T & D_T \end{bmatrix}$  and  $\begin{bmatrix} A_R & B_R \\ C_R & D_R \end{bmatrix}$  are two systems with  $\mathcal{U}_T = \mathcal{Y}_R$  and that satisfy  $A_T - B_T C_R = A_R$  and  $C_T = D_T C_R$ . Denote the transfer functions by  $\mathbf{T}$  and  $\mathbf{R}$  respectively. Then  $\begin{bmatrix} A_T & B_R + B_T D_R \\ C_T & D_T D_R \end{bmatrix}$  is a realization of  $\mathbf{TR}$ .*

*Proof.* We have for  $s$  of sufficiently large modulus

$$\begin{aligned} \mathbf{T} \begin{pmatrix} 1 \\ s \end{pmatrix} \mathbf{R} \begin{pmatrix} 1 \\ s \end{pmatrix} &= [C_T(sI - A_T)^{-1}B_T + D_T] [C_R(sI - A_R)^{-1}B_R + D_R] \\ &= C_T(sI - A_T)^{-1}B_T C_R(sI - A_R)^{-1}B_R + C_T(sI - A_T)^{-1}B_T D_R + D_T C_R(sI - A_R)^{-1}B_R + D_T D_R \\ &= C_T(sI - A_T)^{-1}B_T C_R(sI - A_R)^{-1}B_R + C_T(sI - A_T)^{-1}B_T D_R + C_T(sI - A_R)^{-1}B_R + D_T D_R \\ &= C_T(sI - A_T)^{-1} [B_T C_R + sI - A_T] (sI - A_R)^{-1}B_R + C_T(sI - A_T)^{-1}B_T D_R + D_T D_R \\ &= C_T(sI - A_T)^{-1} [sI - A_R] (sI - A_R)^{-1}B_R + C_T(sI - A_T)^{-1}B_T D_R + D_T D_R \\ &= C_T(sI - A_T)^{-1}B_R + C_T(sI - A_T)^{-1}B_T D_R + D_T D_R \\ &= C_T(sI - A_T)^{-1} [B_R + B_T D_R] + D_T D_R. \end{aligned}$$

With  $z = \frac{1}{s}$  and using the identity theorem we obtain that  $\mathbf{TR}$  equals the transfer function of the given system.  $\square$

**Lemma 9.** *Assume that  $\begin{bmatrix} A_E & B_E \\ C_E & D_E \end{bmatrix}$  and  $\begin{bmatrix} A_F & B_F \\ C_F & D_F \end{bmatrix}$  are two systems with  $\mathcal{U}_E = \mathcal{Y}_F$  and such that  $A_E - B_E C_F = A_F$  and  $C_E = D_E C_F$ . Further assume that  $D_E D_F$  is invertible. Denote the transfer functions by  $\mathbf{E}$  and  $\mathbf{F}$  respectively. Then  $\mathbf{EF}$  is invertible in a neighbourhood of zero and a realization of  $(\mathbf{EF})^{-1}\mathbf{E}$  is*

$$\begin{bmatrix} A_E - (B_F + B_E D_F)(D_E D_F)^{-1}C_E & B_E - (B_F + B_E D_F)(D_E D_F)^{-1}D_E \\ (D_E D_F)^{-1}C_E & (D_E D_F)^{-1}D_E \end{bmatrix}.$$

*Proof.* It follows from Lemma 8 that  $\mathbf{EF}$  has realization

$$\begin{bmatrix} A_E & B_F + B_E D_F \\ C_E & D_E D_F \end{bmatrix}.$$

It then follows that  $(\mathbf{EF})^{-1}$  has realization

$$\begin{bmatrix} A_T & B_T \\ C_T & D_T \end{bmatrix} = \begin{bmatrix} A_E - (B_F + B_E D_F)(D_E D_F)^{-1}C_E & -(B_F + B_E D_F)(D_E D_F)^{-1} \\ (D_E D_F)^{-1}C_E & (D_E D_F)^{-1} \end{bmatrix}.$$

This realization together with the realization of  $\mathbf{E}$  again satisfies the assumptions of Lemma 8 and application of that lemma gives the desired result.  $\square$

**Corollary 10.** *The transfer function of  $\begin{bmatrix} A & B \\ C & D \end{bmatrix}$  is a Bezout factor as claimed in Theorem 2.*

*Proof.* Recall from the paragraph leading up to the statement of Theorem 2 that a Bezout factor is  $(\mathbf{LF})^{-1}\mathbf{L}$ , where  $\mathbf{F}$  is the transfer function of the system  $\begin{bmatrix} A_F & B_F \\ C_F & D_F \end{bmatrix}$  (system (2)) and  $\mathbf{L}$  the transfer function of the system (4). So it remains to show that the transfer function of  $\begin{bmatrix} A & B \\ C & D \end{bmatrix}$  equals  $(\mathbf{LF})^{-1}\mathbf{L}$ . This follows from a application of Lemma 9 with  $\begin{bmatrix} A_F & B_F \\ C_F & D_F \end{bmatrix}$  the system (2) and  $\begin{bmatrix} A_E & B_E \\ C_E & D_E \end{bmatrix}$  the system  $\begin{bmatrix} A_L & B_L \\ C_L & D_L \end{bmatrix}$  given by (4). We verify the details. The conditions on the state space parameters needed to apply Lemma 9 are checked as follows.

We have

$$A_E - B_EC_F = A_L - B_L C_F = A_W + A_W W C_F^* C_F = A_W(I + W C_F^* C_F) = A_F.$$

We further have

$$D_EC_F = D_L C_F = -D_F^* C_F - B_F^* L_C A_W W C_F^* C_F,$$

and using the above established  $A_W W C_F^* C_F = A_F - A_W$  this equals

$$-D_F^* C_F - B_F^* L_C A_F + B_F^* L_C A_W.$$

Now  $C_E = C_L = B_F^* L_C A_W$  and so it remains to show that  $D_F^* C_F + B_F^* L_C A_F = 0$ . Substituting from (2) and using that the fact that the observability gramian  $L_C$  of the closed-loop system equals the smallest nonnegative self-adjoint solution  $Q$  of the control Riccati equation gives:

$$\begin{aligned} D_F^* C_F + B_F^* L_C A_F &= S^{-1/2} (F + D^* C + D^* D F + B^* Q A + B^* Q B F) \\ &= S^{-1/2} (D^* C + B^* Q A) + S^{-1/2} (I + D^* D + B^* Q B) F. \end{aligned}$$

Using the definition of  $S$  from (3) this equals

$$S^{-1/2} (D^* C + B^* Q A) + S^{1/2} F.$$

and by the definition of  $F$  from (3) this is indeed equal to zero. So  $D_EC_F = C_E$ .

In the paragraph leading up to the statement of Theorem 2 we showed that  $\mathbf{LF}$  has an inverse in  $H^\infty$ . In particular,  $\mathbf{LF}$  evaluated in zero has a bounded inverse. Since  $D_E D_F = D_L D_F = \mathbf{L}(0)\mathbf{F}(0)$ , it follows that  $D_E D_F$  has a bounded inverse.

This shows that the conditions of Lemma 9 are indeed satisfied. We now verify that the formulas given there indeed give the formulas  $\begin{bmatrix} A & B \\ C & D \end{bmatrix}$  for the Bezout factor. We first re-write  $D_E D_F = D_L D_F$  as

$$-D_F^* D_F - B_F^* Q A_W W C_F^* D_F = -S^{-1/2} (I + D^* D) S^{-1/2} - S^{-1/2} B^* Q A_W C_F^* D_F,$$

and using the above established  $C_F^* D_F = -A_F^* Q B_F$  this equals

$$-S^{-1/2} (I + D^* D) S^{-1/2} + S^{-1/2} B^* Q A_W A_F^* Q B S^{-1/2} = -S^{-1/2} (I + D^* D - B^* Q A_W A_F^* Q B) S^{-1/2}.$$

We subsequently rewrite  $B_F + B_E D_F = B_F + B_L D_F$  as:

$$BS^{-1/2} - A_W W C_F^* D_F,$$

and using the above established  $C_F^* D_F = -A_F^* Q B_F$  this equals

$$BS^{-1/2} + A_W W A_F^* Q B_S^{-1/2} = (I + A_W W A_F^* Q) B_S^{-1/2}.$$

We then have for the ‘A’ operator of the Bezout factor:

$$A_L - (B_F + B_L D_F)(D_L D_F)^{-1} C_L = A_W + (I + A_W W A_F^* Q) B [I + D^* D - B^* Q A_W A_F^* Q B]^{-1} B^* Q A_W,$$

which is precisely  $\underline{A}$ . Using the above established identities, the formulas for the other state space parameters for the Bezout factor can be similarly verified.  $\square$

**Lemma 11.** *Let  $[\mathbf{G}, \mathbf{H}]$  be the transfer function of the system*

$$\left[ \begin{array}{c|cc} A & B_G & B_H \\ \hline C & D_G & D_H \end{array} \right],$$

and assume that  $D_G$  is invertible. Then

$$\left[ \begin{array}{cc|c} A - B_G D_G^{-1} C & B_H - B_G D_G^{-1} D_H & \\ \hline D_G^{-1} C & D_G^{-1} D_H & \end{array} \right],$$

is a realization of  $\mathbf{G}^{-1} \mathbf{H}$ .

*Proof.* It is easily seen that  $\mathbf{G}^{-1}$  has realization

$$\left[ \begin{array}{cc|c} A - B_G D_G^{-1} C & -B_G D_G^{-1} & \\ \hline D_G^{-1} C & D_G^{-1} & \end{array} \right].$$

This realization and the realization of  $\mathbf{H}$  satisfy the assumptions of Lemma 8 and the claimed result follows.  $\square$

**Corollary 12.** *The transfer function of  $\left[ \begin{array}{c|c} \bar{A} & \bar{B} \\ \hline \bar{C} & \bar{D} \end{array} \right]$  is a robustly stabilizing controller as claimed in Theorem 6.*

*Proof.* This follows from a application of Lemma 11 to the system  $\left[ \begin{array}{c|c} A_L & B_L \\ \hline C_L & D_L \end{array} \right]$  from (4). To verify the details it is convenient to repeat the formulas for  $\left[ \begin{array}{c|c} A_L & B_L \\ \hline C_L & D_L \end{array} \right]$ .

$$\left[ \begin{array}{c|cc} A_W & -A_W W F^* & -A_W W (C^* + F^* D^*) \\ \hline S^{-1/2} B^* Q A_W & -S^{-1/2} (I + B^* Q A_W W F^*) & -S^{-1/2} (D^* + B^* Q A_W W (C^* + F^* D^*)) \end{array} \right].$$

It then follows as mentioned above from Lemma 11 that the ‘D’ operator of the robustly stabilizing controller is given by

$$\begin{aligned} & (I + B^* Q A_W W F^*)^{-1} (D^* + B^* Q A_W W (C^* + F^* D^*)) \\ &= (I + B^* Q A_W W F^*)^{-1} B^* Q A_W W C^* + (I + B^* Q A_W W F^*)^{-1} (I + B^* Q A_W W F^*) D^* \\ &= (I + B^* Q A_W W F^*)^{-1} B^* Q A_W W C^* + D^*, \end{aligned}$$

which checks. Using this formula for  $D_G^{-1}D_H$  and Lemma 11, the ‘ $B$ ’ operator of the robustly stabilizing controller equals

$$-A_W W(C^* + F^* D^*) + A_W W F^* [D^* + (I + B^* Q A_W W F^*)^{-1} B^* Q A_W W C^*].$$

After canceling terms this equals

$$-A_W W C^* + A_W W F^* (I + B^* Q A_W W F^*)^{-1} B^* Q A_W W C^*,$$

which may be rewritten as

$$\begin{aligned} & -A_W W C^* + A_W W F^* B^* Q (I + A_W W F^* B^* Q)^{-1} A_W W C^* \\ & = -A_W W C^* + [I - (I + A_W W F^* B^* Q)^{-1}] A_W W C^* \\ & = -(I + A_W W F^* B^* Q)^{-1} A_W W C^*, \end{aligned}$$

which checks. By Lemma 11, the ‘ $A$ ’ operator of the robustly stabilizing controller equals

$$A_W - A_W W F^* (I + B^* Q A_W W F^*)^{-1} B^* Q A_W.$$

Rewriting gives that this equals

$$\begin{aligned} & [I - A_W W F^* (I + B^* Q A_W W F^*)^{-1} B^* Q] A_W \\ & = [I - (I + A_W W F^* B^* Q)^{-1} A_W W F^* B^* Q] A_W \\ & = (I + A_W W F^* B^* Q)^{-1} A_W, \end{aligned}$$

which checks. Similarly, by Lemma 11, the ‘ $C$ ’ operator of the robustly stabilizing controller equals

$$-(I + B^* Q A_W W F^*)^{-1} B^* Q A_W,$$

which checks. □

## References

- [1] Ruth F. Curtain. Robust stabilizability of normalized coprime factors: the infinite-dimensional case. *Internat. J. Control*, 51(6):1173–1190, 1990.
- [2] Ruth F. Curtain. Robustly stabilizing controllers with internal loop. In *Control of uncertain systems: modelling, approximation, and design*, volume 329 of *Lecture Notes in Control and Inform. Sci.*, pages 79–98. Springer, Berlin, 2006.
- [3] Ruth F. Curtain. Robustly stabilizing controllers with respect to left-coprime factor perturbations for infinite-dimensional linear systems. *Systems Control Lett.*, 55(7):509–517, 2006.

- [4] Ruth F. Curtain and Mark R. Opmeer. Normalized doubly coprime factorizations for infinite-dimensional linear systems. *Math. Control Signals Systems*, 18(1):1–31, 2006.
- [5] Ruth F. Curtain and Mark R. Opmeer. State space formulas for a solution of the suboptimal Nehari problem on the unit disc. *Integral Equations Operator Theory*, 64(1):35–59, 2009.
- [6] Ruth F. Curtain, George Weiss, and Martin Weiss. Stabilization of irrational transfer functions by controllers with internal loop. In *Systems, approximation, singular integral operators, and related topics (Bordeaux, 2000)*, volume 129 of *Oper. Theory Adv. Appl.*, pages 179–207. Birkhäuser, Basel, 2001.
- [7] Ruth F. Curtain and Hans Zwart. *An introduction to infinite-dimensional linear systems theory*, volume 21 of *Texts in Applied Mathematics*. Springer-Verlag, New York, 1995.
- [8] Tryphon T. Georgiou and Malcolm C. Smith. Optimal robustness in the gap metric. *IEEE Trans. Automat. Control*, 35(6):673–686, 1990.
- [9] Keith Glover and Duncan McFarlane. Robust stabilization of normalized coprime factor plant descriptions with  $H_\infty$ -bounded uncertainty. *IEEE Trans. Automat. Control*, 34(8):821–830, 1989.
- [10] Y. Inouye. Parametrization of compensators for linear systems with transfer functions of bounded type. In *Proc. CDC*, pages 2083–2088, 1988.
- [11] Kalle M. Mikkola. Coprime factorization and dynamic stabilization of transfer functions. *SIAM J. Control Optim.*, 45(6):1988–2010 (electronic), 2007.
- [12] Kalle M. Mikkola. Weakly coprime factorization and state-feedback stabilization of discrete-time systems. *Math. Control Signals Systems*, 20(4):321–350, 2008.
- [13] Job Oostveen. *Strongly stabilizable distributed parameter systems*, volume 20 of *Frontiers in Applied Mathematics*. Society for Industrial and Applied Mathematics (SIAM), Philadelphia, PA, 2000.
- [14] Mark R. Opmeer. Infinite-dimensional linear systems: a distributional approach. *Proc. London Math. Soc. (3)*, 91(3):738–760, 2005.
- [15] Mark R. Opmeer. *Model reduction for controller design for infinite-dimensional systems*. PhD thesis, University of Groningen, 2006.
- [16] Mark R. Opmeer and Ruth F. Curtain. Linear quadratic Gaussian balancing for discrete-time infinite-dimensional linear systems. *SIAM J. Control Optim.*, 43(4):1196–1221, 2004/05.

- [17] Malcolm C. Smith. On stabilization and the existence of coprime factorizations. *IEEE Trans. Automat. Control*, 34(9):1005–1007, 1989.