

Building Environment 2

Lecture 03/10/05

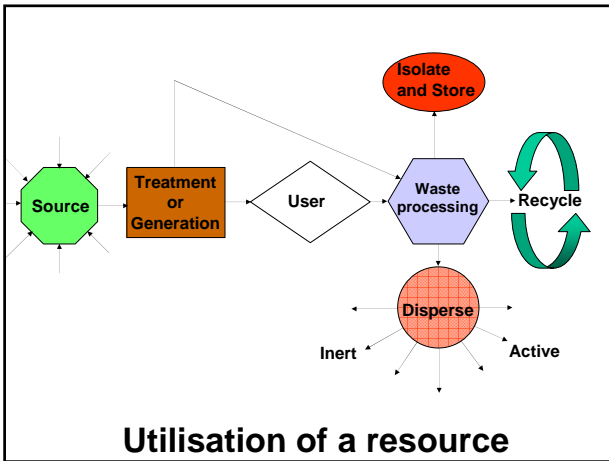
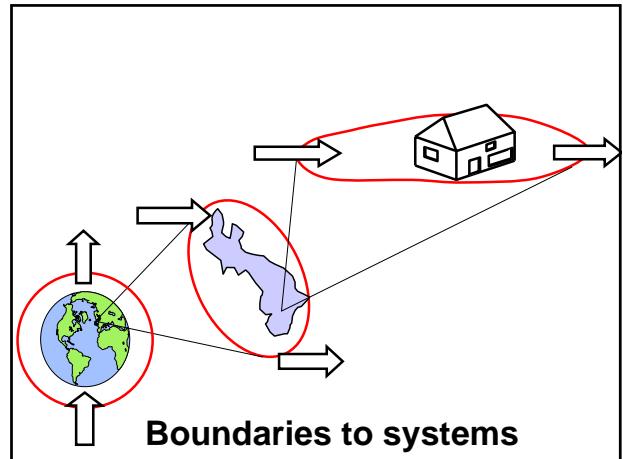

Design considerations

- Supply and demand
- Quality of Supply
- Distribution strategy
- Protection
- Maintenance
- Flexibility
- Expansion
- Costs

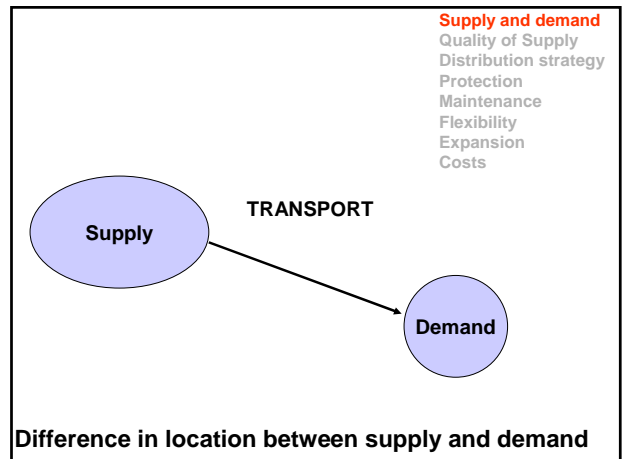
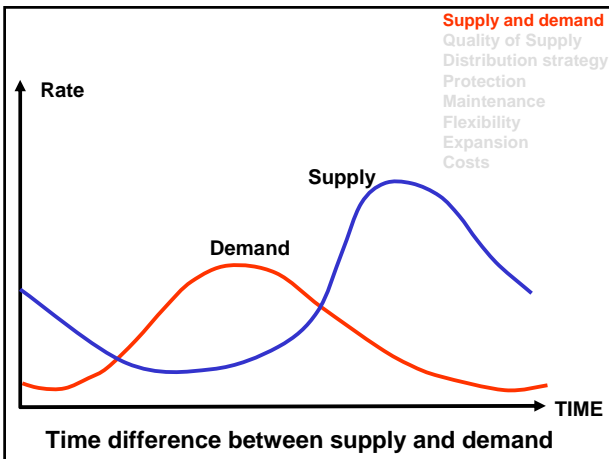

Storage of resource

- Accommodates differences in time of supply and demand
- Provides added security of supply on disruption of service
- Allows service to be provided at the average demand
- Suitable location for change in nature of supply
- May weaken control over quality of supply

Statistical nature of supply and demand

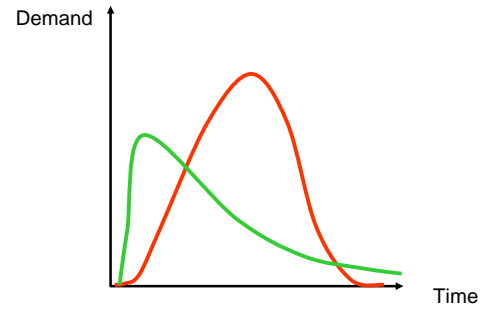

Interrupted supply

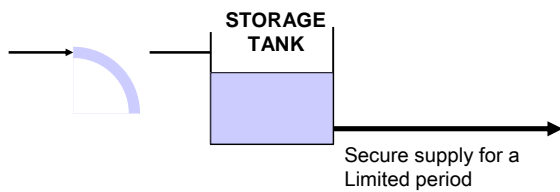

Provides added security of supply on disruption of service

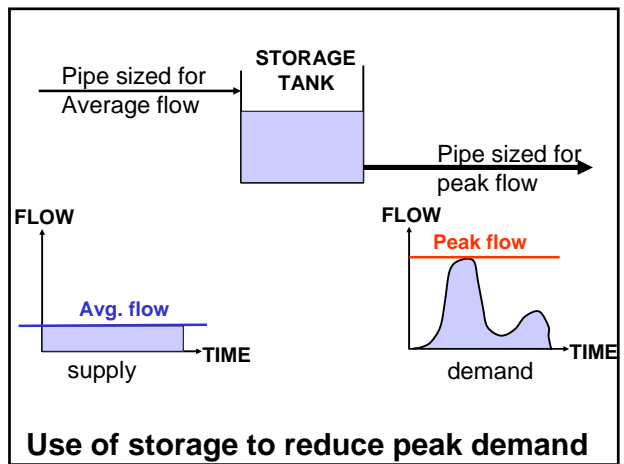

Use of storage to reduce peak demand

Additional point of access for contamination

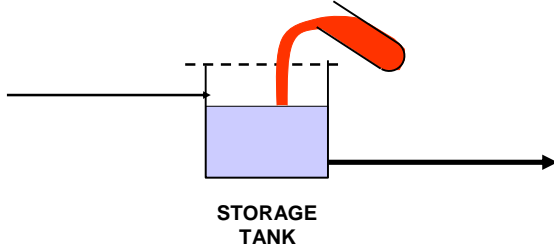

May weaken control over quality of supply

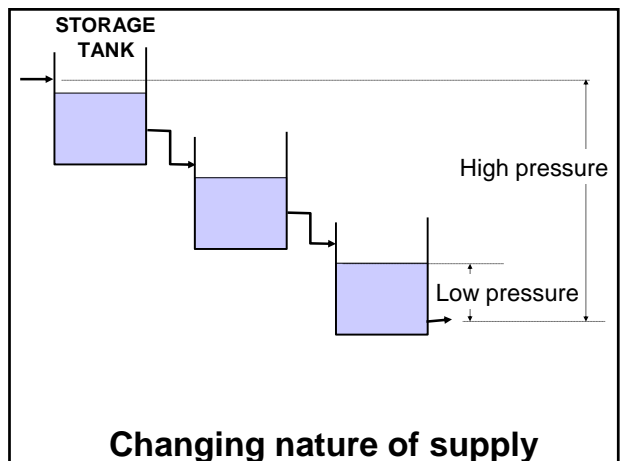

Changing nature of supply

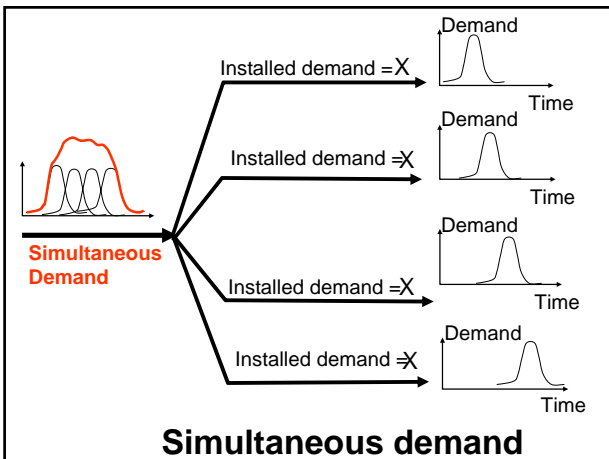
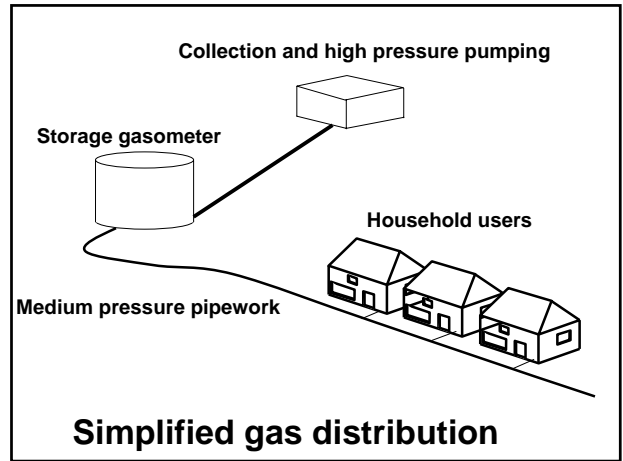
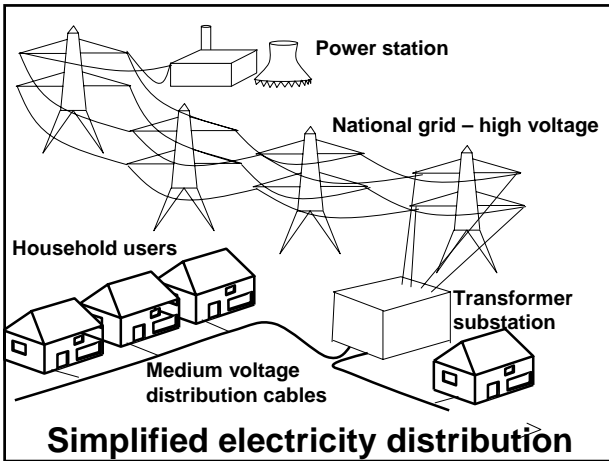

Installed demand = sum of all connected loads
 Simultaneous demand = maximum load likely at any time

Simultaneous demand = installed demand x diversity

Diversity can be estimated using statistical methods if use of a service is random. However, there are often non-random factors that affect the use of services, and under these circumstances observation of actual demand is needed.

Design considerations

Supply and demand
Quality of Supply
Distribution strategy
Protection
Maintenance
Flexibility
Expansion
Costs

Design considerations

Supply and demand
Quality of Supply
Distribution strategy
Protection
Maintenance
Flexibility
Expansion
Costs

Quality

Water:

Issues of safety:

to people: pathogens, lead, pesticides, nitrates

to system: hardness of water, acidity

Issues of acceptability

to people: clarity, colour, smell, taste

Quality

GAS

Pressure,
Smell,
Moisture content
Calorific value

Quality

Electricity

Voltage variation, maximum and minimum

Frequency

Security of supply

Building Environment 2

Lecture 10/10/05

Design considerations

Supply and demand
 Quality of Supply
 Distribution strategy
 Protection
 Maintenance
 Flexibility
 Expansion
 Costs

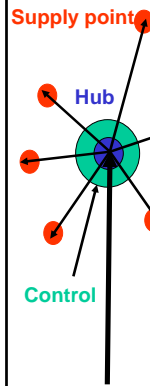

CHARACTERISTICS

1. One spoke to each supply point,
2. One control at the hub for all points,
3. Distance from hub to supply may be a limiting factor,
4. No diversity allowed on final supply,
5. Diversity allowed on feed to hub,
6. Failure of feed to hub affects all of the supply points,
7. Feed can be protected at hub.

Radial distribution



CHARACTERISTICS

1. Added security of supply because there are two paths to supply points,
2. Increased capacity of ring because of two paths to each supply point,
3. Ring vulnerable to failure if each final supply is not controlled,
4. Less control of what is connected to the ring because control is distributed.

Ring Main



CHARACTERISTICS

1. Hierarchical structure leads to close control,
2. Maximum use can be made of diversity,
3. Control must be able to discriminate different types of fault,
4. Failure of a trunk route leads to failure of distributed branches.

Tree distribution

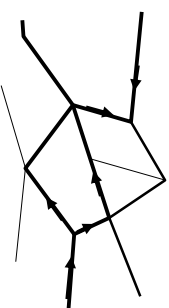

CHARACTERISTICS

1. Organic growth over time,
2. Often poorly documented,
3. Many paths gives security of supply,
4. Non-linear flow characteristics will make it difficult to forecast flows,

Network distribution

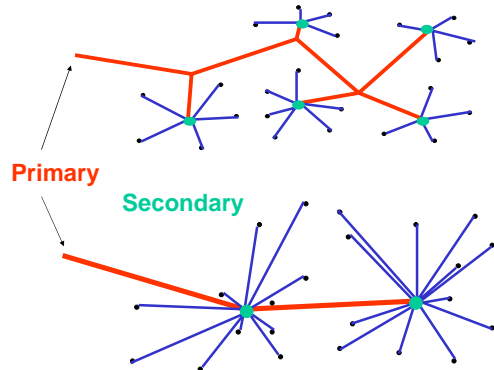

Organisation of distribution

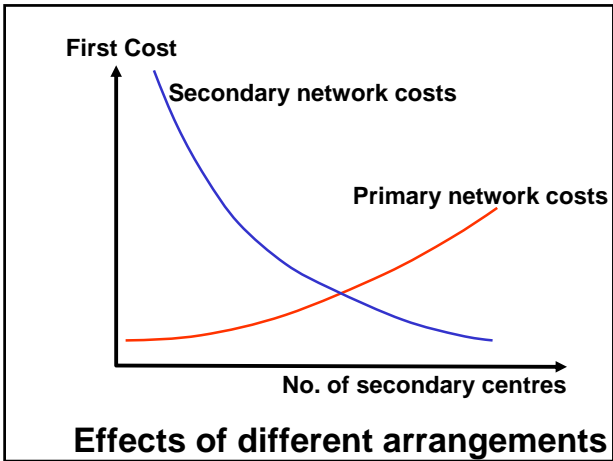

Distribution of Services within Buildings

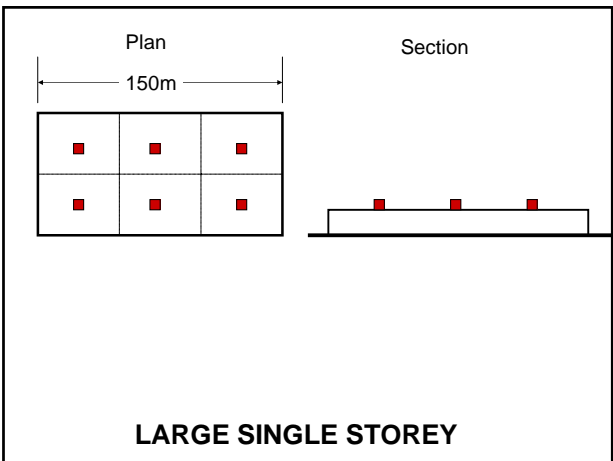
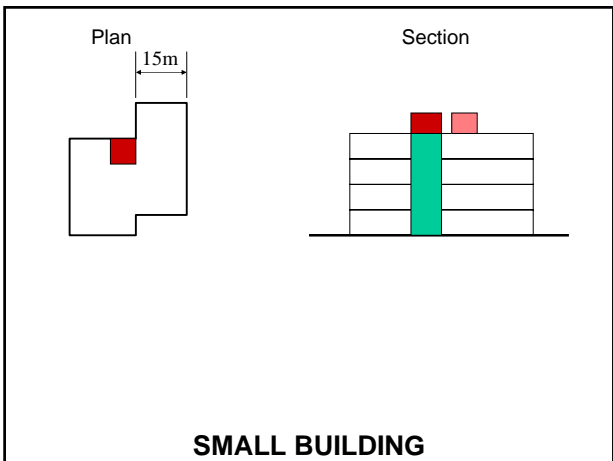
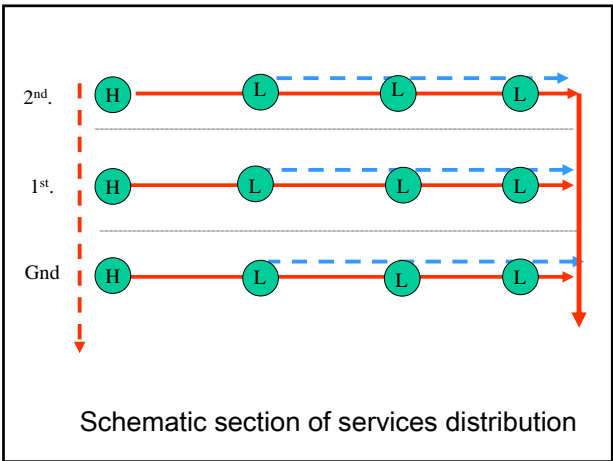
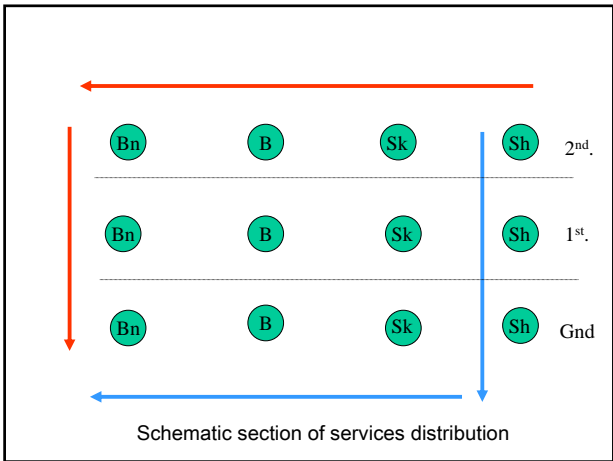

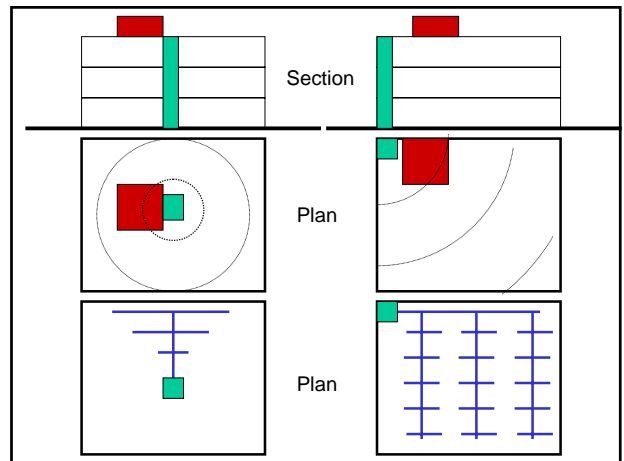
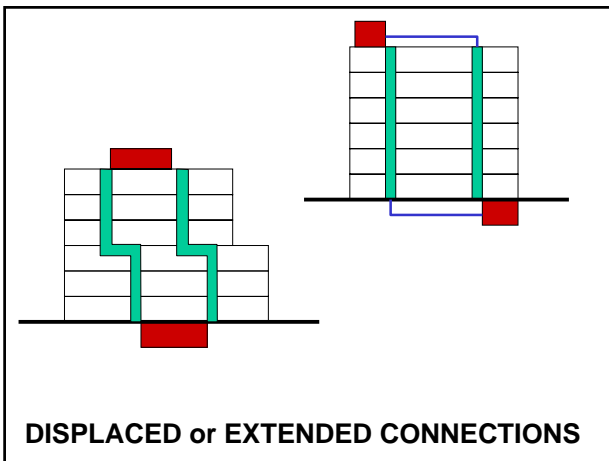
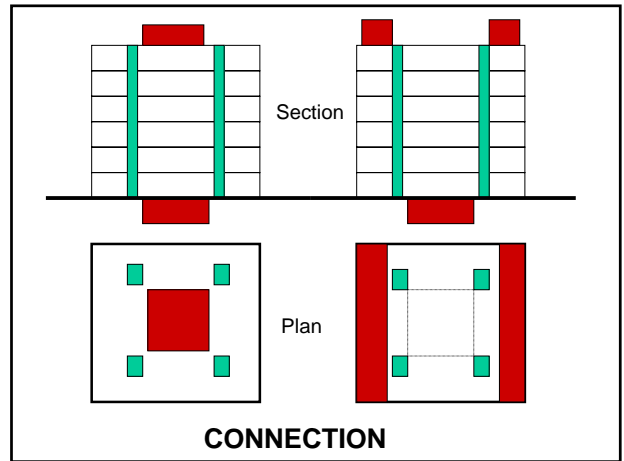
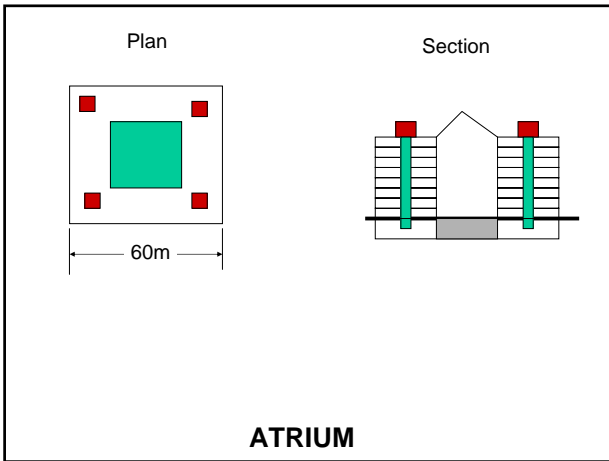
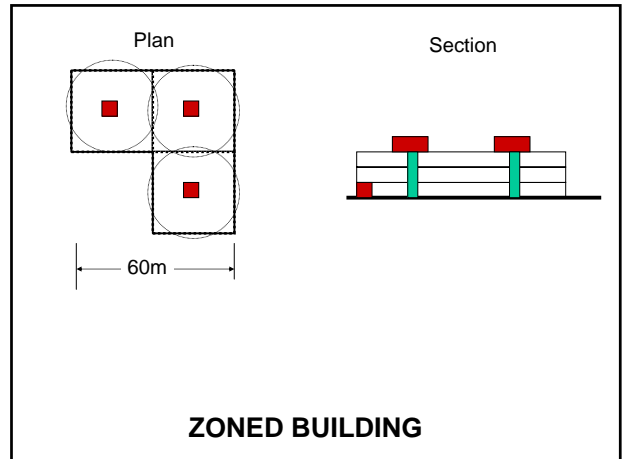
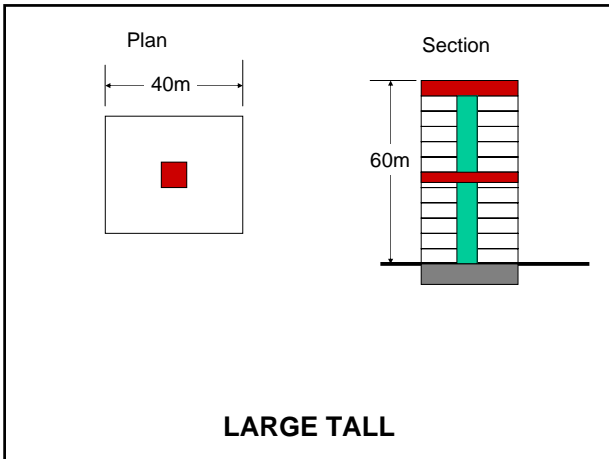

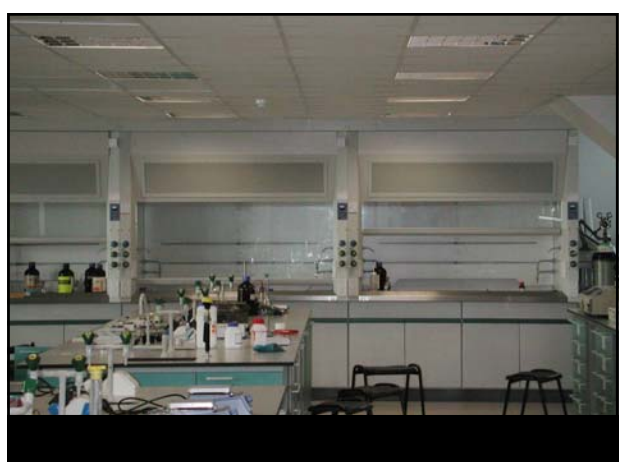

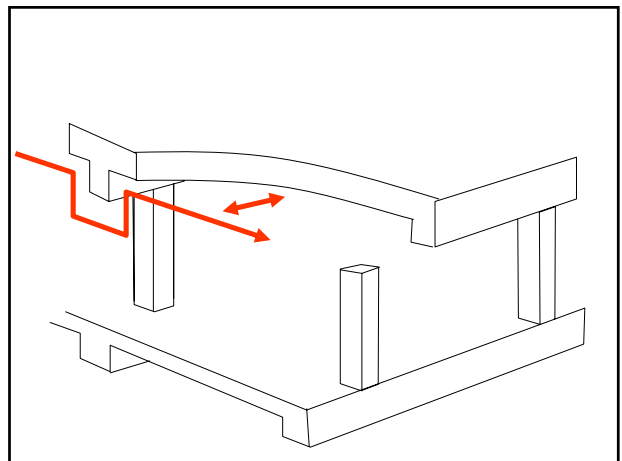
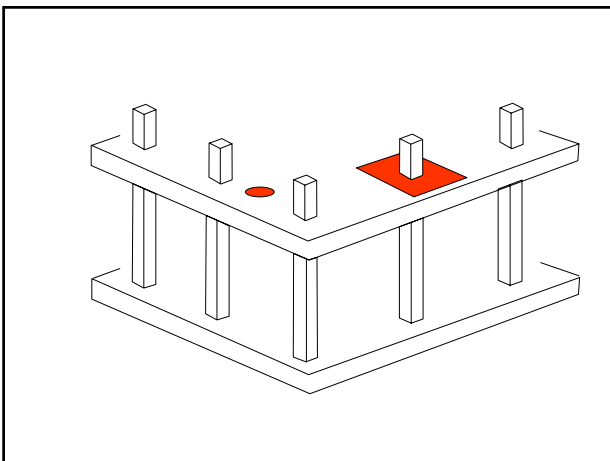
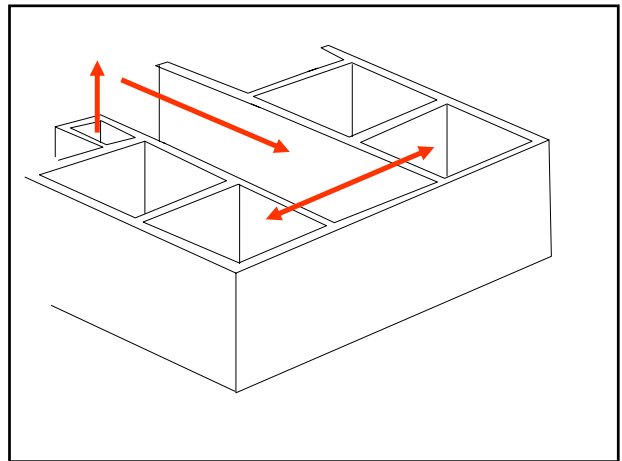
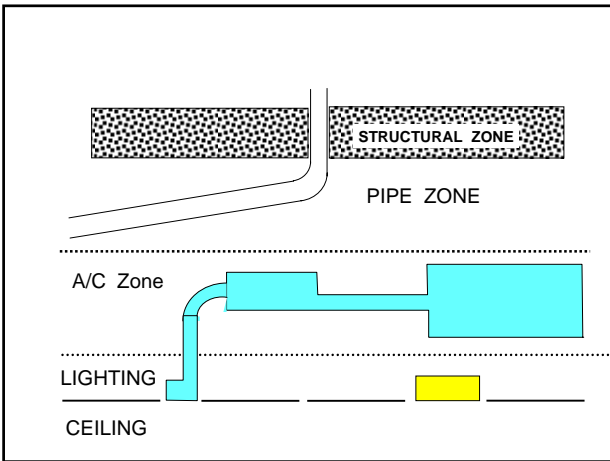
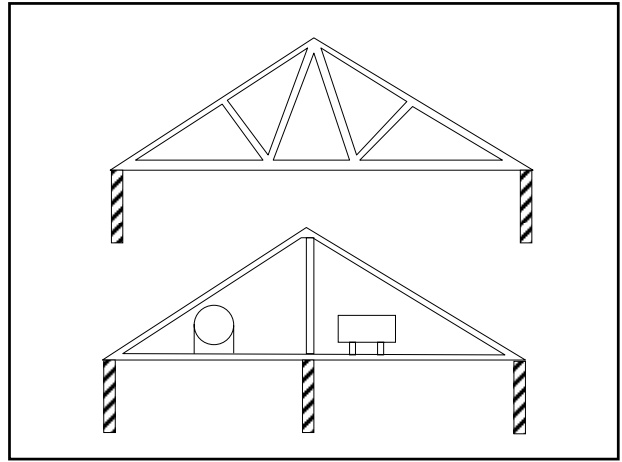



Richards Medical Research Centre

Louis I Kahn



Richards Medical Research Centre

Louis I Kahn



Salk Institute

Louis I Kahn

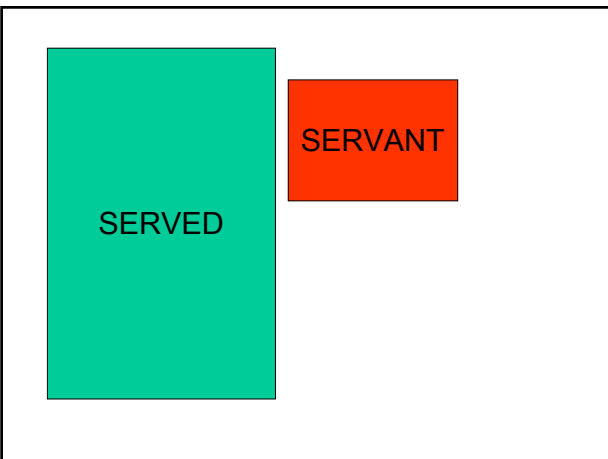
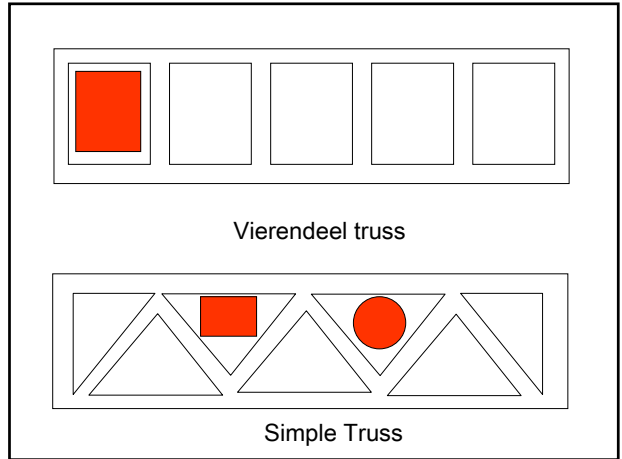

Design considerations

- Supply and demand
- Quality of Supply
- Distribution strategy
- Protection
- Maintenance
- Flexibility
- Expansion
- Costs

Protection

Users of the system and general public

System itself and its integrity

Buildings served by the system

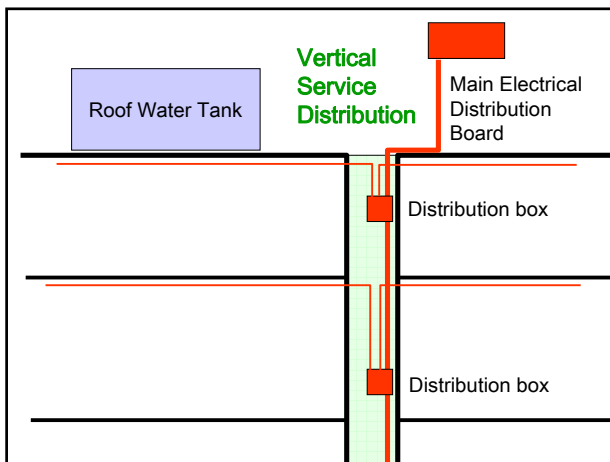
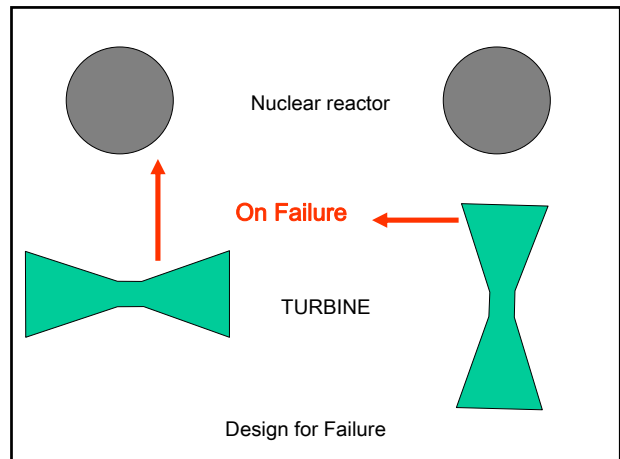

Protection against Misuse or catastrophic Failure

Example using electrical circuits

Over Load - moderately excessive load over a long period of time

Failure - extremely high currents caused by component failure

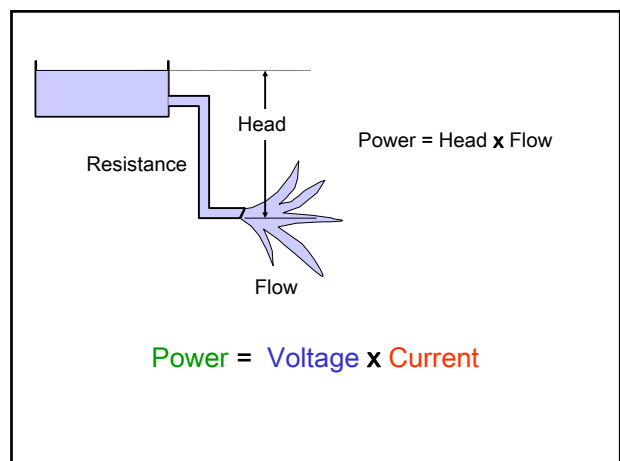
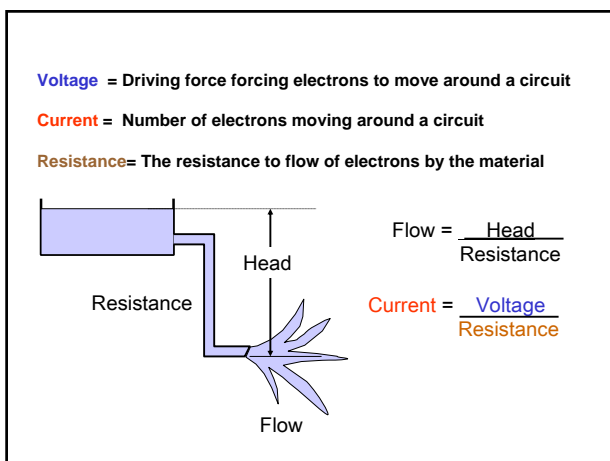

Current x Voltage = Power transmitted

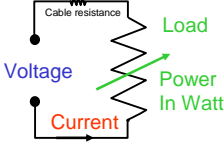
$$\text{Current} = \frac{\text{Power transmitted}}{\text{Voltage}}$$

Power loss in cable = Current x Voltage drop in cable

But,

Voltage drop in cable = Current x Resistance

And so,

Power loss in cable = Current x Current x Resistance

$$= \frac{(\text{Power transmitted})^2}{(\text{Voltage})^2} \times \text{Resistance}$$

NORMAL CURRENT

Current x Voltage = Power transmitted

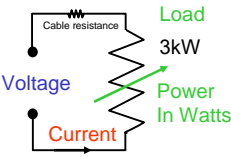
$$\text{Current} = \frac{\text{Power transmitted}}{\text{Voltage}} = \frac{3000}{240} = 12.5 \text{ amps}$$

FAULT CURRENT

Declared Voltage = 240 volts,
 maximum allowed voltage drop = 2.5%
 Maximum voltage drop = $240 \times \frac{2.5}{100} = 6 \text{ volts}$

Cable resistance = $\frac{6 \text{ volts}}{12.5 \text{ amps}} = 0.48 \text{ Ohms}$

Short Circuit current = $\frac{\text{Voltage drop}}{\text{Resistance}} = \frac{240}{0.48} = 500 \text{ amps}$

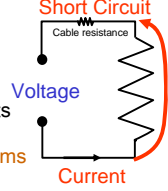
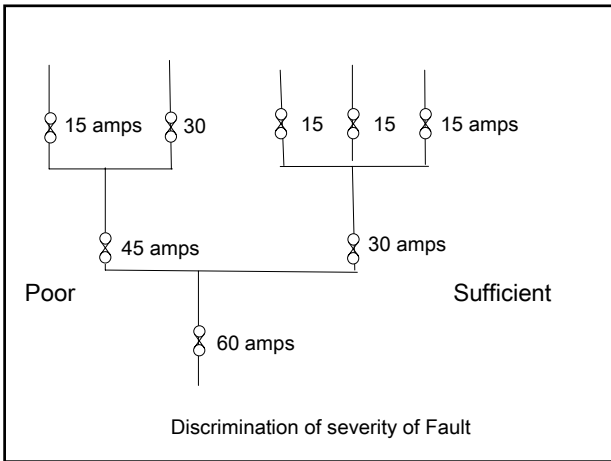
Design considerations

- Supply and demand
- Quality of Supply
- Distribution strategy
- Protection
- Maintenance
- Flexibility**
- Expansion
- Costs

Flexibility

- Flexibility versus adaptability
- Served and servant spaces
- Extension and lifetime use
- Development of industry and methods, loss of skills

